

WIRELESS TELEPHONY

Ernst Ruhmer

TRANSLATED BY

J. ERSKINE-MURRAY, D.Sc.

YC 19376

REESE LIBRARY
OF THE
UNIVERSITY OF CALIFORNIA.

Class

The D. Van Nostrand Company

intend this book to be sold to the Public
at the advertised price, and supply it to
the Trade on terms which will not allow
of reduction.

WIRELESS TELEPHONY.

WIRELESS TELEPHONY

In Theory and Practice

BY

ERNST RUHMER

TRANSLATED FROM THE GERMAN

BY

JAMES ERSKINE-MURRAY, D.Sc.

FELLOW OF THE ROYAL SOCIETY OF EDINBURGH
MEMBER OF THE INSTITUTION OF ELECTRICAL ENGINEERS

With an Appendix by the Translator

AND NUMEROUS ILLUSTRATIONS

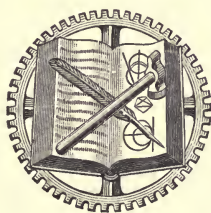

NEW YORK

D. VAN NOSTRAND COMPANY

23 MURRAY AND 27 WARREN STREETS

LONDON

CROSBY LOCKWOOD AND SON

1908

TK6550

R8

REESE

AUTHOR'S PREFACE.

THE friendly reception given by both the home and foreign technical press to my little book, "On Selenium and its Importance in Electro-technics," which appeared in the end of 1902, has encouraged me to make known to wider circles the researches and experiments which have been made in Wireless Telephony up to the present.

In order to render the presentation of the subject complete, notice has been taken of Light-Telephony, and of the fundamental physical phenomena on which it is based, especially in regard to its bearing on more recent work.

The greater part of the second section is devoted to a description of Electric Wave Telephony, the recent advances of which are of the greatest promise, and will on this account be of far-reaching interest.

In accordance with the frequently expressed wishes of my friends, a large number of references

to the literature of the subject have been given throughout the text, and in the name and subject index at the end of the book.

May this latest little book receive on its publication the same reception as has been accorded to my earlier ones.

ERNST RUHMER.

BERLIN, S.W., 48,

15th February 1907.



TRANSLATOR'S PREFACE.

WIRELESS Telephony is now as far advanced in practice as wireless telegraphy was ten years ago ; indeed, further, for in 1897 the greatest distance to which a message had been transmitted was under ten miles, while the latest record in wireless telephony is two hundred. Its theory also is much more complete than was that of the elder branch at that date. We may therefore look for a much more rapid development than has taken place in telegraphy, great as this is, and though telephony without wires presents its own peculiar difficulties, one would hardly be astonished if, within the next decade, it should provide a means of transmitting articulate speech to any quarter of the globe.

The present work is the first published attempt to give a complete and connected account of the subject. In view of this the author has avoided technicalities as far as possible, so that his book may be readable by all who take an interest in this remarkable development of electrical engineering, and in this the translator has closely followed the original. Indeed, with the exception of the division of the book into chapters and sections, and the inclusion of a few new illustrations and references, no

alteration has been made in the text. The translator is therefore only responsible for the matter contained in the Appendix, and not for any statements or opinions occurring in the body of the work.

Among other questions of immediate interest, the theory and practice of the production of persistent alternating currents of high frequency by means of the electric arc are thoroughly discussed. The exceedingly puzzling and apparently contradictory theories, of which so many have been published, are given their proper places in a general scheme, which accounts for and explains every type of discharge intermediate between the spark and the steady arc. Owing to this alone the book should be of value not only to amateurs and theorists, but to those who have charge of the design and operation of wireless telegraph and telephone stations.

The book is well up to date; the author describing experiments as late as February 1907, and the translator in the Appendix to November 1907. No apology is made for the inclusion in the latter of extracts from a memorandum by Professor Fessenden, one of the very foremost workers on the subject, and from the report of an independent telephone engineer on tests of his system, as the writer believes that to those for whom this book is chiefly intended, such matter is of more interest and value at first hand than in any form to which he might reduce it.

In conclusion, it is hoped that readers will recognise that the occasional omission of the actual dimensions of apparatus is, as a rule, due to the fact

that in consideration of the present chaotic situation as regards wireless patents, it would in many cases be unfair to inventors to publish numerical details which might prove essential to the proper operation of their instruments, but which are in no way necessary to an explanation of their principles and action.

J. ERSKINE-MURRAY.

34 NORFOLK STREET, LONDON, W.C.,
5th December 1907.

CONTENTS.

PART I.

WIRELESS TELEPHONY BY MEANS OF LIGHT OR HEAT RADIATIONS (RADIOPHONY).

CHAPTER I.

	PAGE
THE PHOTOPHONE - - - - -	3

CHAPTER II.

VARYING SOURCES OF RADIATION - - - - -	14
--	----

CHAPTER III.

THE SPEAKING ARC - - - - -	20
----------------------------	----

CHAPTER IV.

THE PHOTOGRAPHOPHONE - - - - -	36
--------------------------------	----

CHAPTER V.

LIGHT-TELEPHONY AT USEFUL DISTANCES -	43
---------------------------------------	----

CHAPTER VI.

BEST WORKING CONDITIONS FOR LIGHT-TELEPHONY -	72
---	----

PART II.

*WIRELESS TELEPHONY BY MEANS OF
ELECTRICAL FORCES.*

CHAPTER VII.

	PAGE
CLOSED CIRCUIT TELEPHONY - - - -	79

CHAPTER VIII.

ELECTRO-MAGNETIC INDUCTION TELEPHONY - -	88
--	----

CHAPTER IX.

SPARK TELEPHONY - - - -	96
-------------------------	----

CHAPTER X.

ACCELERATED SPARK RATES - - - -	107
---------------------------------	-----

CHAPTER XI.

MULTIPHASE SPARK DISCHARGES - - - -	118
-------------------------------------	-----

CHAPTER XII.

HIGH FREQUENCY ALTERNATORS - - - -	131
------------------------------------	-----

CHAPTER XIII.

THE ARC AS HIGH FREQUENCY GENERATOR - -	142
---	-----

CHAPTER XIV.

THE POULSEN GENERATOR - - - -	154
-------------------------------	-----

CONTENTS. xiii

CHAPTER XV.

	PAGE
MULTIPLE ARCS IN AIR - - - - -	159

CHAPTER XVI.

APPLICATIONS OF THE ARC TO TELEPHONY - -	166
--	-----

CHAPTER XVII.

THE DUDELL PHENOMENON - - - - -	174
---------------------------------	-----

CHAPTER XVIII.

FORCED VIBRATIONS - - - - -	183
-----------------------------	-----

CHAPTER XIX.

CONCLUSION - - - - -	196
----------------------	-----

APPENDIX—RECENT ADVANCES - - - - -	198
------------------------------------	-----

BIBLIOGRAPHY - - - - -	215
------------------------	-----

INDEX OF NAMES - - - - -	219
--------------------------	-----

INDEX OF SUBJECTS - - - - -	221
-----------------------------	-----



WIRELESS TELEPHONY.

INTRODUCTION.

THE term "Wireless Telephony" means, in general, the transmission of human speech to great distances without the use of a connecting wire between the sending and receiving stations.

In the simplest case the air serves as carrier of the sound waves, while the voice of the speaker is the transmitter, and the ear of the hearer the receiver.

This kind of transmission is so usual to us that we are hardly accustomed to look upon it as wireless telephony, although, with this simplest of all systems, particularly when aided by such well-known instruments as the speaking trumpet, much greater distances have been bridged than by many more complicated methods.* How astonishingly well the ordinary method may work under certain conditions is shown by the "whispering galleries" in churches, and by similar phenomena. Still better results may be obtained by employing the air as a transmitter of sound waves if we use as sender and receiver instruments which magnify, by electrical means, the volume of sound transmitted and received.

By using parabolic mirrors of 90 cm. aperture, in the focus of one of which a loud-speaking telephone acted as sender, while a sensitive microphone, connected in usual

* See "Short's Gouraudphon," *Mechaniker*, viii., p. 261, 1900, and ix., p. 79, 1901.

fashion with battery and telephone, served the purpose of receiver in the other, the author has obtained satisfactory results in calm air at distances of over 1,500 metres.

Attempts have also been made to utilise the conductivity of solids and liquids for sound, of which we may mention the use of water as the medium of propagation by Trowbridge, and its many practical applications to submarine signalling (Elisha Gray and A. J. Munday).

The methods by which speech may be transmitted by means of light and heat radiations are much more complicated ; they may be called

RADIOPHONY.

The thermophone, Bell's photophone, and light telephony, with which we shall presently deal, belong to this class.

We are, however, accustomed to think of wireless transmission as a purely electrical action.

The remarkable strides which have been made in the knowledge of magneto-electric and electro-magnetic phenomena have opened up to us many ways by which speech may be transmitted through the ether without the assistance of acoustical or optical aids.

WIRELESS TELEPHONY BY MEANS OF ELECTRICAL FORCES.

One can distinguish in this connection, as in wireless telegraphy, between various groups of methods, such as—

1. **Hydro-Telephony**, in which the transmission takes place by means of electric currents through the earth or sea.
2. **Induction - Telephony**, which employs electro-magnetic induction.
3. **Wave-Telephony**, in which electrical waves serve to carry the speech as light waves do in light-telephony.

Let us now turn to the consideration of the individual systems.

PART I.

WIRELESS TELEPHONY BY MEANS OF LIGHT OR HEAT RADIATIONS.

CHAPTER I.

THE PHOTOPHONE.

THE methods belonging to this group depend on the alteration of the intensity of the light or heat radiations sent out by the transmitting station (Photophony or Thermophony). These variations of intensity are again converted into sound waves at the receiving station. The conversion may be effected electrically by utilisation of the sensibility of selenium to light—a discovery made by May, one of Willoughby-Smith's assistants. The element selenium, which belongs to the sulphur group, exists in several modifications, but of these only the crystalline, which may be obtained from the others by heating or melting, is a conductor of electricity, and possesses the peculiarity that its conductivity varies with the illumination. In proper circumstances this form of selenium conducts the electric current many times better when illuminated than when in the dark.

The Linkage of Light and Electricity.—Smith described this discovery of May's very graphically in a letter of 12th February 1873 to Latimer Clark, at that time President of the English Institution of Telegraph Engineers, in which he said :—

“With the assistance of the microphone one can hear the footsteps of a fly as loudly as if it were the trampling of a horse on a wooden bridge, but it strikes me as much more wonderful that by means of a telephone I can hear a ray of light falling on a metal plate.”

On account of the high resistance of the preparation of selenium, and hence the difficulty of experimenting, and also in order to take the greatest possible advantage of the influence of the light, the so-called selenium cell described by Werner Siemens in 1875 is used. We shall not go into the details of its construction here.*

The Photophone.—Bell, the ingenious inventor of the telephone, was the first who achieved, after much study of the remarkable behaviour of selenium under the influence of light, and many laborious researches, the production of useful selenium cells, and, in common with Sumner Tainter, made the first practical application of the sensibility of selenium to light in combination with his telephone, by constructing a photophonic receiver (1878).†

The flat selenium cells made by Bell for this purpose consisted of two copper or brass plates, in which a large number of holes were bored, and which were separated by an insulating plate of mica. In the holes in one plate were fixed conical brass studs which entered the holes in the other plate, but without touching the plate itself.

The annular spaces surrounding the studs were filled in with melted, black, glassy selenium, and the cell heated over a gas flame until the selenium began to melt and turn into the slate-coloured crystalline modification.

Bell and Tainter also constructed cylindrical cells for use in parabolic mirrors out of a series of brass and mica discs piled alternately on one another. As the mica discs

* For further descriptions see Ernst Ruhmer, “Das Selen,” Berlin, 1902, and *E.T.Z.*, 25, pp. 1021-1030, 1904, Lecture before the Elektrotechnischen Verein, 22nd March 1904.

† See Alexander Graham Bell, “The Photophone.”

were cut of less diameter than the brass, there remained, beyond their edges, a number of ring-shaped notches into which the melted selenium was run. Each ring of selenium was thus in contact with two neighbouring brass plates. In order to keep the resistance as low as possible, all the even numbered brass plates were connected to one terminal of the cell, and all the odd to the other. Thus the selenium rings were all in parallel, and after their conversion into the grey modification, the cell offered a comparatively small resistance to the electric current.

While in the case of the flat cell, described above, the portion of the surface actually exposed to the action of light was only about 0.11 of the whole, in this newer form the ratio was as much as 0.6.

The resistance of Bell's cell was approximately 1,200 ohms when in darkness, and 600 ohms when illuminated.

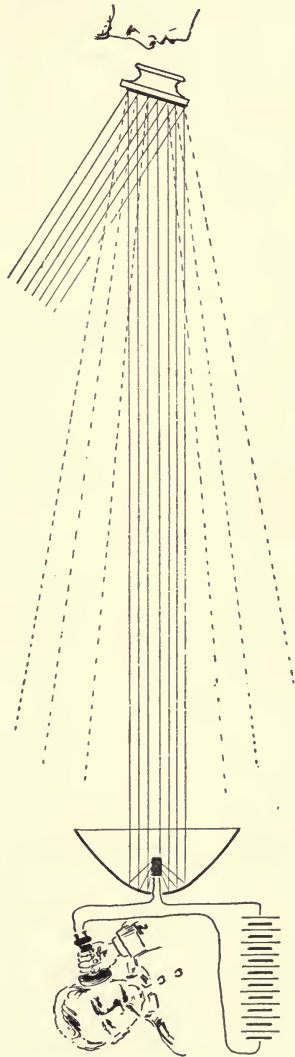

FIG. 1.
Bell's Original Photophone.

In order to reproduce the words spoken at the sending station by means of this type of cell in connection with a telephone, it was necessary to construct a transmitting apparatus which should be influenced by the waves of sound so that a ray of light directed by it on to the receiver should be made to vibrate synchronously with these waves.

Bell and Tainter have given nearly fifty different methods by which a beam of light may be thus controlled.

These methods may be divided into two groups. In one of these a source of light of constant intensity is employed, and the ray of light from it is modified at some

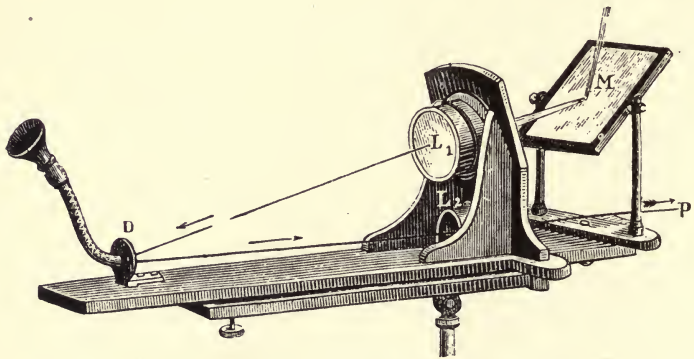

FIG. 2.

Photophonic Transmitter with Condensing Lens.

point on its way; in the other group a source of light is used in which the intensity is altered directly by the sound waves.

In the original photophone, which belonged to the first group, the rays of the sun were reflected by a mirror on to a silvered glass or mica membrane placed over a conical mouthpiece, and thence to the receiving station (Fig. 1). Since the membrane, when set in motion by the sound waves, became alternately concave and convex, the parallel rays of sunshine became alternately convergent and divergent, and thus fell upon the reflector at the receiving

station with rapidly varying intensity. These rays are concentrated at the focus of the reflector, on the selenium

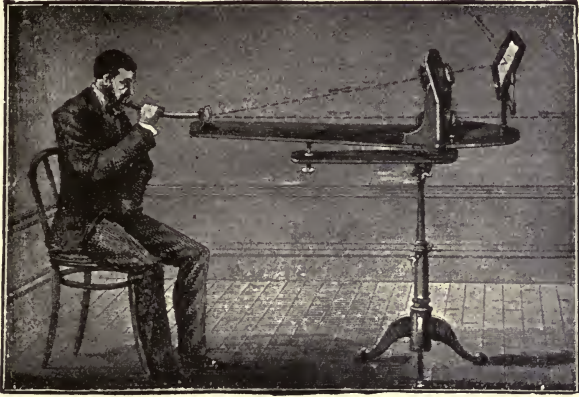

FIGS. 3 and 4.
Photophonic Transmitting and Receiving.

cell, and, if the latter be connected in series with a battery and telephone, are reconverted into sound waves.

Another arrangement, used by Bell in his experiments (Fig. 2), differs only from that shown in Fig. 1 in the addition of two lenses; the upper one, L_1 , serves to concentrate the light on the reflecting membrane, while the lower one, L_2 , renders it again parallel. Figs. 3 and 4 show the sending and receiving stations in action.

With this apparatus Bell and Tainter made a great number of experiments in which the sender and receiver were so far apart that the sound could not be heard directly through the air.

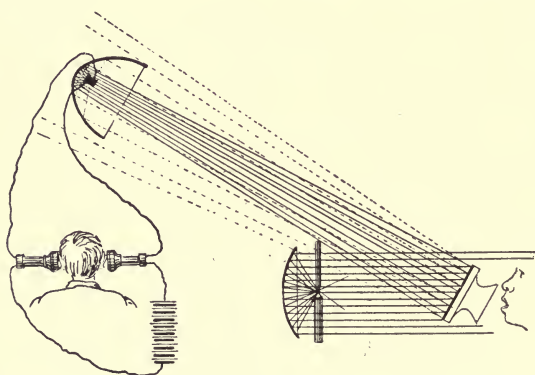

FIG. 5.
Arc Lamp as Source of Light.

In one of these experiments (1880) Tainter was at the sending station, which was placed on the tower of the Franklin College at Washington, while the receiver was in Bell's laboratory window in 1325 L Street; the distance being 213 metres. As Bell put the telephone of the receiver to his ear he heard clearly the words, "Mr Bell, if you can understand what I am saying, come to the window and wave your hat." The transmission of speech by means of light rays was thus perfect at this short distance.

Instead of the sun's rays the light of an arc lamp, rendered parallel by means of a mirror or lens, may of course be used (Fig. 5).

To the same group of transmitters belong the methods in which the ray of light is influenced by a lens with a variable focal length, or in which it is polarised and then altered in the ways discovered by Faraday and Kerr.

In Fig. 6 an arrangement of this kind is shown. The microphone *M* is in series with the battery *B* and the coil *S*. The light rays from the source *L* are rendered parallel by a lens and polarised by the Nicol's prism *P*₁. After traversing the bobbin the light is extinguished by a second crossed Nicol at *P*₂. If oscillating currents are now produced in the coil by speaking into the microphone *M*, the plane of polarisation will be more or less turned, and thus a greater or less amount of light will pass out through *P*₂, and in this way the vibrations of the membrane of the microphone may be converted into alterations of the intensity of light.

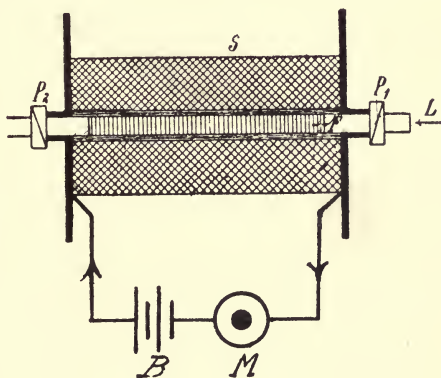

FIG. 6.

Polarised Light Transmitter controlled by Electro-magnetic Action on Plane of Polarisation.

In order to strengthen the action an iron core may be introduced into the coil having a hole bored along its axis. In this is placed a piece of transparent heavy glass which possesses a large magneto-optic constant. This method differs from the above-described system in that it is possible to arrange that practically no light passes out to the receiving station when the apparatus is at rest.

There are many other ingenious methods belonging to the first group, which might be described here, but which we shall, however, pass over as they do not introduce any new principle of importance in wireless telephony.

Before we go on to the methods of the second group, which employ a source of light whose intensity varies with the sound waves, we shall describe shortly an arrangement of Bell's in which the transmission is by means of the heat waves which accompany the light.

Bell's Thermophone.—On the occasion of the exhibition at Chicago in 1893, Bell showed a thermophonic apparatus of this type for the transmission of speech (Figs. 7-9).

The transmitter is, as in the photophone, a thin silvered

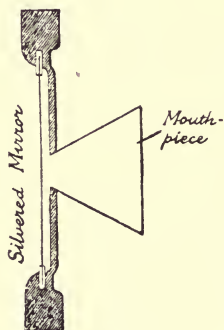

FIG. 7.

Photophonic Transmitter.

mirror against a mouthpiece, which reflects the light of an arc lamp.

The receiver (Fig. 9) consists of a small glass bulb, containing a little blackened (charred) piece of cork. From the bulb rubber tubes are carried to the ears of the observer. The cork ball is placed in the focus of the parabolic mirror of the receiver. The variations in the intensity of the heat radiations cause, as Bell has shown, corresponding alterations in the volume of the cork, and therefore in the surrounding air, which of course travel through the tubes as sound waves.

Mercadier's radiophone is almost identical with this arrangement of Bell's, differing from it only slightly as to the construction of the thermophonic receiver. This latter

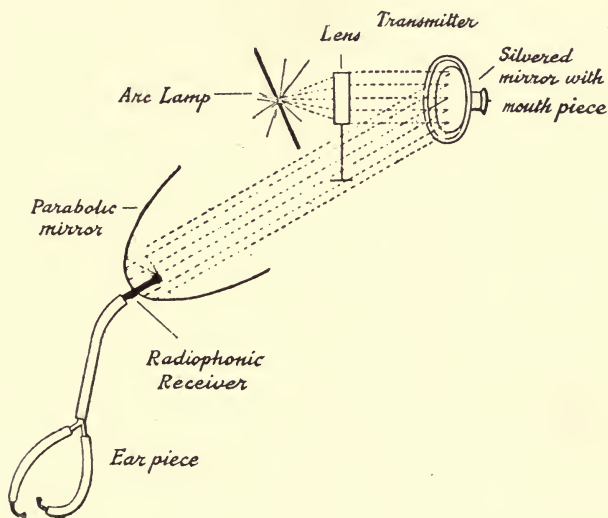

FIG. 8.
Thermotelephone.

consists of a glass tube with thin walls, closed at one end and containing a plate of mica covered with lampblack.

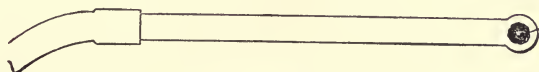

FIG. 9.
Thermophonic Tube.

To the open end of the tube rubber connecting tubes are attached as before.

The mica gives out sound waves corresponding to the variations of intensity of the light from the transmitter just as in Bell's form.

Another thermophonic receiver, in which the reception is telephonic, is shown in Fig. 10. It consists of a thin-walled hollow sphere of iron B, forming one pole of a magnet D, on which is a coil of wire in series with the telephone E. The undulating rays of heat, striking on the pole B, cause corresponding variations in the strength of the magnet, and hence produce induction currents in the coil C which are audible in the telephone. A similar result may be obtained by means of a thermopile.

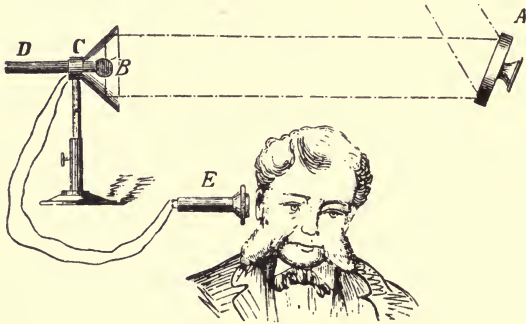

FIG. 10.
Thermophone in Use.

The loudness of the thermophone is as a rule much less than that of the photophone, in which a selenium cell is used; the simple thermophonic receivers which we have described standing in something of the same relation to the selenium cell as a telephonic transmitter does to the microphone, *i.e.*, the first converts the energy actually transmitted into sound waves, while the latter merely controls a new source of power.

The apparatus of Bell's which we have described above was found capable, at the Chicago Exhibition, of transmitting speech to a distance of about 100 metres. We may here remark that Tainter, being struck with the extraordinary sensibility of blackened surfaces, attempted



to substitute soot for selenium in the selenium cell. One of these receivers, a so-called soot cell, was then connected in series with a telephone and battery as in the case of a selenium cell. It is not known whether practical results were obtained with this altered form of thermophonic receiver.

CHAPTER II.

VARYING SOURCES OF RADIATION.

Varying Source of Light. — Let us now turn to the second class of radiophonic transmitters, which employ a source of light which varies with the sound waves. The simplest example of this kind is one in which a König's manometric flame is used.

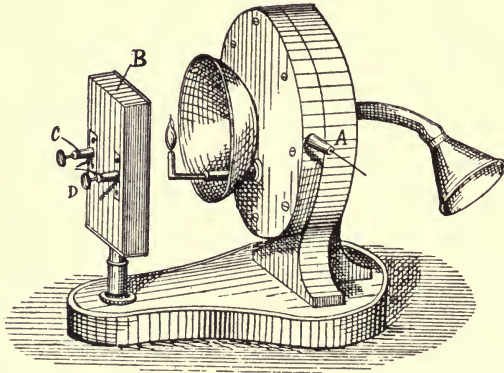

FIG. II.

Jamieson's Transmission by Manometric Flame.

It is not certain to whom the credit of having first used such a flame for radiophonic purposes should be awarded. It is very probable that Bell's photophonic experiments may have suggested the same idea to several minds at once.

Apparently one of the first publications was made by Andrew Jamieson, of Glasgow (*Nature*, 10, 11, 1881), from whose description J. W. Giltay in Delft constructed the

photophone shown in Fig. 11. This consisted of a manometric capsule A as transmitter and a selenium cell B as receiver. Since the little 1.5 cm. high flame did not give off sufficient light, Giltay improved it by drawing it through a wash-bottle containing gasoline (Fig. 12). If one speaks into the mouthpiece the membrane in the manometric capsule vibrates, the gas in the capsule is compressed or rarified in accordance with the sound waves, which causes the flame to rise and fall with a rapidity too great to be detected by the naked eye. These alterations of the intensity of illumination act on the selenium cell, and give in the telephone connected to it a perfect reproduction of the original voice.

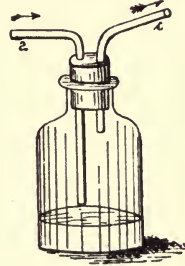

FIG. 12.
Gasoline Bottle.

In order to show that the transmission is really due to

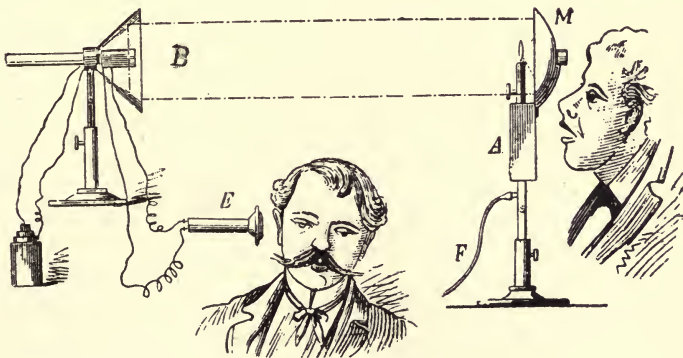

FIG. 13.
Varying-flame Photophone.

the action of the light on the selenium cell one may introduce a piece of tin or other opaque material between the flame and the cell, and notice that the reproduction of the speech entirely ceases.

Fig. 13 shows a similar radiophonic apparatus with a thermopile as receiver.

Giltay and the author afterwards employed acetylene gas instead of ordinary gas in order to obtain a flame richer in carbon.

Fig. 14 shows Giltay's original apparatus, which has, however, been recently improved by use of three acetylene flames in place of one (Fig. 15). The acetylene gas was made in a small producer *d*, like those which are used in

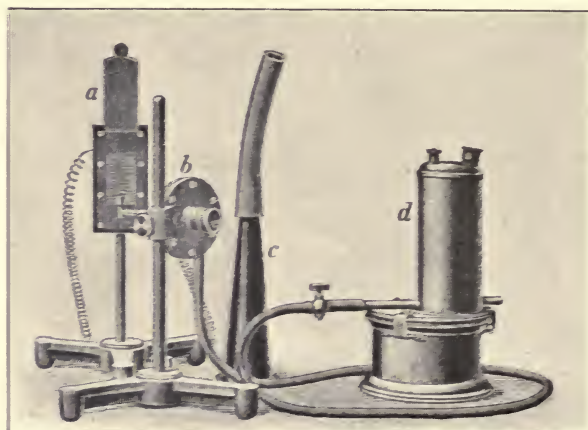

FIG. 14.
Giltay's Acetylene Flame Photophone.

cycle lamps, the water supply to the producer being regulated so that the flame, or flames, maintained a height of about 1.5 cm. The manometric capsule was so placed that the flame was about 1 cm. from the selenium cell.

Fig. 16 shows an apparatus constructed for use in schools and colleges. In this apparatus the flat selenium cell is illuminated both directly by the acetylene flame and by reflection from the spherical mirror placed behind it. The selenium cell is connected, by means of the terminals

on the lower board, with a small battery of dry cells or accumulators in series with a pair of telephones.

Of course if the two experimenters are close together, it is impossible to distinguish whether the transmission is direct or through the apparatus; it is best, therefore, to provide a long connecting wire to the telephone so that the latter may be taken into an adjoining room where the voice of the speaker is not distinctly audible.



FIG. 15.
Triple Burner Transmitter.

In order to adapt this apparatus to wireless telephony over short distances the selenium cell may be taken out of its holder, and a parabolic mirror substituted for it. This apparatus now becomes a transmitter, as shown in Fig. 17. The light of the acetylene flame is thrown by the mirror on to the receiver, which is fitted with a lens or mirror to concentrate the rays on the selenium cell, which has now been removed to some little distance and connected, as

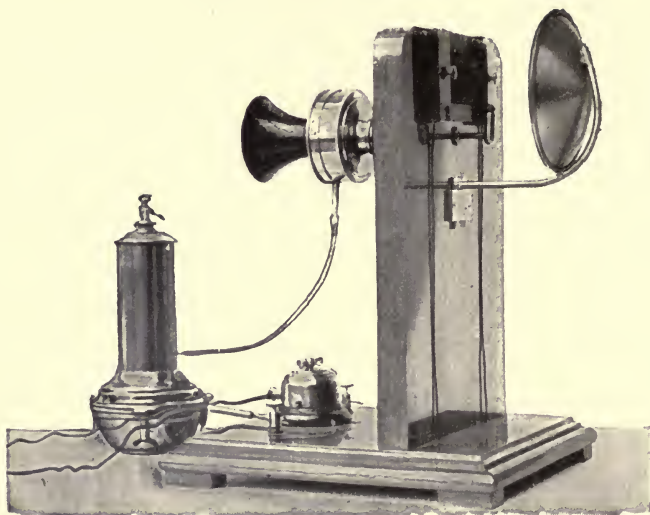
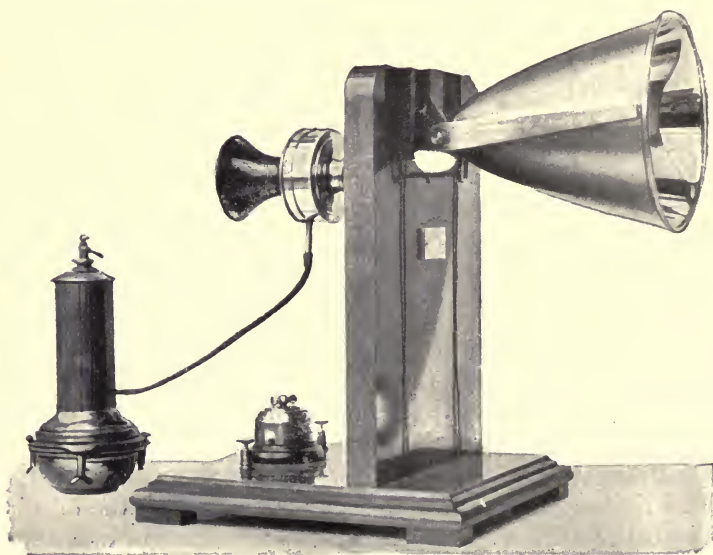

FIG. 16.

FIG. 17.
Experimental Photophones.

before, to a battery and telephone. Speech may thus be transmitted across a lecture room. (See Figs. 18 and 19.)

In place of speaking directly into the manometric capsule one may arrange this telephonically, as was first done by Giltay (Fig. 20).

In order to bridge over greater distances a more powerful, and at the same time more concentrated, source of light than a gas flame is required. Obviously the electric arc would be extremely suitable since its rays may be directed in a beam of great intensity by means of a reflector. At the time of Bell's photophone experiments, however, no way was known by which the intensity of the arc could be influenced by the vibrations of speech.

Since the attempt to transmit human speech to a distance by means of a ray of light in these radiophonic experiments had attained so little practical success, they soon fell—in spite of the ingenuity of Bell's telephone, which pursued its conquering course throughout the entire world and is now a necessary adjunct of modern civilisation—into the realms of oblivion.

CHAPTER III.

THE SPEAKING ARC.

Discovery of the Speaking Arc.—The discovery of the speaking arc by Simon in 1898 introduced new possibilities in the development of this method of wireless telephony. It is interesting in this connection to recall a paragraph (quoted by Giltay, *Mechaniker*, xi., p. 31, 1903) in the journal *Engineering* of 5th November 1880, in which the principle of the speaking arc and of its application to light-telephony was perfectly clearly given. The paragraph read: "It would be highly interesting if future research should lead to the discovery of a means of varying the intensity of the electric arc proportionately to the sonorous vibrations constituting articulate speech, so that a telephone, in circuit with a photopile exposed to its rays, would reproduce the sound by which the light was in the first instance thrown into vibration."

Let us turn now to the astonishing discovery of the talking arc, made by Simon at the Physical Institute of the University of Erlangen in the end of 1897—the discovery that an electric arc may be made to serve as a telephonic receiver. He observed that the arc of a continuous current lamp gives out a loud rattling noise if its leads run near a circuit in which a rapidly interrupted current is flowing. The latter may be produced by means of a few secondary cells connected to the interrupter of an induction coil. The oscillatory secondary currents induced in the leads of the arc lamp superpose themselves on the continuous current and produce the remarkable acoustic

phenomena. Since the action was produced by extremely small induced currents, Simon tried to cause the arc to

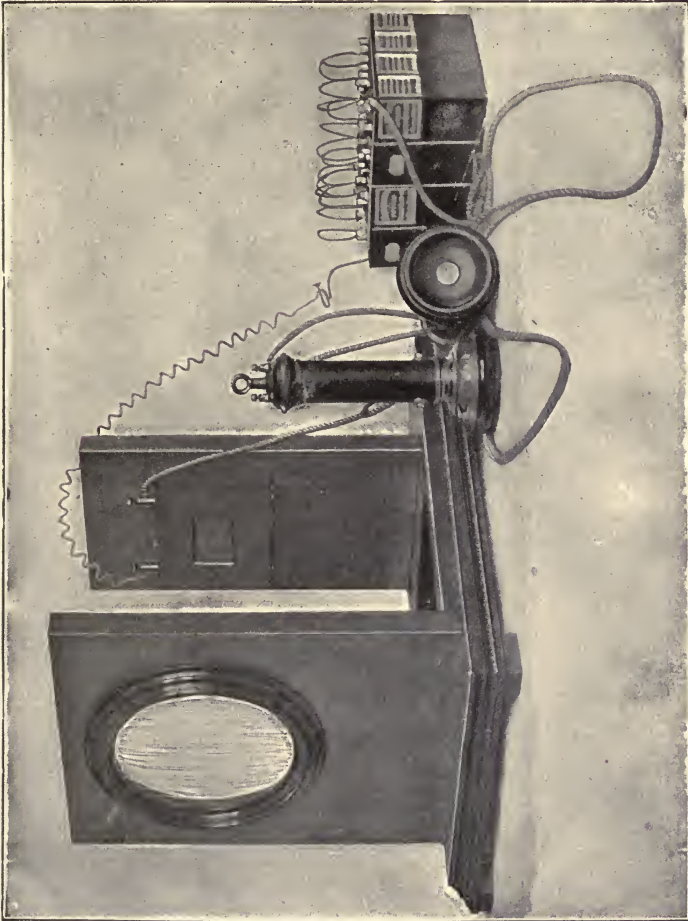

FIG. 18.—Selenium Receiver with Condensing Lens.

speak by utilising the small alternating currents produced by a microphone when it is spoken into. The arrangement used is shown in Fig. 21.

In order to intensify the effect the secondary winding of a transformer was introduced into the lamp circuit, while the primary winding conducted the oscillating currents from the microphone. The wonderful result was obtained that the arc would transmit whistling, clapping, singing, or music perfectly, and that even words spoken into the microphone were clearly repeated. The effects produced, however, were comparatively weak. Later on, as the result of experiments, it was found possible to make the action much more powerful, so that the whistling or talking of the

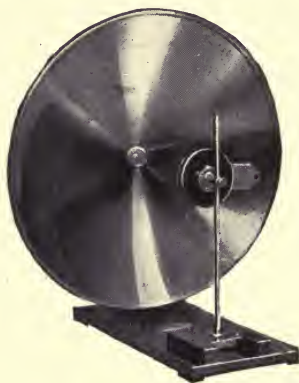

FIG. 19.—Selenium Cell with Mirror Condenser.

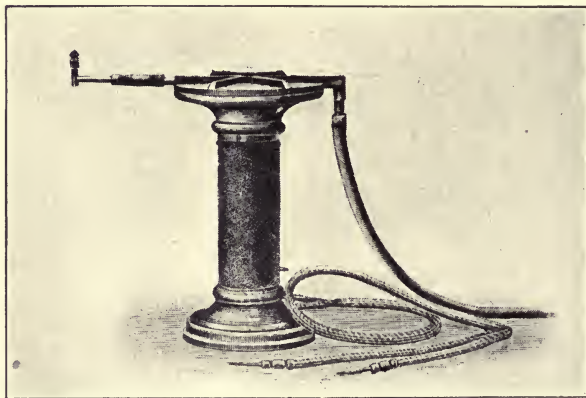

FIG. 20.

Gi. tay's Transmitter with Flame controlled by Telephone Diaphragm.

arc could be perfectly heard throughout a large hall. The striking experiment has since been frequently repeated.

We shall now describe shortly one or two other arrangements. The author has considerably simplified Simon's apparatus in the following way.* Since the correct design of the transformer is dependent on conditions which are

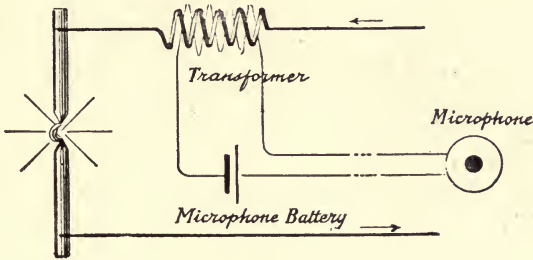

FIG. 21.

The Speaking Arc with Inductive Series-Control.

not constant, the use of one is entirely avoided, and an electric coupling takes the place of magnetic induction. The microphone circuit, which contains a considerable resistance, is put in parallel with the arc, so that a separate battery is not necessary (Fig. 22).

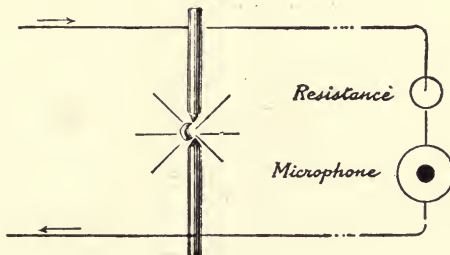

FIG. 22.

The Speaking Arc with Conductive Shunt-Control.

In place of the resistance one may introduce a number of cells, accumulators for instance, in the circuit, so that there is only a difference of a few volts left to drive the

* See *Mechaniker*, viii., p. 279, 1900.

microphone. Finally, in order to conduct the oscillating currents from the microphone entirely through the arc, and prevent them from spreading themselves over the leads, choking coils of considerable inductance are put in the circuit, which allow the continuous current to pass freely, but offer a very great resistance to the varying currents of the microphone. These latter, therefore, are almost entirely retained in the arc itself.

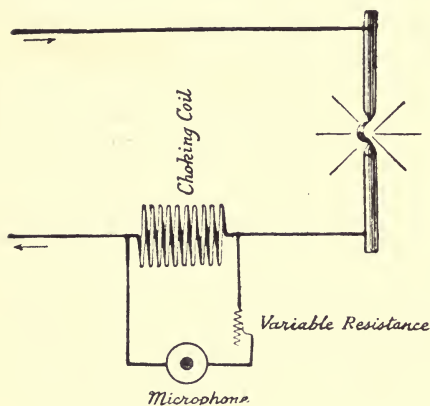

FIG. 23.

The Arc with Conductive Series-Control.

In place of putting the microphone in parallel with the arc it may have its terminals connected to two points on the supply leads, between which a resistance which gives a drop

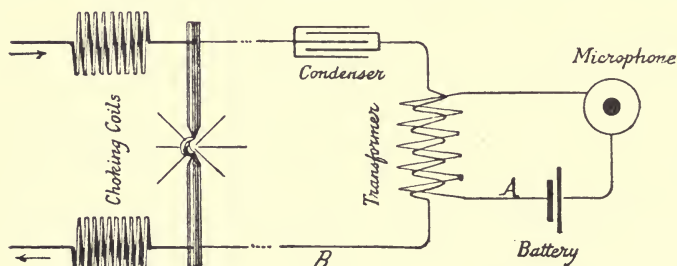

FIG. 24.

The Speaking Arc with Inductive Shunt-Control.

of from 4 to 6 volts is inserted (Fig. 23). In order that the microphone current should go through the arc the common part of their circuits must have a certain inductance. This

arrangement was described and used simultaneously, but independently, by Simon and the author.

Duddell's Arc.—Another arrangement, due to Duddell,* in which an inductive coupling is used, is shown diagrammatically in Fig. 24. In this also the microphone is in parallel with the arc, its circuit being connected inductively. The primary of a transformer is placed in series with the microphone and battery, while the secondary, which contains the same number of turns, has one end connected directly to one terminal of the arc, and the other to the other terminal through a condenser of from 3 to 5 microfarads. The condenser prevents the continuous current of the arc from passing through the transformer, while permitting the induced alternating current from the microphone to pass freely. For the same reason two coils of high inductance are placed in the arc lamp leads if the supply be from an accumulator or from a supply network. If a dynamo is used solely for the purpose of supplying current to the apparatus, and has no inductionless circuits, such as glow lamps, connected to it, these choking coils are unnecessary, as the machine itself possesses sufficient inductance. In the same way we find that the microphone currents are throttled and weakened by the inductance of the machine in the arrangements illustrated by Figs. 21 and 23. A condenser connected in parallel on the terminals of the dynamo partially obviates this difficulty.

Microphone in Field Magnet Circuit.—Finally there is an arrangement belonging to this class in which the microphone current influences the field magnets of the dynamo (Fig. 25). In this arrangement the electromotive force of the dynamo varies exactly in accordance with the

* W. Duddell, *The Electrician*, xlvi., Nos. 8 and *9, 1900, and *Phys. Zeitschr.*, ii., pp. 425, 440, 1901.

variations of the microphone current, so that the arc lamp supplied by the dynamo repeats whatever is spoken into the microphone attached to the dynamo. Simon used this apparatus at Frankfort-am-Maine, where he gave an "Arc Lamp Concert."

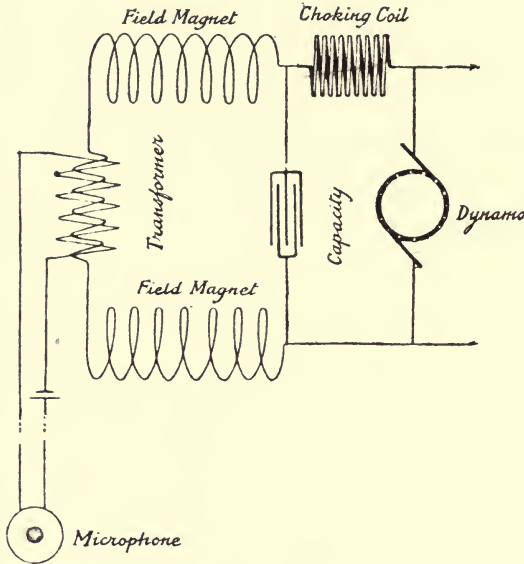

FIG. 25.

Speaking Arc with Field Magnets of Dynamo controlled by Microphone.

Theory of Talking Arc.—The theory of this remarkable phenomenon is that the variations of the microphone current cause corresponding variations in the amount of heat produced, according to Joule's law, in the arc; and these in their turn cause similar periodic changes in the volume of the gases through which the arc is conducted. The arc, therefore, generates sound waves.

In order to make the arc speak as loudly as possible, it is necessary that the oscillations imposed by the microphone on the constant current should be of as great amplitude as can be obtained.

Next in importance to the sensibility of the microphone comes the proper design of the transformer.

F. Braun* has shown, further, that the action should be greater while the arc current is increasing than under other circumstances, a suggestion which is confirmed in actual work.

Finally, it is advantageous to use as long an arc as possible, for which reason soft-cored carbons, or still better, carbons impregnated with salts, may be employed. With high voltage (say 160 volts across the arc) and currents of from 10 to 20 amperes arcs of between 5 and 7 cm. in length may be obtained.

Figs. 26 and 27 show a complete apparatus, constructed by Max Levy of Berlin from data supplied by the author, for the repetition of this interesting experiment. The transmitter consists of a Berliner granular microphone such as is generally used in the Imperial Post Office telephones, which is connected to the switch gear shown in Fig. 27. A hand-regulated arc lamp serves as receiver, which is fitted with a screen to prevent the eyes being dazzled by the light.

We may here shortly consider how the speaking arc may be made to perform the inverse function, *i.e.*, to act as a microphone.† In this case the sound waves cause alterations in the volume of the arc, and so produce oscillations of the current in its circuit. In Fig. 28 an arrangement for this purpose is shown, which Simon used in an experimental lecture before the Electrotechnical Society of Berlin on the 23rd of April 1901.‡ The arc is placed in the parabolic cavity H in the block B, the funnel T serving to concentrate the waves of sound.

From the above explanation of the speaking arc it will be seen that the temperature of the arc itself is subject to

* F. Braun, *Wied. Ann.*, lxx., p. 358, 1898.

† *E.T.Z. Rundschau*, xix., p. 321, 1898.

‡ *E.T.Z.*, xxii., p. 510, 1901.

rapid oscillations. But, according to the laws of radiation which have been so thoroughly worked out by modern physicists, every alteration of temperature causes a corresponding alteration in the intensity of the radiation. If, therefore, the temperature of the speaking arc oscillates,

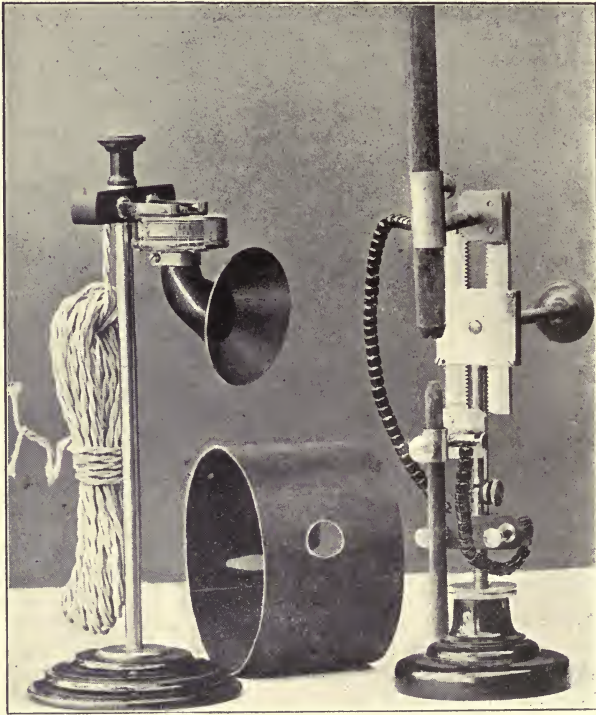

FIG. 26.
Speaking Arc Apparatus.

the radiation given out by it must oscillate in like manner.

The speaking arc thus belongs to the second group of photophonic transmitters, and fulfils its purpose as perfectly as can be desired, since by means of a parabolic mirror the

full power of the undulating rays of light may be directed towards the receiving station.

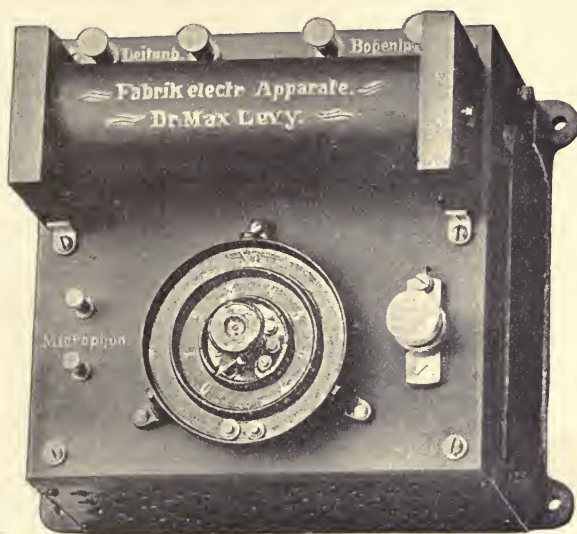

FIG. 27.
Regulator for Speaking Arc.

We shall consider later the most favourable conditions for the action of the arc as a photophonic transmitter, since these conditions differ in several essential points from those which give the best acoustic effects.*

As receiving apparatus for the conversion of the light oscillations into waves of sound, the photophonic instrument on Bell's principle, which we have described above, may be employed. A complete set of

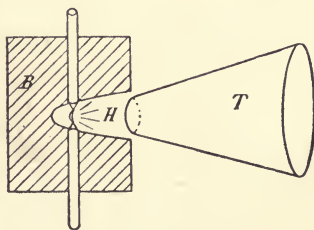

FIG. 28.
The Arc as Converter of Sound into
Electrical Vibrations.

* The author gave the essential points of difference for the first time on 19th February 1901. *Phys. Zeitschr.*, ii., p. 339, 1901.

apparatus of this kind for Light-Telephony, as we shall call this type of photophony, is shown diagrammatically in Fig. 29.

Let us next deal with the transmitter. The oscillating current of the microphone is superposed, by means of a transformer or otherwise, on the supply current to the lamp, causing like variations in the amount of light radiated. These undulating light rays are rendered parallel by a parabolic mirror, and thrown on to the concave mirror at the receiving station. There they are concentrated on a selenium cell, thus causing the battery current to vary in

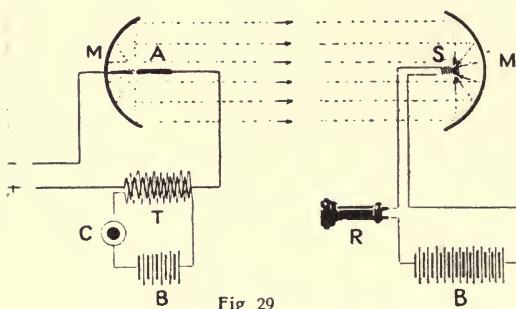

Fig 29

M, Mirrors ; *A*, Arc ; *T*, Transformer ; *C*, Microphone ; *B*, Battery ;
S, Selenium Cell ; *R*, Telephone Receiver.

like manner, so that articulate speech may be reproduced in the telephone by means of light.

It appears that Bell was the first to use the speaking arc as a photophonic transmitter.* In collaboration with H. V. Hayes in 1899, that is to say, very shortly after the discovery of the speaking arc, he showed the transmission of speech by means of an arc connected with a microphone and placed in a large parabolic mirror at the exhibition of electrical novelties held in the Madison Square Gardens, New York. As receiver a thermophonic arrangement was

* See *Electrical Review*, New York, vol. xxxiv., p. 325, 1899 ; *Mechaniker*, vii., p. 236, 1899 ; and *E.T.Z.*, xx., p. 459, 1899.

employed, similar to that already described, but with carbon threads in place of the ball of cork, which was situated at the focus of the reflector. The apparatus transmitted speech at a distance of 120 metres.

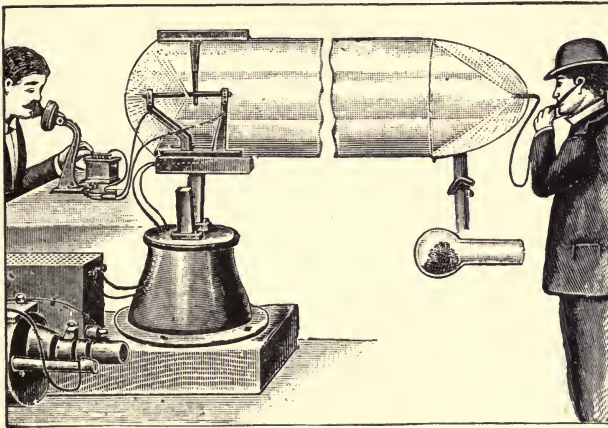

FIG. 30.

Bell and Hayes' Thermophone with Speaking Arc.

It is not known why Bell did not employ a photophonic receiver, such as a selenium cell, with battery and telephone in series, the most probable explanation being that he had not at the moment a suitable one ready.* In any case

* A historical account which differs essentially from that given above is to be found in a small volume entitled "The Radiophone," which was distributed at the Louisiana Purchase Exposition in St Louis, 1904, by the American Telephone and Telegraph Co. From the statements contained in it it appears that Mr Hammond V. Hayes, an engineer of the above-mentioned company, took up Bell's investigations on the electric arc, probably commencing with those shown at the Chicago Exhibition. Mr E. R. Cram, an assistant of Hayes', observed, in April 1897, that the electric arc undulates under the influence of the weakest of oscillating currents. It is stated that Hayes then developed from these observations a photophonic transmitter which is identical with the speaking arc. An American patent relating to this subject is dated 1st June 1897. If these statements

it is clear that he had very nearly approached the employment of a receiver of this kind. Similar researches were

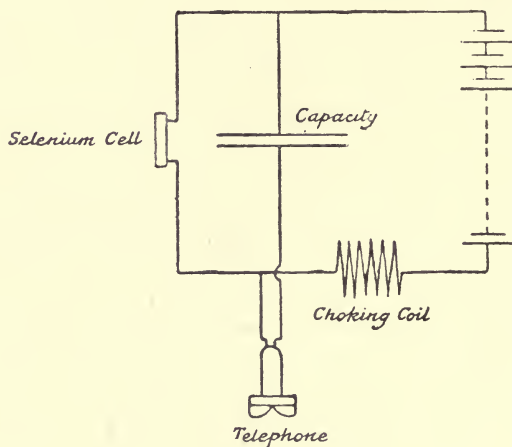

FIG. 31.

Receiving Circuit of Photophone.

then carried out by Simon * (latterly in conjunction with Reich) and the author.†

proved trustworthy the priority of discovery of the speaking arc, and of its application to radiophony, must be awarded to Hayes, since Simon's first publication dates from the end of 1897 (Erlanger Physico-Medical Society, 8th November 1897).

Addition by the Corrector.—The American patent concerned, No. 654,630 (completed on 31st July 1900), was filed on 7th June 1897, and contains the arrangements of the speaking arc shown in Figs. 21, 22, 24, and 25. Both photophonic and thermophonic receivers were used. Hence the priority of Hayes and Bell in regard to the speaking arc is no longer a matter of doubt.

* H. Th. Simon, *Phys. Zeitschr.*, ii, p. 253, 1901; *E. T. Z.*, xxii., p. 510, 1901. That Simon was aware of Bell's adaptation of the speaking arc to the purpose of radiophonic transmission is proved by a letter to the editor of the *Zeitschrift der Mechaniker*, dated 29th September 1899, and published in that journal, vii., p. 237, 1899, in which he doubts the effectiveness of Bell's arrangement.

† E. Ruhmer, *E. T. Z.*, xxii., p. 196, 1901; *Phys. Zeitschr.*, ii, pp. 325

Passing over a large number of laboratory investigations, we shall next shortly describe the more important of

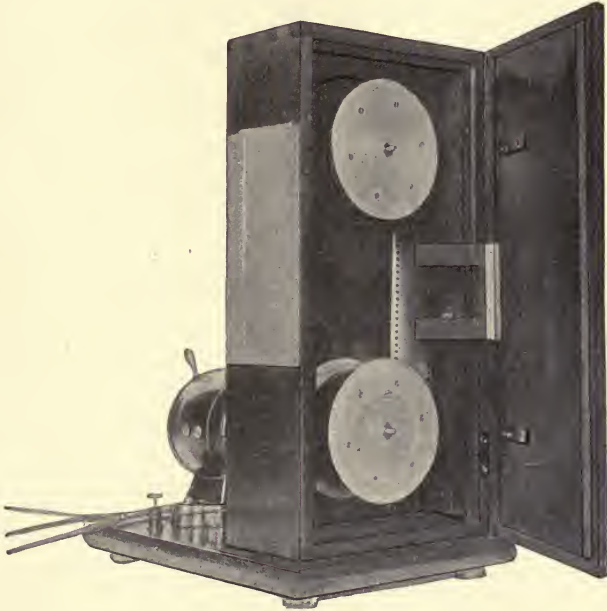

FIG. 32.

Ruhmer's Photographophone, Internal Arrangements of Receiver.

Simon's researches,* and then go into the author's numerous attempts to adapt light-telephony to practical uses.

and 339, 1901. The author had already in 1900 had communications with the Elektrizitats A.-G. vorm. Schuckert & Co., in regard to this matter.

* Simon's first demonstration of light-telephony was given at the meeting of the Physical Society in Frankfort a/M. on the 8th of September 1900. The condition of his apparatus must, however, have been very unsatisfactory at that time if one takes into account the failures which occurred at a later lecture, before the Frankfort Electrotechnical Society on 6th February 1901, concerning which the author has written an exhaustive report.

C

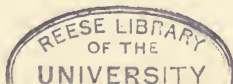

Simon's Light-Telephone.—Simon's first experiment over great distances was carried out at Nurnberg in September 1901. A Schuckert's searchlight, with a parabolic mirror of 90 cm. diameter and 40 cm. focus, or a similar apparatus of 150 cm. diameter and 60 cm. focus,

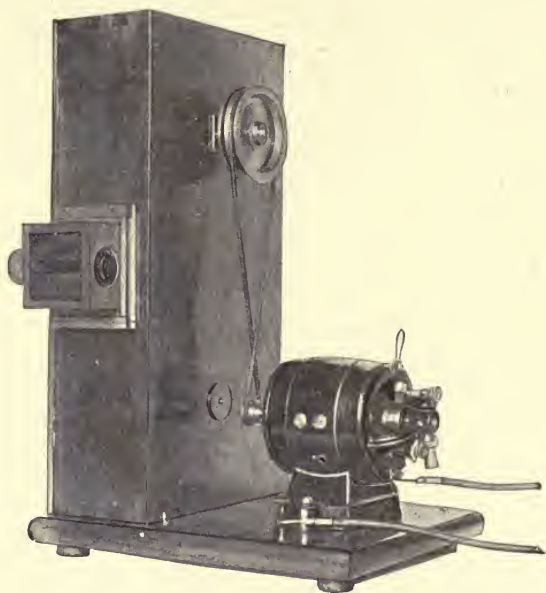

FIG. 33.

Recorder of Ruhmer's Photographophone.

was used as transmitter. At the receiving station a 30 cm. lens or a 90 cm. mirror was used to concentrate the light on the selenium cell. Speech was clearly transmitted over a distance of 1.2 km. with this arrangement.* This dis-

* Simon and Reich. Demonstration to the Scientific Conference in Hamburg, 24th September 1901, and *Phys. Zeitschr.*, iii., p. 278, 1902, and apparently there was also another lecture on 23rd September 1901. The sender (a Schuckert's searchlight of 80 cm. aperture and 32 cm. focal length) was placed on the roof of the Hamburger Wilhelm's Gymnasium, the receiver being distant about 1 km. at the State Physical Laboratory.

tance was increased to 2.5 km. in a later experiment at Göttingen. Nothing further has been published on these researches.

Simon used as transmitter the arrangement shown in Fig. 23. At the receiving station the apparatus shown diagrammatically in Fig. 31 was employed. The telephone and a capacity were connected in parallel with the selenium cell so that the continuous current through the cell did not pass through the telephone.

CHAPTER IV.

THE PHOTOGRAPHOPHONE.

The Author's Experiments.—Let us now go somewhat more thoroughly into the author's work on this subject. These experiments arose from the results already obtained with the speaking arc in the commencement of 1900. In order to determine the best conditions for photophonic purposes, the author attempted to record the variations in intensity of the arc when reproducing speech by means of photography, since they are too rapid to be observed by the eye directly. For this purpose he employed a cinematograph of the simplest type. (Figs. 32 and 33.)

Two rollers are placed in a light-tight box and off one of them on to the other a photographic film is wound with constant velocity. A small electric motor drives the rolls so that the film passes with a velocity of several metres per second. The film travels in front of a cylindrical lens which concentrates the light of the arc upon it.* The film is afterwards taken off and developed and fixed in the ordinary way. The finished film shows the variations of the light just in proportion to their amplitude. They arise chiefly at the positive crater.†

It was only after many laborious attempts that films so clear as those shown in Figs. 34 and 35 were obtained. The alternately light and dark strips which give the appear-

* The original apparatus is now in the German Museum at Munich.

† Birrenbach ("Theory and Applications of the Electric Arc," Hanover, 1903, p. 21) shows that about 85 per cent. of the total light comes from the positive crater, about 10 per cent. from the negative, and only 5 per cent. from the arc itself.

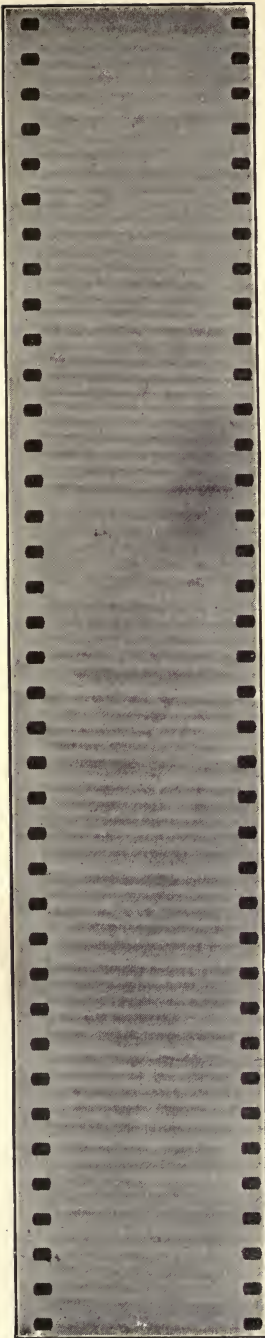

FIG. 34.



FIG. 35.

Photographophonic Records.

ance of great irregularity are in reality exceedingly regular and harmonic, only changing their order with the change of the corresponding sound of speech. Each sound gives its own group of lines and may be easily recognised and read from the photo-phonographic record.

When the most favourable conditions for the action of the speaking arc had been determined, to which we shall return later, we were able to photograph the light variations with such wonderful clearness that it occurred to us

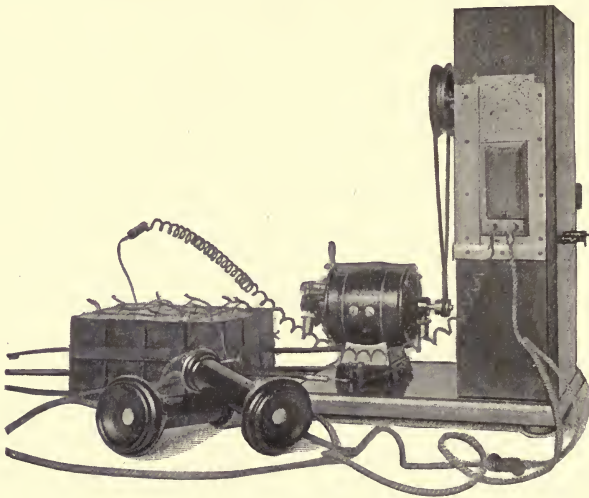

FIG. 36.

The Reproducer of the Photographophone.

to use the photogram for the reproduction of sound waves, an idea which was actually realised.

For this purpose the film is made to travel in the same direction and with the same velocity as when taken, behind the objective of the apparatus, while the arc lamp, now silent, is used as a source of illumination. Behind the film a selenium cell is temporarily fixed, which is put in series with a battery of small dry cells and a pair of telephones (Fig. 36). Through the varying strength of

the blackening of the film an illumination of the cell is produced which corresponds in its variations with the received sound waves, and is converted into sound in the telephones.

It is truly a wonderful process: sound becomes electricity, becomes light, causes chemical actions, becomes light and electricity again, and finally sound.

When Chladni showed his vibrating plates to the Emperor Napoleon the latter cried out in surprise, "Marvellous, this Chladni lets us see sounds!" To-day we have achieved something further. Not only can we see the tones but can hear again the visible sounds; we fix the music and speech which has become light on a gelatine strip, which retains them until all the sensations are again called forth which we experienced when the sounds struck our ears for the first time.

The reproduction of speech by this photographic phonograph is astonishingly clear, and in strength resembles the enunciation of a good telephone when in ordinary use. The instrument has been named the Photographophone by the author and is shown in Fig. 37. It has the advantage of the ordinary wax-cylindrical phonographs in that the reproduction is purer and is free from the unpleasant noises caused by imperfections in the mechanism.* In addition to this, one can obtain from such a speech photograph as many reproductions as desired, each of which will give back the original sounds with equal exactitude.

While for the production of useful photo-phonographic records the proper conditioning of the source of light is of the greatest importance, it is the selenium cell which plays

* *Mechaniker*, ix., pp. 75 and 169, 1901; *Phys. Zeitschr.*, ii., pp. 339 and 498, 1901; *Ann. d. Physik.*, v., p. 803, 1901. The apparatus was exhibited at the Berlin Polytechnic Society on 12th December 1901, at the Society Railway of Berlin on 11th February 1902, and in the Beethoven Hall of the Philharmonie in Berlin on the occasion of the Gramophone Concert on 9th April 1903.

the chief part in the reproduction of the sounds. One sees that, among other things, these photographophonic experiments of the author give results which are similar to those obtained by light-telephony.

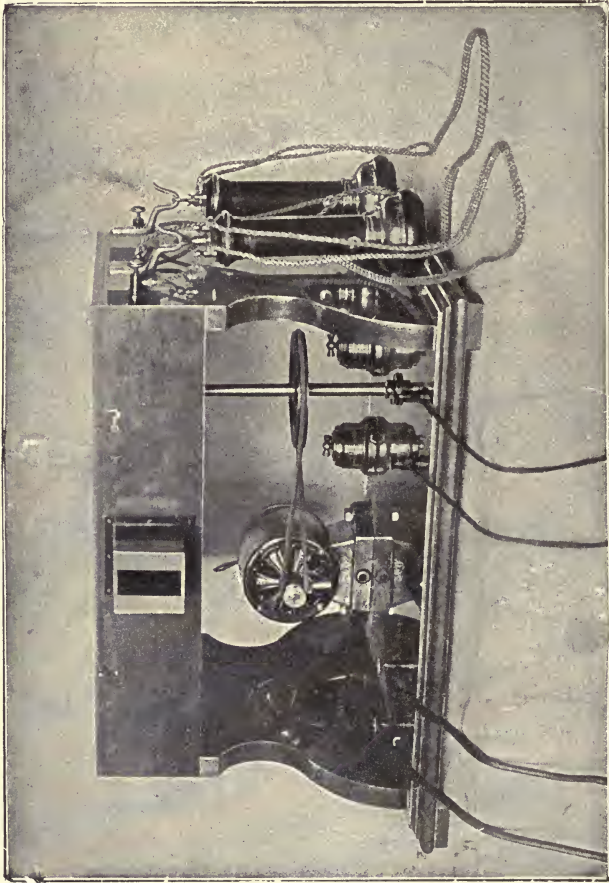

FIG. 37.
The Photographophone.

The Selenium Cell.—The necessity of finding a very sensitive selenium cell was the cause of an exceedingly thorough investigation of the remarkable properties of

selenium. A long series of experiments and researches led eventually to the construction of a selenium cell in a high degree suitable to the existing conditions.

Further information on this subject is given in the author's brochure, "Selenium and its Importance in Electro-technics," Berlin, 1902, and also in a paper on the construction and sensibility of selenium cells, which appeared in the *Physicalische Zeitschrift*, iii., pp. 468-474 (June 1902).

It may be mentioned that both flat and cylindrical cells were described in this paper, the latter form being peculiarly suitable for use in the parabolic mirror of a photophone.

Unglazed porcelain or soapstone is used for the core of these cells since selenium adheres firmly to either. On the surface of the core fine notches in the form of a double-threaded screw are stamped or cut in which two metal wires are wound while hot. These wires form the electrodes of the cell and lead to the terminals. The pitch of the double screw is so chosen that the unlike poles of the cells lie very close to one another. The selenium is put on in the melted condition so as to cover all the spaces between the wires, and then is converted into the modifica-



FIG. 38.
Flat Selenium Cell.

tion which is sensitive to light. Thus the current flows in the cell from one wire, the anode, to another wire, the kathode, through the cell.

In Figs. 38 and 39 are shown flat cells of this form, one in a polished wooden case with hinged cover, and the other in ebonite with a sliding lid. The cylindrical cells were enclosed in an evacuated glass bulb to shield them from damage and from the effects of the air. The bulb is fitted with a collar and contacts, so that the selenium cell may easily be put into an ordinary lamp holder (Fig. 40).



FIG. 39.
Flat Selenium Cell.

Experiments on the Havel.—

The selenium cells were, however, not only improved in construction, but also in quality; their sensibility was increased, and, which is quite as important for practical purposes, their resistance diminished. Already in the commencement of 1901 the author* pointed out that he should be able to bridge over much greater distances with his perfected cells than with those obtainable at that time in commerce. And, in fact, the author's results with his improved selenium cells, beginning with small distances in the laboratory and in demonstrations at the Exhibition of Electrotechnical Novelties in the Architects' Hall, on 19th March 1902, and in the Imperial Post Museum on 9th April 1902, were so astonishingly satisfactory that he was requested to continue the experiments at greater distances.

* *E.T.Z.*, xxii., p. 198, 1901.

CHAPTER V.

LIGHT-TELEPHONY AT USEFUL DISTANCES.

THE long and laborious researches previously undertaken in the laboratory now bore fruit, so that on the first attempt in the laboratory of Nature photophonic communication was established at greater distances than had ever been previously attained to. The Wannsee near Berlin was chosen as a suitable field for the experiments. The uninterrupted view over the broad waters of the Havel and the possibility of obtaining electrical energy from the central stations on its banks rendered the situation peculiarly advantageous.

In addition there was at this time (summer 1902) a Motor Boat Exhibition, at which the Hagerer Accumulator Company were showing the electrical motor boat "Germania," which was fitted by Messrs Schuckert with a torpedo boat searchlight of 35 cm. aperture. Through the kindness of the companies

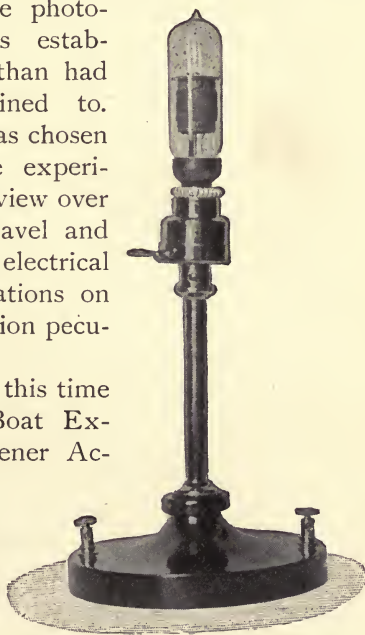

FIG. 40.
Cylindrical Selenium Cell Enclosed in
Glass Bulb.

concerned both motor boat and searchlight were placed at my disposal for the purpose of the experiments I

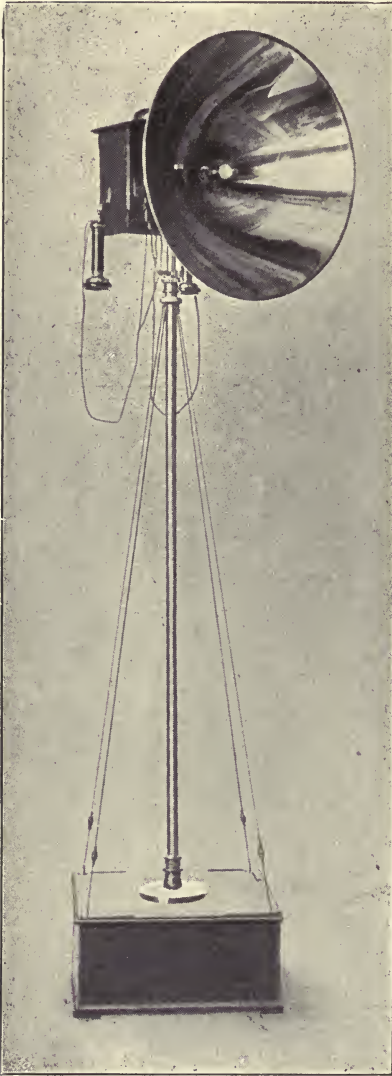

FIG. 41.
Modern Photophonic Receiver.

had in view. When the arc lamp had been fitted with a microphone and transformer, and the receiver placed in a reflector of about 50 cm. aperture and set up on a jetty near the Wannsee Electricity Works (see Figs. 41-43), light-telephony could be established between the boat and the land, and the distance between the stations gradually increased by backing the boat outwards.*

In Fig. 45 a plan is given which shows the stretches over which speech was transmitted.

1. Experiment on the evening of 4th July. Right across the Wannsee, about 1.5 km. Clear air.

2. Experiment on the evening of 8th July. From the Motor Boat Exhibition, Wannsee Station, across the Wannsee towards the neighbourhood of Neu Cladow, about 3.8 km.

* Also see E. Ruhmer, *E.T.Z.*, xxiii., p. 859, 1902.



FIG. 42.

Ruhmer's Photophonic Receiver on the Wannsee.

Misty. The sending station was in this case on board the motor boat "Germania," lying at the quay, while the receiving station was on board the motor boat "Loreley."



FIG. 43.
Photophonic Reception at Night on the Wannsee.

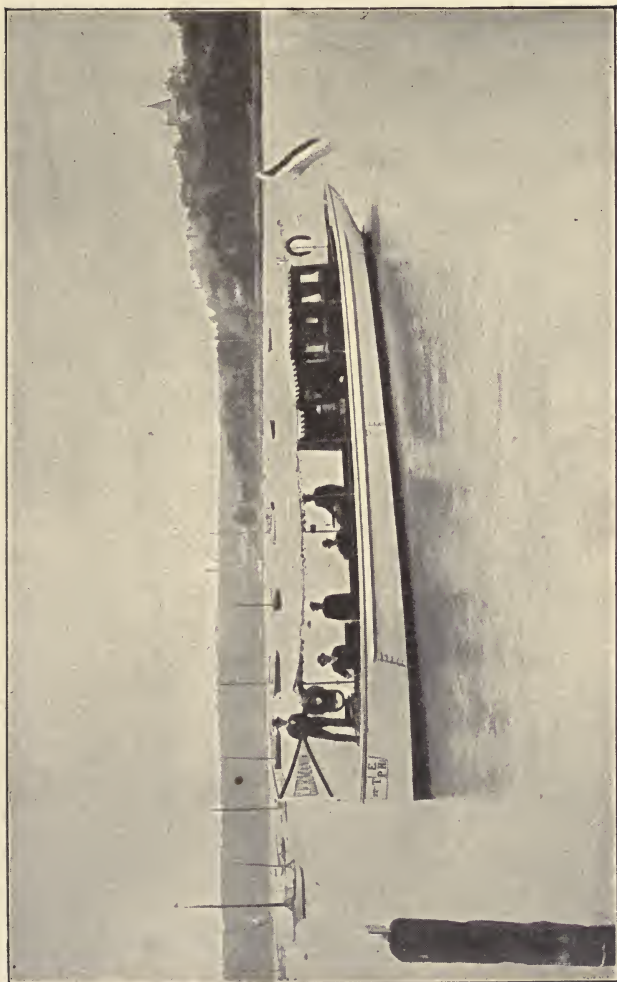

FIG. 44.
Photophonic Transmitter on the Bows of the "Germania."

3. Experiment on the evening of 9th July. Across the Wannsee, about 1.6 km. Heavy rain. This experiment had to be broken off at 1.6 km., because one of the assistants knocked over the accumulators at the receiving station by mistake in the dark.

4. Experiment on 16th July, afternoon. In the direction of Schwanenwerder, about 2.6 km. Weak sunshine.

Since the geographical formation of the Wannsee set

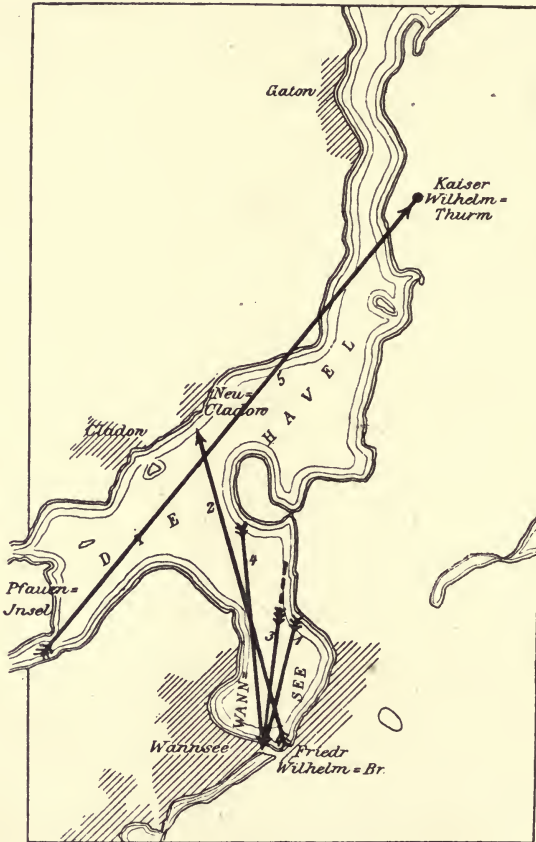

FIG. 45.

Sketch Map of the Wannsee and Havel.

a limit to the extension of the research, a new series of experiments was undertaken on the Havel, after many difficulties had been overcome, and were carried on up to the greatest distance possible under the circumstances.

5. Experiment on the evening of 25th July. Receiving station on the platform of the Kaiser-Wilhelm Tower on the Karlsberg in the Grunewald; the sending station on the "Germania" in the direction of the Pfauen Island near Potsdam. Thick air, slightly misty.

The transmission was in all cases good, and in this last experiment surprisingly loud and clear.

X As the apparatus was only of the simplest, it was only possible to telephone in one direction. Communication with the sending station was therefore established by means of optical signals, for which purpose a glow lamp was used in the earlier experiments, and a small stage lime-light in the later ones (see Fig. 46). In the last experiment, from the Kaiser - Wilhelm Tower, an acetylene signalling lamp was used.

Berlin Experiments.—As local conditions prevented the extension of the experiments on the Wannsee or Havel, and since the limits of the possibilities of the apparatus had by no means been reached, the author, in the autumn of 1902, in conjunction with Messrs Siemens, Schuckert, and Co., fitted out two permanent stations. Tests were then made of the system in all different kinds of weather, and the practical utility of the apparatus correspondingly increased.

The sending station was at the Berlin works of the Schuckert Company, in Kopenicker Road, while the receiving station was at the parish school in the Baumschulweg, about 2.5 km. distant. A Schuckert's searchlight with a very perfect parabolic mirror of 60 cm. diameter was used as transmitter, while the receiver was the same as that used on the Wannsee except that a somewhat larger mirror of 60 cm. diameter was fitted to it. In order to be able to speak back, both stations were supplied with apparatus for transmission and reception. The torpedo boat searchlight, with 35 cm. aperture (Fig. 48), which had been used in the experiments on the Wannsee, was installed in the



FIG. 46.—Photophonic Transmission by Night ; with Speaking Arc.

Baumschulweg and supplied with current from a battery of accumulators (Fig. 49). The apparatus shown in Fig.

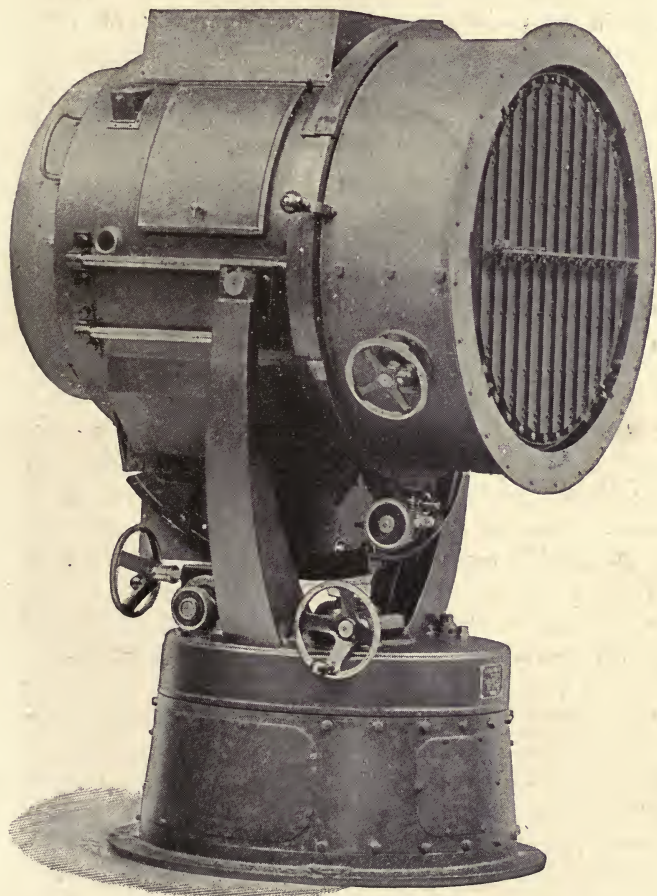

FIG. 47.

Large Searchlight used as Transmitter.

50 was used in the Schuckert works, its reflector having a diameter of 45 cm.

The transmission was excellent here also, particularly

as regards the loudness of the enunciation, which, both by day and in wet weather, was as good as could be desired. This is all the more remarkable since the positions were exceedingly unfavourable, the transparency of the air

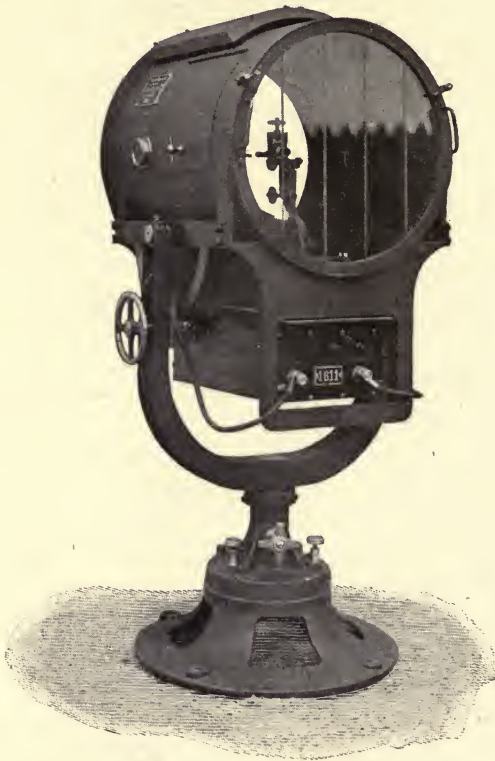

FIG. 48.

Small Searchlight used as Transmitter.

between the stations being much reduced by the clouds of smoke rising from numerous factories in the neighbourhood, and by the steam and smoke of many railway trains close by.

Simultaneous Conversations in both Directions.— Speech was] also transmitted simultaneously in both directions, the two coincident beams of light from the searchlights not interfering with one another in any way. Transmis-

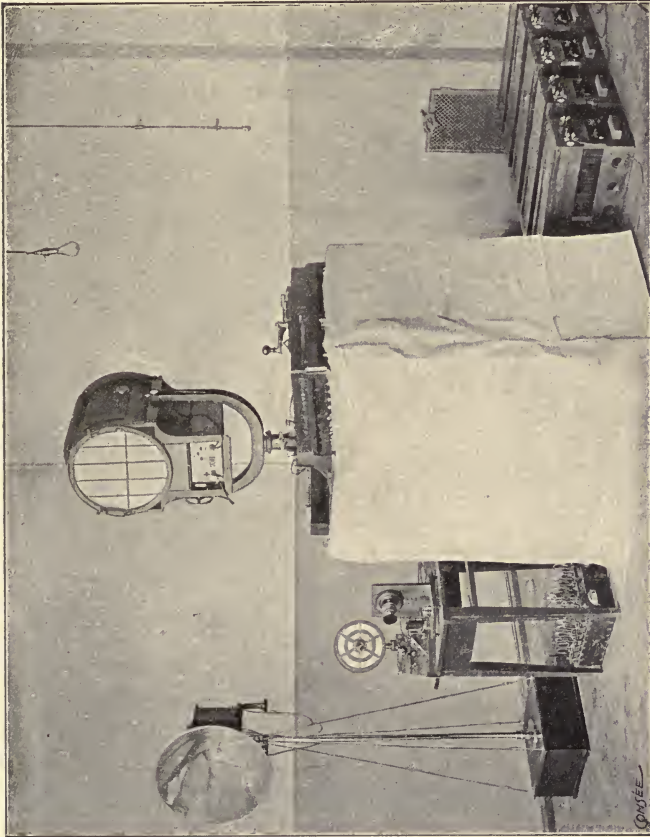

FIG. 49.—Complete Portable Apparatus for Photo-telephony and Telegraphy.

sion was possible over this distance with even the small stage reflector. Fig. 51 shows an arrangement of this kind which is also suitable for demonstrations on a small scale. Later on, the Baumschulweg station was fitted with a glass

mirror of 90 cm. aperture as receiver in combination with one of the flat selenium cells previously described (Fig. 52). The experimental results collected during several months' work at these stations justified an attempt to considerably increase the distance. As a suitable point for the receiving station a water tower on the Falkenberg, behind Grunau in the Mark, was chosen, which was very kindly put at our disposal by the superintendent of the garden, Mr Buntzel. Since there were only three very small windows on the side



FIG. 50.

Portable Photophonic Receiver.

of the tower nearest to Berlin, it was necessary to support the 90 cm. receiving mirror outside the tower between a pair of projecting beams, an arrangement which greatly increased the difficulty of placing the selenium cell exactly in the focus of the mirror (Fig. 53). The metal reflector used at first (Fig. 54) was later on replaced by the parabolic glass mirror from the Baumschulweg, since the latter was a much better reflector (Fig. 55).

At such distances as these, the spreading of the rays of

X
light from the searchlight is very considerable, the diameter of the beam being as much as several hundred metres. It is only when one realises that, without taking account of the very considerable absorption of light by the air, only about the one hundred-thousandth part of the light radiated by the sender reaches the mirror and acts on the selenium cell, that one obtains a proper estimate of the extreme sensitiveness of the electric selenium-eye.

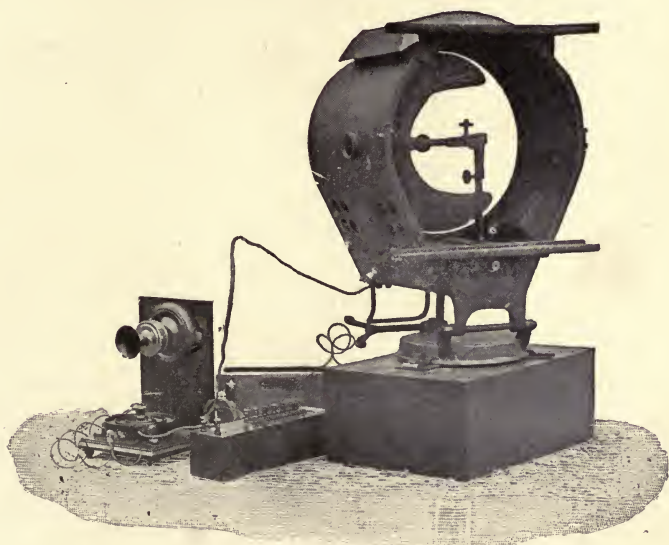

FIG. 51.

Portable Photophonic Transmitter.

The words spoken into the microphone in Berlin were still clearly audible at this distance. By using a larger receiving mirror the distance of transmission might apparently be greatly increased, though of course the stations would have to be so situated that the curvature of the earth, already quite appreciable at this distance, did not interfere.

The author's experimental results described above prove clearly that light-telephony is of practical import-

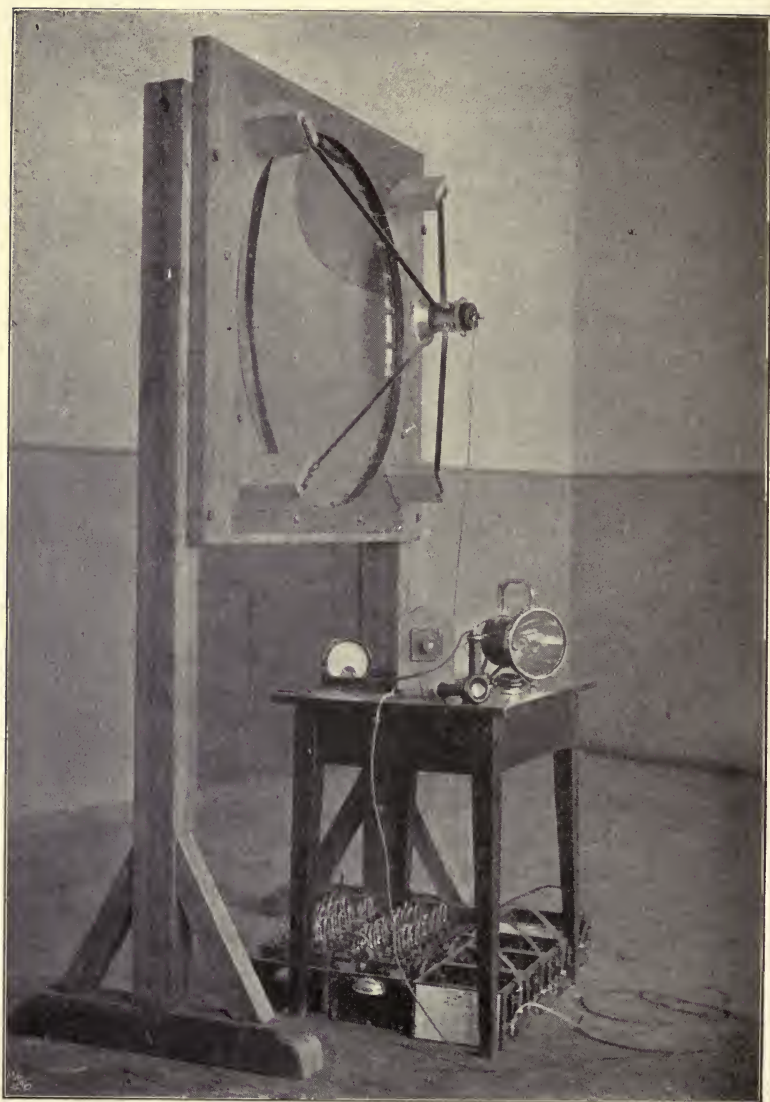

FIG. 52.
Receiver used in Long Distance Experiments near Berlin.

ance, more particularly in the Navy, for which in the spring (25th to 28th May) of 1903 the author carried out some experiments on board the warships "Neptun" and "Nymphe," using their ordinary searchlights for the purpose of light-telephony.

The employment of light-telephony appears possible even for military purposes. Figs. 56 and 57 show a



FIG. 53.

The Tower and Receiver at Falkenberg.

portable set of apparatus designed for use in the field. The searchlight is placed on a waggon and is supplied with current from a portable petrol motor and dynamo. The receiving apparatus is made as simple and as light as possible so that it may be easily moved from place to place.

The author continued his researches in 1904 in order to improve his methods still further. The transmitting

station was placed on the electric barge "Teltow" (Fig. 58), with which some experiments were made on the Griebnitzsee (near Neu-Babelsberg) and on the Havel.

Another station was erected later on the tower of the

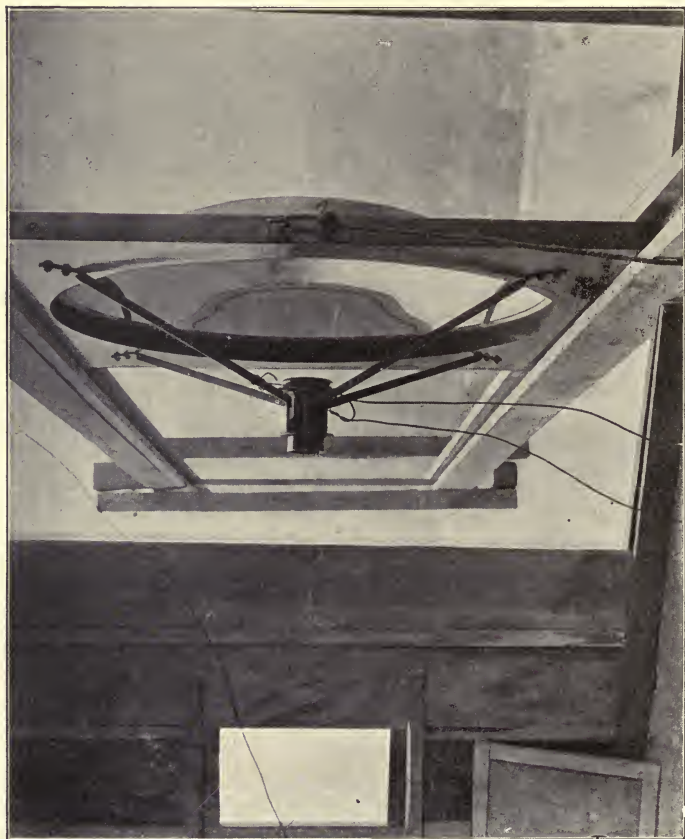

FIG. 54.—The Large Mirror and Flat Selenium Cell of the Receiver at Falkenberg.

Astrophysical Observatory on the Brauhausberg, near Potsdam, by permission of Dr H. C. Vogel (Fig. 59). The transmitter was a searchlight of 60 cm. enclosed in an aluminium case and standing on a tripod. The receiver

was first placed on the "Teltow" and later on a tower of the Royal Castle on the Pfingstberge, near Potsdam.

It was hoped to continue the experiments as far as the water tower in Steglitz (20 km.), or even to Marienberg, near Brandenburg a/H., which would have been a distance of 37 km., but they had to be broken off because the searchlight was required for use in the operations in South-

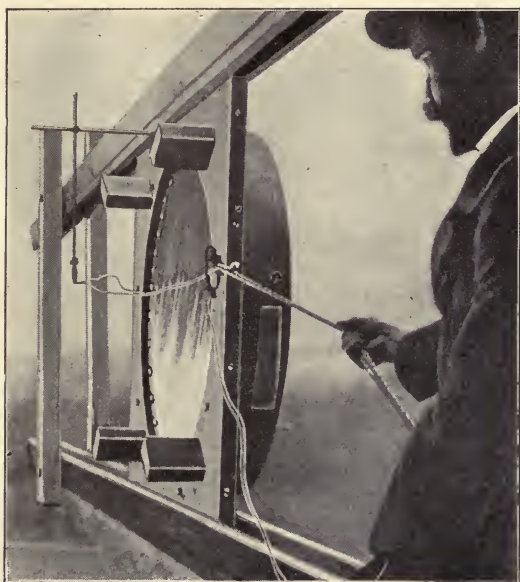

FIG. 55.—Adjusting the Receiver.

West Africa, and a similar one was not to be had, while a heavier one could not be put on the tower, and a smaller was not sufficiently powerful.*

We shall now consider the most favourable conditions as they have been determined by these very numerous experiments.

* The apparatus used in the Wannsee experiments was shown at the recent Exhibition of Inventions at the Zoological Gardens in Berlin. (See Figs. 59A, 59B.)

Best Conditions for Light-Telephony.—In the transmitter the chief part is played by proper superposition of as large as possible microphone currents on the supply current of the arc lamp. For this purpose an exceedingly

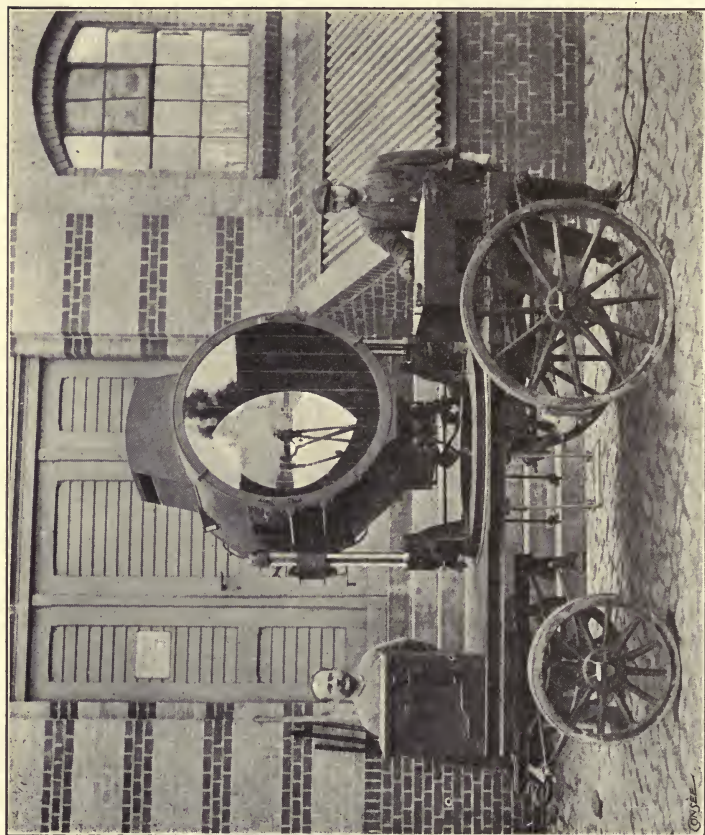

FIG. 56.—Military Transmitter.

sensitive microphone, which will stand a large voltage and carry a considerable current, and a properly designed transformer are necessary. In the speaking arc, where large changes of volume are required, a long arc is best. Here,

on the contrary, we need large variations of the intensity of light radiated, since it is on these variations and not on the total amount of light radiated that the transmission depends. It is therefore advantageous to keep the arc small and to use as little current as possible. The less the constant supply current of the arc, the greater, in proportion, are the variations due to the microphone current, and therefore the greater are the variations of the radiation from the positive crater of the arc. As we have seen above, these variations of the intensity of the light are only observable if the current in the arc be small, and they become less and less as it increases, until with very large currents, such as 100 amperes or more, the brilliancy is no longer proportional to the current, and hence the oscillations of the latter do not affect the former, so that there is no conversion of electric into light waves.



FIG. 57.
Military Receiver.

It appears thus, that if the current be small any increase of it causes an increase of the temperature of the positive crater, while if it be large the temperature remains constant and the crater only increases in

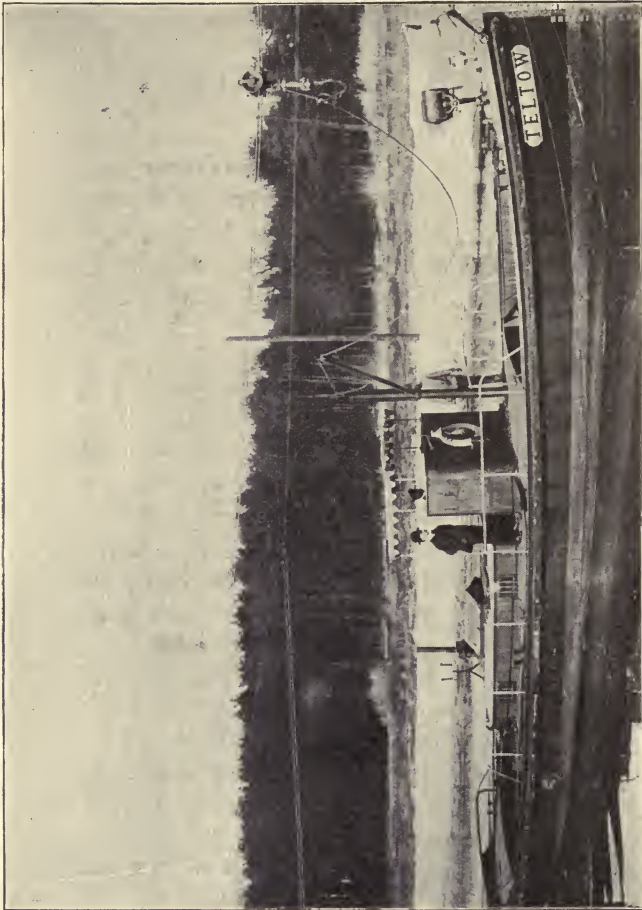

FIG. 58.—The Barge "Teltow" fitted with Searchlight Transmitter.

size.* The use of a positive crater of small diameter is also of importance on account of its position in the focus

* F. Nerz, "Scheinwerfer und Fernbeleuchtung," Stuttgart, 1899; O. Krell, "Der Gegenwärtige Stand der Scheinwerfertechnik," Vorträge, Schiffbautechnische Gesellschaft, 18th November 1904. See also M. Reich, *Phys Zeitschr.* vii., p. 73, 1906; particularly section 15, p. 85.

of the mirror, its exact adjustment being less necessary than in the case of a larger crater.

The less the area of the source of light the less is the

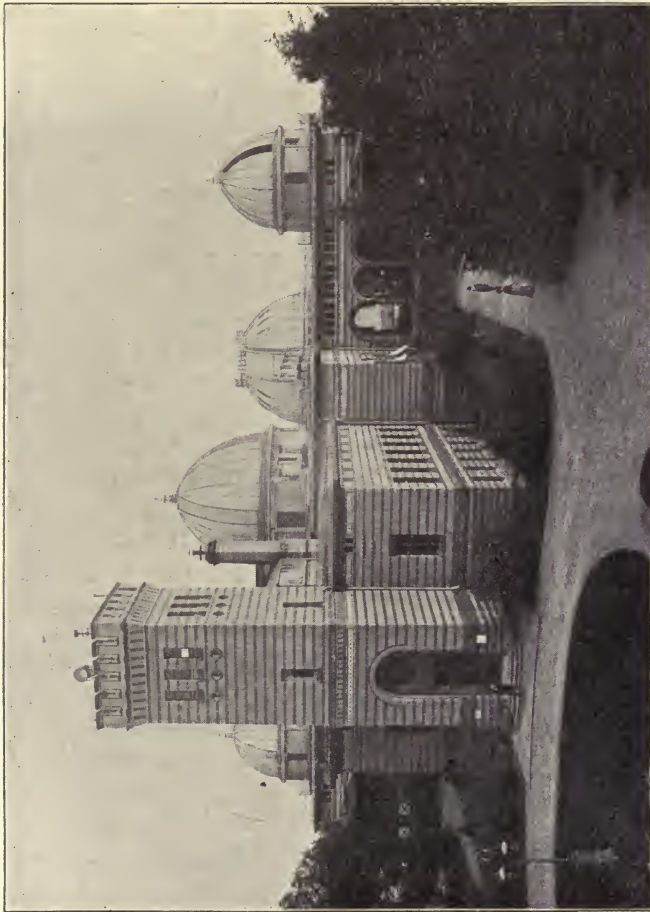

FIG. 59. — Transmitter on the Tower of the Astrophysical Observatory on the Brauhausberg.

divergence of the beam of light reflected from a properly ground mirror, and therefore the greater is the amount of light collected by the mirror of the receiver and concentrated on the selenium cell.

As the theory of the parabolic mirror shows, it is possible to reduce the divergence of the beam from a large source of light by increasing the focal length of the mirror. This must always, however, go hand in hand with an increase of the diameter of the mirror in order that as great a proportion of the light may be used.

It is therefore necessary in researches on light-telephony to use a properly figured parabolic mirror with good reflecting surface and large aperture and focal length, in the focus of which is placed an arc lamp fed by the smallest practicable current.

The large Schuckert's searchlight, with its almost mathematically perfect parabolic glass mirror, silvered on the back, served the purpose excellently; and yet with this, even though a very small arc was used, the divergence at great distances was very considerable, as we have seen in the Grunau experiments. From 2 to 3 amperes were used as a rule, though for great distances from 4 to at most 10 may be used with advantage. With greater currents the loudness of the transmitted speech becomes notably less.*

For small currents carbon rods of 5 mm. for the positive and 4 mm. for the negative electrode are sufficient; while for larger currents carbons of from 8 to 6 mm. are suitable. The material of which the electrodes are formed is of considerable importance, since the temperature of the crater must vary rapidly, and large thermal capacity of the electrodes hinders this variation. If a solid carbon be used, the constant shifting of the positive end of the arc, which occurs even more with a metal anode, is so troublesome that for practical uses a soft cored carbon, which fixes the point at which the arc terminates, is preferable. The longer and the more unstable the arc (from 4 to 7 mm.

* This is one of the causes why the light-telephonic apparatus at the St Louis (1904) Exhibition worked badly. The supply current of the sender was about 20 amperes. The receiving station is shown in Fig. 60.

with 60 to 90 volts) the better are the results obtainable. The loudness of the transmission is quite astonishing at

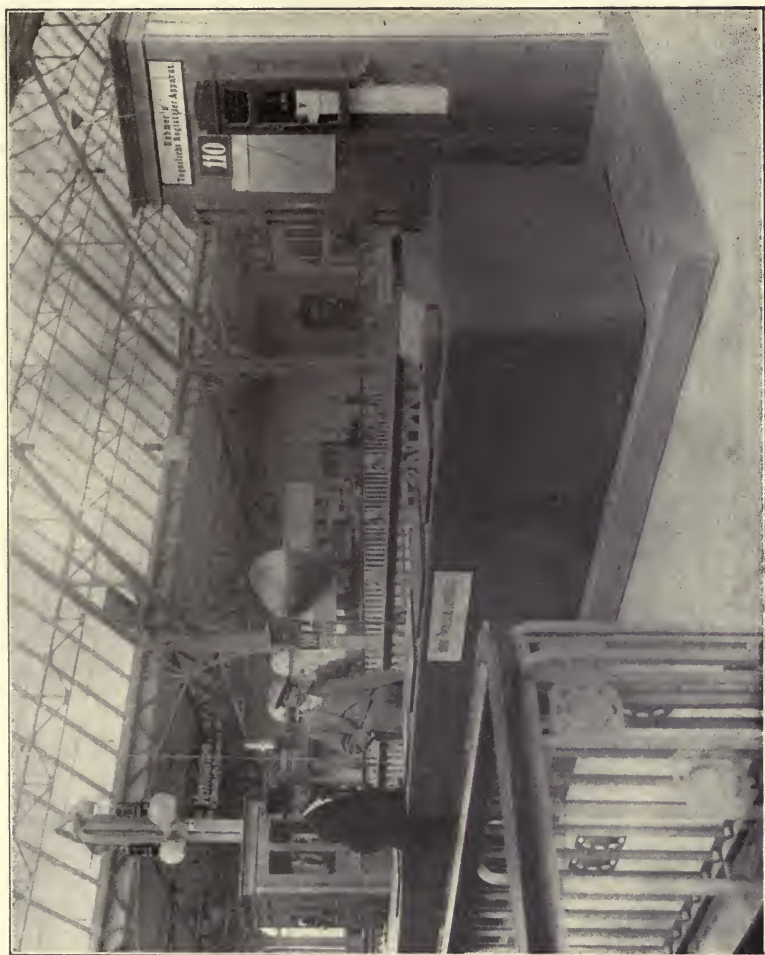

FIG. 59A.

the moment the arc breaks, as the latter is then attached only to a single point on the electrode. The effects of higher voltages were investigated during the experiments

on the boat "Teltow," but little advantage was found in using more than the usual arc voltage of 60 to 90 volts with a supply current at 110 volts.

There are no further factors which require consideration



FIG. 59B.

in the transmitter; only the discovery of a new source of light with a greater specific brilliancy could lead to a further advance.

We come next to another important point, namely, the

proper direction of the searchlight beam towards the receiver. This adjustment is often very difficult, particularly from a moving platform such as a ship's deck. In this case it is necessary to suspend the searchlight on gimbals. In the evening and at night the person in charge of the sender sees the beam of light, and, if the distance be not too great, the reflection from the illuminated receiving mirror. At greater distances, however, say from 3 km. upwards, one cannot recognise illuminated objects, and by day, of course, the beam is invisible and it is impossible to observe its direction. The searchlight must therefore have a telescopic sight attached to it whose axis is parallel with the axis of the searchlight.

Atmospheric Conditions.

— In order to correct a widely diffused error we may here state that the results by day are quite as good as those by night. Indeed, one may even illuminate the selenium cell by means of a powerful but constant source of light without in any way reducing the loudness of the transmission. Direct sunshine must, however, not be allowed to fall on the mirror at the receiving station or the selenium will be melted and the cell rendered useless. In cases in which it is necessary to direct the mirror towards



FIG. 60.

Receiver at the St Louis Exhibition.

the sun, it is only needful to shelter it from the direct sunshine by means of a screen projecting above it.

The transparency of the atmosphere is of the greatest importance, both as regards range and clearness of transmission. When one considers that the atmospheric absorption varies from 2 to 50 per cent. per km., and even more than this, one can understand the great influence of this factor. Rain and snow affect transmission, but not to the extent one would expect. In thick fog light-telephony is of course impossible over anything but the smallest distances.*

Receiving Apparatus.—Let us consider finally the more important factors at the receiving station. The larger the reflector the more light is concentrated on the cell, and therefore the greater are the variations of illumination and of the currents in the microphone circuit. It is not important that the mirror should be exactly parabolic, as the light is concentrated not on a point but on the relatively large sensitive surface of the cell. The mirror must, however, be made of a material which has a high coefficient of reflection. In place of the exceedingly expensive Schuckert's glass searchlight reflectors one may use for this purpose metallic mirrors, the best being of German silver, which may be constructed comparatively lightly and cheaply in large dimensions.

Cylindrical selenium cells should be used with mirrors of short focal length, and flat ones if the focal length be longer. With very large receiving mirrors the latter form is preferable, *i.e.*, a somewhat flat mirror should be chosen whose focus is outside the body of the mirror, and a flat

* In southern countries the transparency of the atmosphere is much greater than in Europe. I have been informed that heliographic communication has been maintained up to distances of 100 and even 160 km. between Haribib and Outjo and Windhuk and Keetmanshoep in South-West Africa. See also Loebell's "Jahresbericht über das Heer u. Kriegswese," 1906.

cell should be employed. At very large stations a number of mirrors might be used instead of a single one. The author has designed an arrangement of this kind in which six mirrors of 2 metres diameter surround a seventh, and hoped to obtain a range of 100 km. with it. The plan has, however, not yet been carried out.

The selenium cell has naturally a very great influence on the receiver. We have already made clear the points of view which determinè the choicè between a cylindrical and a flat cell. In order to obtain the greatest increase of the intensity of illumination, which obviously depends on the relation of the area of the mirror to that of the cell, the latter must be as small as possible. Electrical conditions, however, set a limit to improvement in this direction. Small cells have so great a resistance to the electric current that a battery of many hundred volts would be required to produce a current sufficient to actuate the telephone. The use of such high voltages is, however, impracticable. One uses, therefore, cells which strike a mean between the two opposed conditions, and have a relatively small surface while retaining a relatively low resistance.

The cell must be illuminated over its entire surface by light which is as nearly perpendicular to it as possible. It is a great mistake to illuminate only a part of the sensitive surface with the undulating light, as in this case the unilluminated part forms a mere dead weight on the illuminated and active part, so that the current variations are seriously diminished.

While the author commenced his researches with cylindrical cells of 50 mm. length and 18 mm. diameter, he later employed those of 25 mm., and finally of 12.5 mm. length. For many experiments cells of similar length but of only 9 mm. diameter proved very suitable after a method had been found of constructing these with a sufficiently low resistance. In practical experiments cells of the third type were almost exclusively used. The resistance of these cells in the dark should not be more than 25,000 ohms. Flat

cells work best when the diameter of the selenium plate is about 25 to 30 mm.

While in the method of construction used by the author the cylindrical cells are shielded from the influence of the atmosphere by their position inside an evacuated glass tube, the flat cells must be protected in some other way; if used in the open air, a metal capsule with a glass window in it may, for instance, be used. With the high voltages used in connection with the cells the least deposit of moisture from the air causes short circuits and electrolytic actions, which soon destroy the cell.

Having discussed in the foregoing paragraphs the best size and shape of cell, we must now take into consideration their essential properties. The value of a cell depends not only on its sensibility to variations in illumination, but in great measure on the rapidity with which its resistance alters. Thus cells for use in light-telephony must have very little inertia. These conditions may be attained to a certain extent by proper construction and preparation of the cells. For instance, the sensitive layer must be as thin as possible in order that all the active material may be exposed to the action of light. If thick layers of selenium were used the resistance of only the uppermost skin would be reduced by the illumination, since crystalline selenium is almost perfectly opaque. The sensibility of the cell is different at different points on its characteristic curve, *i.e.*, on the curve showing the relation of resistance to illumination. The amount of the variation due to any slight change of illumination is thus dependent on the total intensity of the illumination as well as on the amount of its alteration. As a rule, the illumination is too weak in practical working to do any harm, and at the same time it must be remembered that illumination reduces the resistance, and is therefore in this sense beneficial. The two actions thus compensate one another to some extent. Under certain circumstances the desired result may be obtained by using a cell with a known and suitable characteristic. There are

then so-called "weak" cells, which are more sensitive when faintly illuminated than in a bright light, and also cells, usually called "hard," which give better results when strongly illuminated. In general, however, the former type is most useful since it is as a rule more sensitive than the latter.

At first sight one would think that by raising the voltage applied to the cell the variations of current would also be increased, at least so long as the current was not so great as to damage the cell. It has been found, however, that though carefully constructed cells in which the distance between the electrodes is made as uniform as possible may be driven pretty hard before they are burnt through, there is in every case a best illumination and a best working current, and that only under these conditions does one get the maximum oscillations. If the current is increased beyond this by raising the voltage, the useful action decreases. The theory of this experimental result has not yet been made clear. It is probably to be attributed to the Joulean heat, since heating of the sensitive layer appreciably reduces the sensibility of the cell. For this reason it is advisable, in experiments at short distances, to filter off the heat rays which radiate from the transmitter. At greater distances (1,000 metres and more) this precaution is unnecessary, as the atmospheric absorption is so great that no special apparatus is required.

CHAPTER VI.

BEST WORKING CONDITIONS FOR LIGHT-TELEPHONY.

FINALLY we must go into some points which are of essential importance in the attainment of satisfactory working.

Best Colour of Light.—We know that the light which radiates from the positive crater consists of undulations. Which wave-length, then, of this white light is it that is mainly the cause of the action? The author has made many researches in this direction and has found that, most unexpectedly, the ultra-red and red, and the violet and ultra-violet rays are of most importance. It is therefore advantageous to employ selenium cells which react most definitely with the corresponding wave-lengths. This may be effected, as the author has shown, by the use of sensitisers, without which the maximum sensibility of selenium is to the yellow part of the spectrum. A similar artifice has long since been applied to the preparation of photographic plates.*

Practical experience has shown that at great distances there is no advantage in using cells which are specially sensitive to waves of short length, as the atmospheric absorption is so great those which reach the receiver are of

* See also J. S. Dow, *Electric Review*, London, lix., p. 729, 1906. The absorption of the light as it passes to and fro through the glass of the searchlight reflector, and also through the glass tube of the selenium cell, plays a certain part in the phenomena.

very small intensity ; it is all the more important, therefore, to increase the sensibility for longer waves, on the one hand because it is the red rays which vary most in the transmitter, and on the other because it is these which are least absorbed of all the visible rays by the atmosphere. To this latter circumstance we must attribute the fact that at great distances the light of a searchlight appears to be distinctly red.

It might be thought that the conditions would be improved by using carbons chemically prepared to give a red light in the searchlight. This is not, however, the case, as the materials added only colour the arc itself and make no essential difference in the spectrum of the positive crater, which is the only source of light employed in a searchlight. Indeed it is no consequence, when using cells which have been sensitised for red light, whether the light from the searchlight is used directly or through a colour filter.

Monochromatic Cells.—Selenium cells which are sensitive to different colours also make it possible to transmit several conversations over one beam of light. If several searchlights are placed near one another at the sending station, each being provided with a light filter of different colour, their beams will blend in the atmosphere, and if the colours have been properly chosen will produce a ray of white light. At the receiving station the light will therefore appear to be radiating from a single uncoloured searchlight.

If, now, each searchlight is separately acted on (in the case of their having a common source of current supply it is necessary to take means to prevent the oscillations from spreading from one lamp to another), conversations transmitted simultaneously from the sending station may again be separated at the receiving station if a number of corresponding receivers be used, each of which is sensitive only to one of the colours transmitted. If an ordinary selenium cell were used a confusion of all the voices would be heard at once.

Another application of the colour-sensitive cells consists in the author's method of preventing conversations being overheard by others than those directly concerned. It may first be remarked that of course it is impossible to do this in any case unless the receiving apparatus is placed in the actual beam of light from the searchlight.

Secret Communications.—The method for ensuring secrecy depends on the following principle. Since the transmission of speech is only through *variations* of light, it is of no consequence whether positive alterations (increases) or negative alterations (decreases) are employed, and similarly the effect is the same in photo-phonographic reproductions, whether one uses the original negative film or a positive print taken from it. Now the arc lamp will give the one or the other effect according to the relative direction of the microphone current and the supply current.

If one now employs as transmitter two searchlights controlled by the same microphone, which is arranged to produce positive variations in one arc and negative in the other, and allows their beams to mingle, it is clear that, since the variations are equal and opposite, the total effect on the receiver will be nil. By placing complementarily coloured light filters in front of searchlights the two beams will still, when mixed, produce an ordinary white which will be without effect on an ordinary cell, but if a cell which is sensitive only to the light given out by one or the other of the searchlights be used it will respond at once. By using two receivers their actions may be superposed in the same direction on a telephone common to both circuits. Only the person called, who knows the exact wave-length used, can hear the voice in undiminished loudness, while no one else, in spite of the fact that his selenium cell may be illuminated, can receive anything.

Uses of Light-Telephony.—In conclusion, we must say a few words on the practical importance of light-

telephony. In the first place, there is its use in the navy, where communications may be kept up by its means between ships, whether lying in harbour or in motion. And since their ordinary searchlights may easily be adapted to this purpose, the cost of installing the apparatus is small.

Light-telephony is also very suitable for communication between lighthouses and ships.

Even in the army, for communication between outposts and headquarters, or between besieged fortresses and the relieving armies, its use appears possible.*

Finally, light-telephony appears to be a most useful substitute for the heliograph, with which the rate of transmission does not exceed 200 words per hour.

Light-telephony possesses all the advantages and disadvantages common to every directed method for the transmission of news.

It has one important advantage, namely, that no one can read a message unless the beam of the searchlight is actually directed towards him, and then only with a proper apparatus. We have shown that there are other ways in which secrecy may be maintained.

It is, of course, impossible to read directly from the vibration of the beam of light, as its motions, corresponding as they do to waves of sound, are far too rapid for the eye to follow even if they were otherwise readable, which they are not, as they only resemble a phonographic tracing.

As a disadvantage must be noted the fact that the distance of transmission is limited by the curvature of the earth, though in actual working this is not of great consequence since this form of telephony is particularly suitable for small distances, where a simple and rapid method of communication is required. At greater distances telegraphy takes the place of telephony, as in transmission over the wires.

* As for instance when General Buller got into communication with Ladysmith during the Boer War by means of the heliograph.

We must further consider those questions of light and shade which concern the transmission of speech by means of light. On the one hand, the use of visible rays makes the determination of the proper positions of the sender and receiver easy; but on the other hand, this very visibility of the beam of light is a disadvantage at night, especially for military purposes, since an enemy can at once observe the positions of the transmitting and receiving stations.

A further disadvantage, which is particularly obvious in transmission over great distances, is the absorption of the short-waved visible light by the atmosphere, especially during fog.

Ultra-Red Rays.—These latter difficulties may, however, be considerably reduced by the use of the invisible ultra-red rays which are of greater wave-length. Experiments with these have already given great promise. A selenium cell, bolometer, or thermopile may be used as receiver, while in the beam of light from the sender a thin plate of ebonite is interposed which allows the longer waves to pass in almost undiminished intensity, though completely absorbing the visible rays—a fact observed some time ago by the author.*

By the use of such a filter transmission may be maintained although the beam connecting the sender and receiver is rendered quite invisible. A demonstration of this method was given by the author at the Exhibition of Electrical Novelties of the Electrical Society of Berlin on 19th March 1902.† The system has not yet been tried at great distances.

Putting together all that has so far been said, we find that we possess in electric light-telephony a convenient,

* See also lecture by Perry, "On the Future Development of Electrotechnics," Society of Arts, London, 24th March 1880.

† See *E. T. Z.*, xxiii., p. 643, 1902, and *Mechaniker*, x., p. 66, 1902.

secret, and certain method of communicating up to distances of about 6 to 8 km., at which distances only the thickest smoke or fog can render it uncertain.

Ultra-Violet Rays.—In connection with telephony by means of light and heat rays we may mention Sella's system, in which ultra-violet rays are employed for the transmission of speech. This form of wireless telephony is very like Zickler's electric light telegraph,* and depends on Heinrich Hertz's observation that the sparking distance between two electrodes is increased when ultra-violet light falls on the negative conductor.† If, for instance, the spherical electrodes of an induction coil be separated so far that the induced potential is no longer able to cause a spark, sparking will recommence if a beam of light rich in ultra-violet rays be allowed to fall on the negative electrode. This phenomenon is still more marked if the discharge takes place in rarefied gases. The containing walls of the vessel in which spark takes place must, of course, be transparent to ultra-violet rays. Ordinary glass is not suitable for this purpose. Zickler used a platinum plate and metal ball in a glass vessel, one side of which consisted of a plate of quartz (see Fig. 61). The plane electrode is turned at an angle of 45 deg. to the axis of the vessel, so that the active electrode may be illuminated by the rays entering through the quartz. The best air pressure was found to be about 200 mm. of mercury. In front of the tube is placed an adjustable quartz lens in order that the rays from the transmitter may be concentrated on the cathode. Sella employed a receiver of this

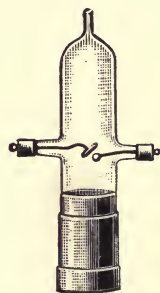

FIG. 61.
Vacuum
Discharger.

* K. Zickler, *E.T.Z.*, xix., pp. 474, 487, and 826, 1898.

† H. Hertz, *Wied. Ann.*, xxxi., p. 983, 1887; Wiedemann and Ebert, *Wied. Ann.*, xxxiii., p. 241, 1887; xxxv., p. 209, 1888.

sort in conjunction with a telephone for wireless telephony. To supply the tube with high tension direct current, an electrical machine may be used. As transmitter, one of the photophonic arrangements described above may be employed. The periodic variations in the illumination of the cathode are thus reproduced in the telephone as sound waves. Dussaud has shown that instead of the tube a fluorescent body placed near a selenium cell may be used. Under the influence of the ultra-violet rays the fluorescent plate gives off rays of light which act on the selenium cell, and hence the sound waves may be reproduced in a telephone connected to the latter.

It is hardly to be expected that these systems due to Sella and Dussaud will attain to practical use, since the absorption of ultra-violet light is so great even in clear weather.

Let us now turn to wireless telephony by means of electric forces, and in the first place to hydro-telephony, in which the transmission is effected by currents in the earth or sea.

PART II.

WIRELESS TELEPHONY BY MEANS OF ELECTRICAL FORCES.

CHAPTER VII.

CLOSED CIRCUIT TELEPHONY.

Closed Circuit System.—The spreading out of the current between two electrodes placed on an unlimited conductor is the physical foundation of these methods. In Fig. 62 are shown the stream lines of the current between two electrodes, A and B, placed in water or damp earth. As one sees, the lines do not go straight from one electrode to the other, but spread themselves out in curves through the entire conducting medium. Those in the neighbourhood of the straight line between the stations lie close together, while further out the density of the lines is less. If two earth plates be connected by an insulated wire at points reached by the current a proportion of the latter will pass from one to the other by the wire, and the greater the conductivity of the wire the greater will be the current which it carries. In this way a certain fraction of the energy sent out by the transmitting station is picked up, and actuates the receiver. The two stations thus form what is in some respects a single circuit.*

* See J. Erskine-Murray, "Handbook of Wireless Telegraphy," p. 2, London, 1907.



The two earth plates should be placed on the same stream line, the most favourable position being when the receiving and sending conductors are parallel.

If the earth plates are placed so that the receiving wire is perpendicular to the stream lines of the current, and therefore

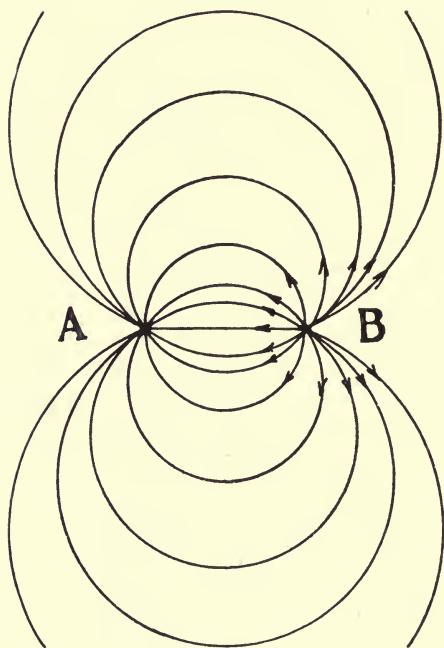

FIG. 62.

Lines of Flow between Two Electrodes.

has its ends on the same equipotential surface, transmission will not be possible, as no current will flow through the wire.

A transmitter for wireless telephony on this principle, therefore, consists essentially in an arrangement for producing oscillatory currents corresponding to the waves of sound, and for conducting these currents to two plates in the earth or sea.

The receiver consists of two plates similarly oriented to the first pair, which are connected by an insulated wire through a telephone (Fig. 63).

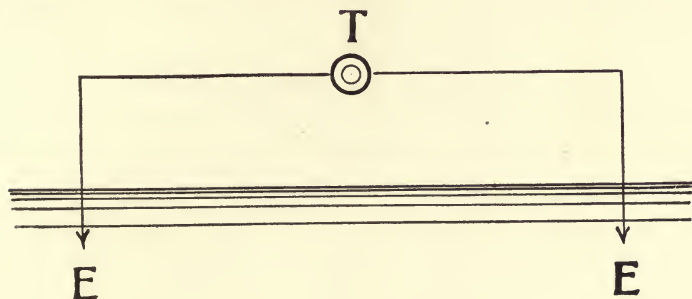

FIG. 63.
Receiving Circuit for Closed Circuit System.

In order to make the total resistance as low as possible it is best to use a low resistance telephone.

Experiments made, so far, on this method, differ only in regard to the transmitting apparatus.

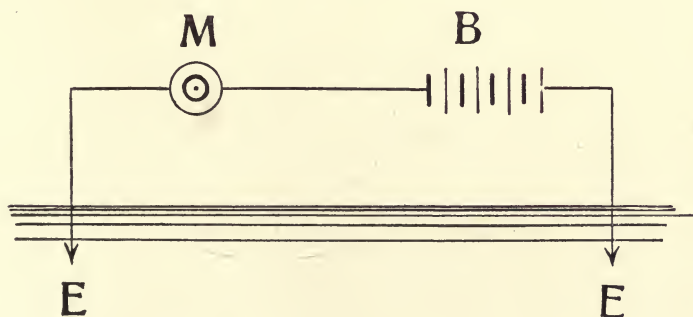

FIG. 64.
Transmitting Circuit for Closed Circuit System.

The simplest of these is shown in Fig. 64. In place of the direct connection of the microphone to the earth plates a transformer may be used (Fig. 65).

Attempts were made by Ducretet in 1902 to telephone over land by this method. He shows experimentally what had already been deduced theoretically, namely, that the greater the distance between the stations, the greater must be the distance between the earth plates, and that the latter also depends on the nature of the soil.* Using a base line of 60 metres, Ducretet transmitted speech over a distance of 1,000 metres.

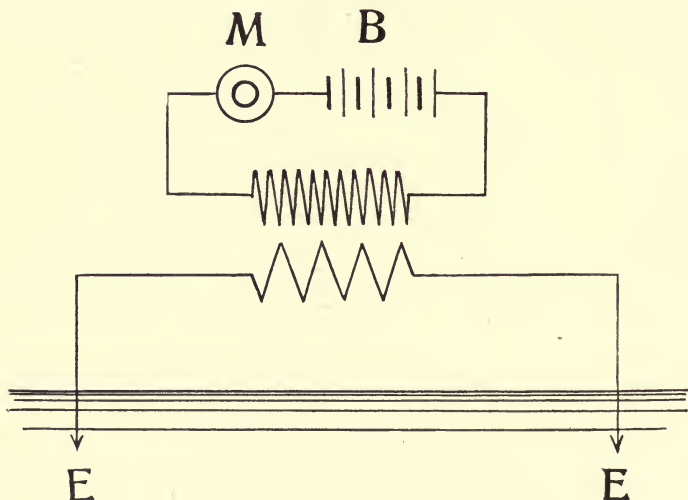

FIG. 65.

Transmitter for Closed Circuit System.

The experiments carried out by L. Maiche since 1900 at Castle Marçais on the Marengo estate of the Prince of Monaco are on the same principle. A base of 20 metres is found to be sufficient for a range of 400 metres. The limit of transmission of telephonic speech was at first given

* *Comptes Rendus*, B. 134, p. 92, 1902; *Electrician*, xxiii., p. 67, 1902; and *Rev. Ind.*, xxxiii., p. 34, 1902. See also Gavey and Preece's experiments, p. 89 below.

as 4 km., but later news is to the effect that a distance of 7 km. has been reached with a base of 450 metres.*

Finally we may mention the experiments of Armstrong and Orling † (1902), of the author (1902), and of Engisch ‡ (1904).

The Author's Experiments.—The author attempted to use this system during his experiments in light-telephony on the Wannsee, to provide a means of communicating back from the boat to the shore, but the short base available on board the boat, and the necessity for keeping it end-on to the shore station when moving the boat from place to place, rendered the working unsatisfactory.

In order to attain to a considerable range, either the distance between the earth plates must be very large, or the energy sent out by the microphone current must be much increased.

In place of an ordinary granular carbon microphone a so-called heavy current microphone may be employed which carries a more powerful current, or an arc may be used as transmitter, either by speaking directly to it (see Fig. 28), or by connecting it to a microphone § (Fig. 66).

Actual experiments with these improved transmitters have, however, given no better results than those with the simpler apparatus described above.

* *Electrical Review*, London, l., No. 1263, 1902; also German patent, No. 134,996, of 22nd August 1901. See "Für alle Welt," p. 373, 1902.

† *Electrical World and Engineer*, xlvi., p. 1122, 1905.

‡ Further information in Zacharias u. Heinicke, "Prakt. Handbuch der drahtlosen Telegraphie und Telephonie," Vienna and Leipzig, 1907, pp. 219-221.

§ Richard von Horwarth, Sigmund Musits, and Dr Stefan Hagyi Ristic, Austrian patent. See also American patent, No. 777,216 of 24th November 1902. A. F. Collins, *Western Electrician*, xxxviii., p. 292, 1906; and *E.T.Z.*, xxvii, p. 1073, 1906. H. Mosler, *E.T.Z.*, xxvi., p. 490, 1905.

Open Circuit Systems.—Finally we must mention Mosler's system in which earth conduction is also used, but differs from the others in that large variations of the voltage and small currents are employed in place of large currents and small voltages.

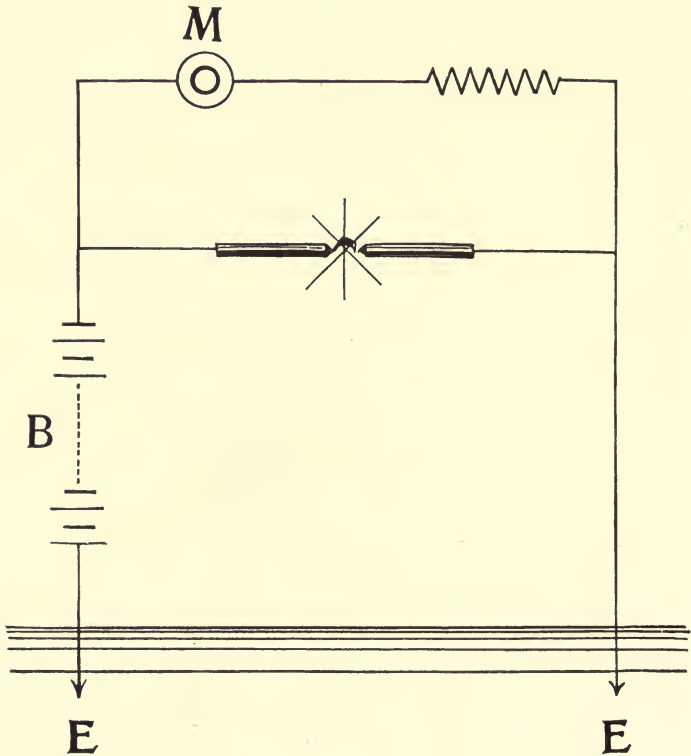

FIG. 66.
Arc Transmitter for Closed Circuit System.

The transmitting apparatus is shown in Fig. 67.

The oscillatory microphone currents are brought to a high voltage by means of a transformer, only one pole of which is earthed, the other remaining disconnected. At

the receiving station, a telephone earthed on one side only is employed. The telephone has a metallic cover which is touched by the observer when listening.*

The use of an aerial wire at the receiving station proved of no advantage. Some increase in the loudness of transmitted speech took place, however, when the free end of the wire was held in the hand.

The transmission could be further improved by attaching a bobbin of copper wire to the free end of the secondary. If both poles of the induction coil were earthed the transmission was very much weakened, though under certain circumstances it was possible to obtain good transmission when both ends of the telephone at the receiving station were earthed. If A in Fig. 68 represents the earth plate at the transmitting station, and B, C, D the earth plates at the receiving station, T the telephone, and E a switch by means of which either of the earth plates C or D may be connected to the telephone, it is found that there is practically no transmission if the plates B and C are connected to the telephone.

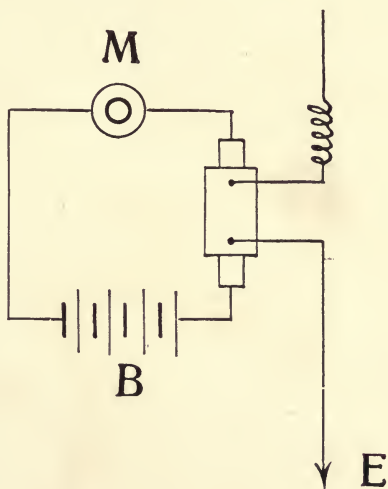

FIG. 67.
Open Circuit Direct Transmitter.

Mosler concluded from this that the high tension microphone current which flows into the earth by the plate A

* Mosler's apparatus is somewhat similar to Dolbear's, American patent, dated 1882. (See Erskine-Murray, "Handbook of Wireless Telegraphy," p. 34, London, 1907, also p. 92 below.)

causes rhythmical electrifications of the earth which spread out with decreasing intensity.

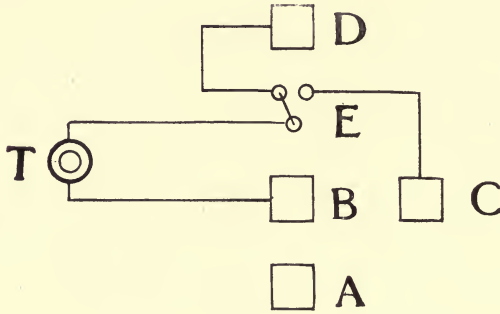

FIG. 68.

Proof of Radial Flow with Open Circuit Transmitter.

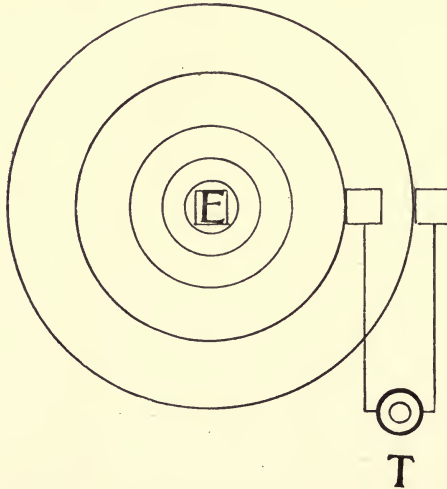

FIG. 69.

Closed Circuit Receiver with Open Transmitter.

Limits of Closed Circuit Systems.—Transmission of speech can only be obtained when points at different

potentials, *i.e.*, at different distances from the sending station, are connected through the telephone, since in this case only does a current flow through it (Fig. 69). Transmission of speech without a second earth plate was obtained by earthing the telephone by holding the metal cover in the hand. The earth plate was fortunately so placed that it was possible to obtain an extensive variation of the distance in radial directions. Later experiments showed that it was not impossible to achieve transmission over several kilometres, especially over water, if larger transformers and microphones which could stand heavier currents were employed. Mosler himself, however, declares his system does not provide a solution of the problem of wireless telephony at great distances. Hydro-telephony can thus hardly be said to have attained to practical importance.

CHAPTER VIII.

ELECTRO-MAGNETIC INDUCTION TELEPHONY.

IN this the transmission is by means of electro-magnetic or electro-static induction. In the first of these methods the varying magnetic induction is caused by the variations of the microphone current, while in the second case variations in the electric charges are the cause of the action.

According to recent Maxwellian theory there is no difference between an electrical force of electro-magnetic origin and an electrical force of electro-static origin.

The simplest case of induction telephony is cross talk in a telephone system, *i.e.*, when words spoken on one wire are heard on a telephone attached to a parallel but separate line.

Trowbridge, of Harvard University, was the first to examine this phenomenon systematically.

In his experiments he employed two coils consisting of many turns of insulated wire (Fig. 70).

In the transmitting circuit were a microphone and battery, and in the receiving circuit a telephone. In the latter circuit the induced currents cause motions of the telephone diaphragm in unison with the sound waves which actuate the microphone of the transmitter. Transmission can only be obtained at relatively short distances by this method. Since the oscillatory currents in the microphone circuit are limited by the carrying capacity of the microphone, the transformers required in order to obtain transmission over considerable distances would have to be

of impracticable dimensions. The method is on this account of no practical importance.*

We may here briefly describe the experiments of M. R. Hutchison at the St Louis Exhibition.

The transmitting circuit consisted of a large wire cable in series with a battery and microphone. The portable receiver was a coil of 30 cm. diameter wire in several layers, with two telephones in series (Fig. 71).

The distance to which speech was transmissible with this apparatus was naturally small.†

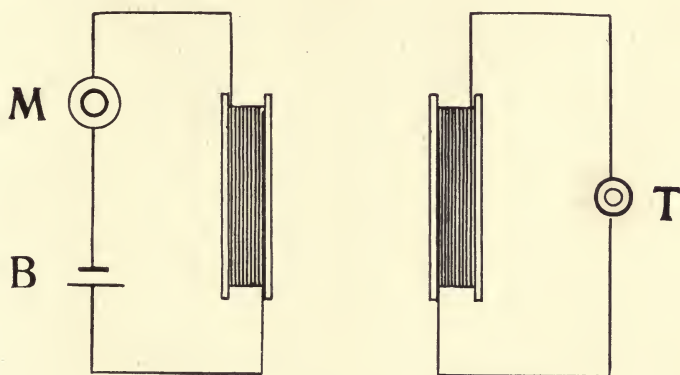

FIG. 70.

Electro-Magnetic Induction Telephony.

Gavey and Preece.—The experiments and work of Gavey and Preece, which commenced as far back as 1894, have given more satisfactory results ‡

Gavey's first experiments were across Loch Ness, in the Scottish Highlands.§

* E. Wilson and C. J. Evans used the larger current of an arc influenced acoustically or magnetically, instead of the weaker microphone current. *The Electrician*, xlvi, p. 46, 1901.

† See also L. Maiche, French patent, No. 376,100.

‡ *E.T.Z.*, xxi, p. 812, 1900.

§ British Association Report, 1894.

With an average distance of 2.1 km. between them, two wires were suspended parallel to one another on opposite sides of the loch, and their ends well earthed. The length of each was about 6.5 km., and their average distance apart 2.1 km. In series with the sending conductor was placed a Deckert's microphone and a battery giving 14 volts. A tele-



FIG. 71.

Hutchison's Experiments.

phone was placed in the receiving circuit. Words spoken into the microphone were audibly repeated by the telephone.

That better results were obtained in this experiment than in those previously described may safely be attributed to the fact that in addition to the induction between the circuits the earth currents were by no means negligible. This method, therefore, depends on a combination of hydro and induction telephony.

Preece in 1899 carried out further experiments of a like nature across the Menai Straits, an arm of the sea lying between the counties of Anglesey and Carnarvon, and found that the reception was best when the earth plates at the ends of the parallel wires were sunk in the sea, *i.e.*, that under these circumstances it was possible to make a considerable reduction in the length of the wires without hindering the transmission.

Skerries.—A practical use for this means of communication was soon found in the establishment of a telephonic connection with the lighthouse on the Skerries, a rocky island off the coast of Anglesey, where the roughness of the sea bottom and the strength of the tidal currents rendered the use of a cable impossible. The distance from the land station at Cemlin was about 4.5 km.

The installation consists of a wire about 700 metres long on the island, and a parallel wire of about 5.7 km. on Anglesey. The ends of both wires were attached to plates sunk in the sea. Transmission proved so good that the installation is still in operation.

Rathlin.—Shortly afterwards Gavey connected the island of Rathlin with the north coast of Ireland by means of a similar installation, the distance in this case being 13 km. The conductor on the island was 2 km. long, and that on the mainland 9 km.

Attempts have also been made to establish communication between ships, and from ship to shore, by this means, in which case the conductor was carried along the length of the ship at the height of the topmasts, and was connected to plates in the sea.

A more extensive use of this system is, however, as little to be expected as is that of hydro-telephony,—the chief objection being the necessity for very long parallel wires, whose length, indeed, must be such as would nearly serve to bridge the actual distance between them.

It is very probable that the experiments of Valle and Plisner at Trieste, about which some notices appeared a few months ago, are of a similar nature, though as yet no details have been given.

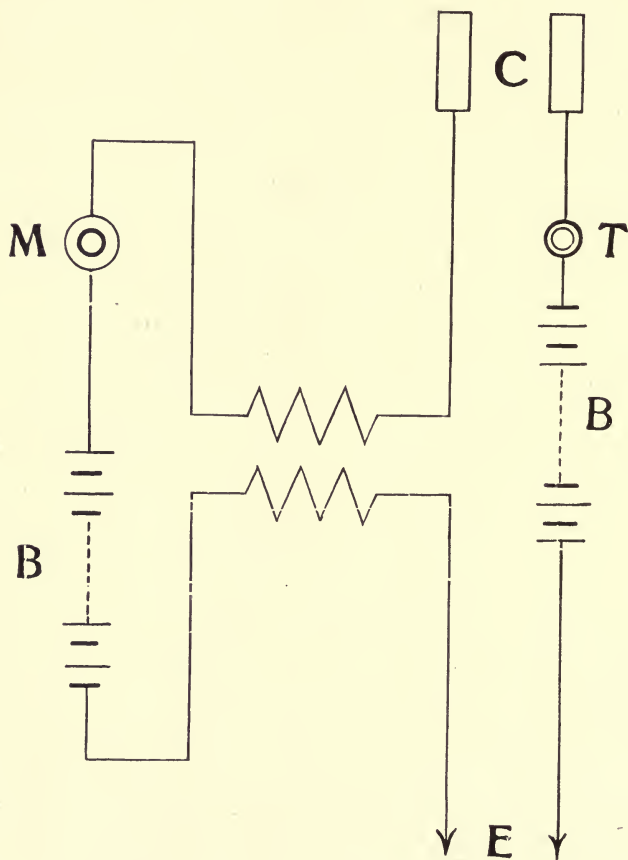

FIG. 72.

Dolbear's Open Circuit System.

In conclusion, we shall describe some arrangements which depend on electro-static induction.

Dolbear.—A. E. Dolbear utilised the charge on a capacity area, such as a gilded kite at the top of an aerial wire, which was varied by means of a microphone—the variations corresponding to the sound waves spoken into

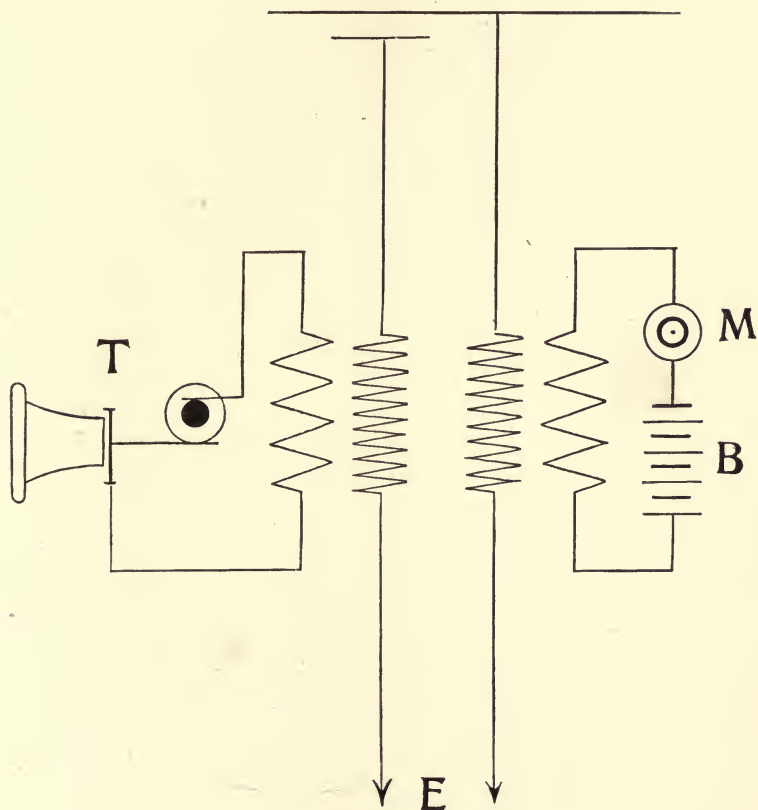

FIG. 73.

Edison's Railway Wireless Telephone.

the latter. For this purpose the capacity C was suspended at a suitable height above the ground, and was connected to a transformer and to a battery of 100 volts or more, the other terminal to the battery being earthed (Fig. 72).

At the receiving station a similar capacity area was elevated and connected, through a telephone, to earth.

The oscillations of potential in the transmitter disturb the electrical equilibrium of the receiver, and are rendered audible by the telephone.

The two capacity areas form what is practically a condenser. In order to increase the action the receiving capacity may be kept oppositely charged to the transmitter by means of a battery.

Edison.—A similar system of wireless telephony, which has been used in communicating to moving railway trains, was designed by Edison (Fig. 73). In this case one of the capacity areas of Dolbear's system was replaced by a wire supported on poles alongside the line, while the other was represented by the metal roof of the railway carriage which was connected to earth through a transformer and the wheels of the car.

As receiver Edison used his electro-motograph telephone, which depends on the variations in current due to the alterations in friction between a rotating cylinder of wet chalk and a palladium point attached to a membrane.

Collins.—From the somewhat incomplete notices which have recently appeared, it seems that A. F. Collins has carried out experiments of a similar nature.*

Collins used a microphone, which was placed in series with the primary of a transformer and a microphone, one end of the secondary of which was earthed, and the other connected to an aerial wire. A Leyden jar was placed in parallel with the terminals of the transformer. The receiver consisted of a similar aerial wire, earthed through a transformer, while the other winding was connected to a tele-

* A. F. Collins, *Electrical Review*, New York, xli., p. 742, 1902; *Electrical World*, xxxix., p. 584, 1902, and xli., p. 1046, 1903; *Scientific American*, lxxxvii., p. 37, 1902.

phone. Collins states that long electric waves were produced in the aerial of the transmitter, and were propagated outwards through earth or water.

Collins' experiments were commenced in the end of 1899. In 1900 the distance attained was about 60 metres ; later on, at Lake Rockland in New York State, this was extended to about 5 km.

According to notices in the American papers, Collins has recently carried out further experiments in the North, between Jersey City and New York.

Conversation was kept up between ships at a distance of from 150 to 180 metres.

Although no practical results worth mentioning have been attained with either earthed or unearthed electro-static induction methods, they are interesting on account of the employment of earthed aerial wires connected to capacity areas which play so important a part in the methods of wave-telephony described in the following section.

CHAPTER IX.

SPARK-TELEPHONY.

Imperfect Methods.— Soon after the publication of Marconi's first experiments on telegraphy without wires by means of electric waves, attempts were commenced on

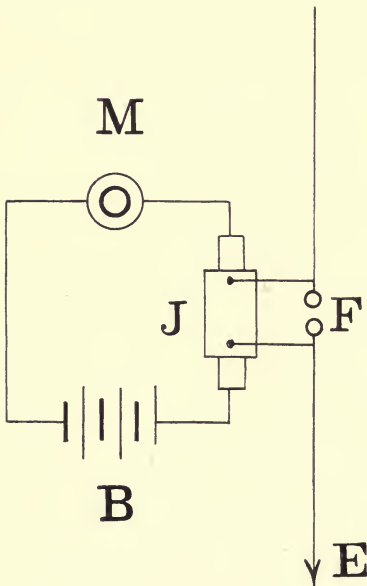

FIG. 74.
Spark Telephone Transmitter.

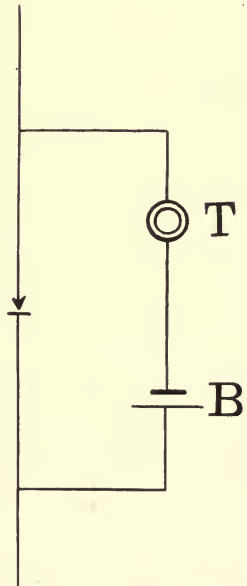

FIG. 75.
Coherer Telephone Receiver.

all sides to devise a system of wave-telephony based on the same principles. These essays consisted at first in merely substituting a microphone for the interrupter on the coil

of the transmitting station (Fig. 74). The idea was that on speaking into the microphone the current induced in the transformer would cause a spark at the spark gap in the aerial, producing oscillatory currents which would transmit speech to a distance.

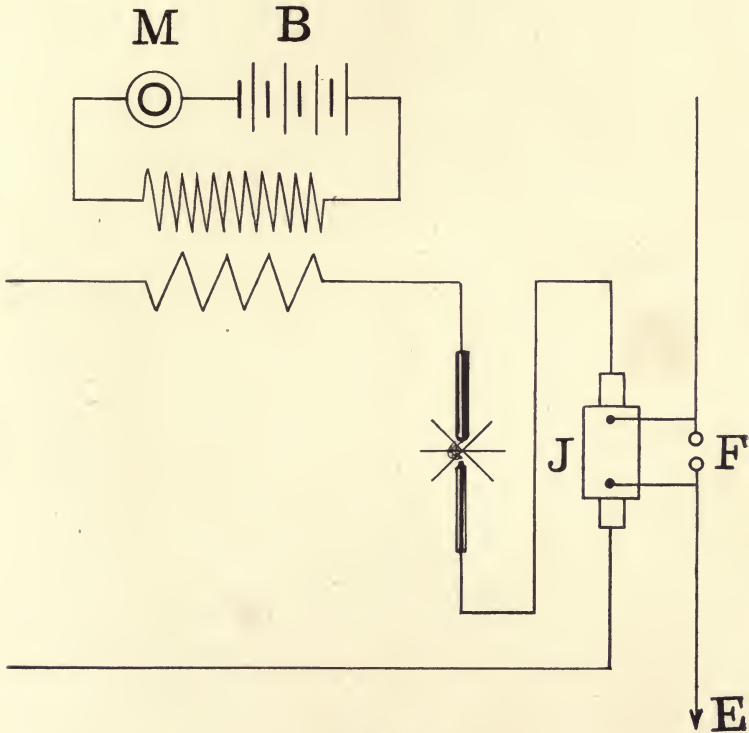

FIG. 76.
Series Arc and Spark Transmitter.

Any type of receiver could be used which was suitable for telephonic reception of wireless telegraph signals, for instance, a self-decohering coherer, microphonic contact, electrolytic detector, or magnetic detector.

Numerous and often extremely complicated variations of this simple transmitter are to be found in American and

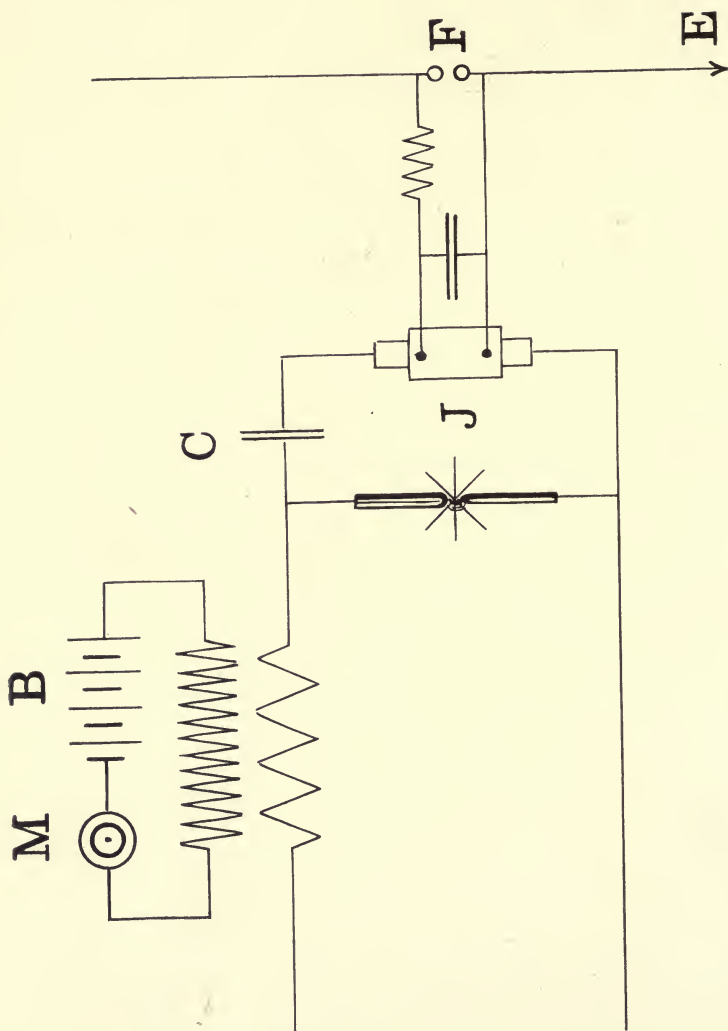

FIG. 77.—Shunt Arc and Spark Transmitter.

English patents and journals.* These improvements are mostly concerned with the construction and arrangement of the microphone, and the development of the secondary oscillating circuit corresponding to that used in wireless telegraphs. As examples may be taken Marconi's arrangement with open oscillatory circuit, and Braun's with a closed jig circuit coupled to the aerial.† A frequently recurring modification is the replacement of the microphone by an arc lamp in order that more energy may be transformed in the induction coil circuit.‡ Some transmitters of this type are shown in Figs. 76-78. Fig. 76 represents Simon's arrangement of the speaking arc. Somewhat similar connections are shown in Fig. 77, except that the speaking arc is placed in parallel with the primary of the transformer instead of in series. In this shunt circuit a condenser is placed to prevent the continuous current traversing it. In Fig. 78 an arrangement is shown which is based on Duddell's speaking arc connections.§ In both of the latter systems the aerial is excited by a closed jig circuit, unlike the simpler Marconi transmitter, which is the basis of Fig. 76.

We must also notice a method in which the microphonic current acts on the dynamo which supplies current to the induction coil.||

We need not go more thoroughly into the methods of this kind, since, though they are capable of transmitting a

* See also, for instance, F. J. M'Carty, San Francisco, U.S.A., patent C. 14,540, Class 21a, of 19th April 1906; German patent, No. 178,051; and French patent, No. 365,160, of 10th April 1906.

† A short but important summary of these developments was given by H. Th. Simon in the *Phys. Zeitschrift*, iv., p. 364, 1903.

‡ See also H. Weselius, German patent, No. 176,010, of 28th February 1905, in which the variations of current are caused by connecting one carbon of the arc to a membrane which vibrates with the voice; also French patent, No. 4,585, 1906.

§ O. Nussbaumer, *Phys. Zeitschr.*, v., p. 796, 1904.

|| H. Mosler, German patent, M. 26,653, Class 21a 4, of 21st December 1904.

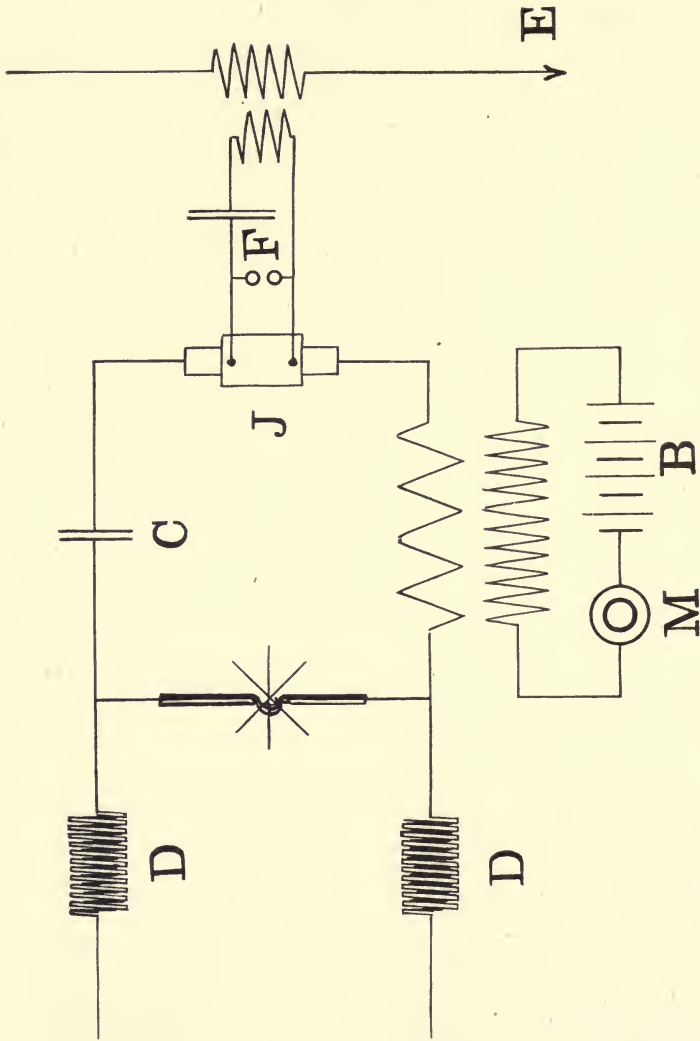

FIG. 78.—The Arc as Interrupter for Spark Circuit.

musical tone, they give an extremely imperfect reproduction of speech. The reason for this is the impossibility of obtaining a sufficiently rapid succession of sparks to give the higher overtones by which the various vowels and consonants are distinguished. A musical note, correspond-

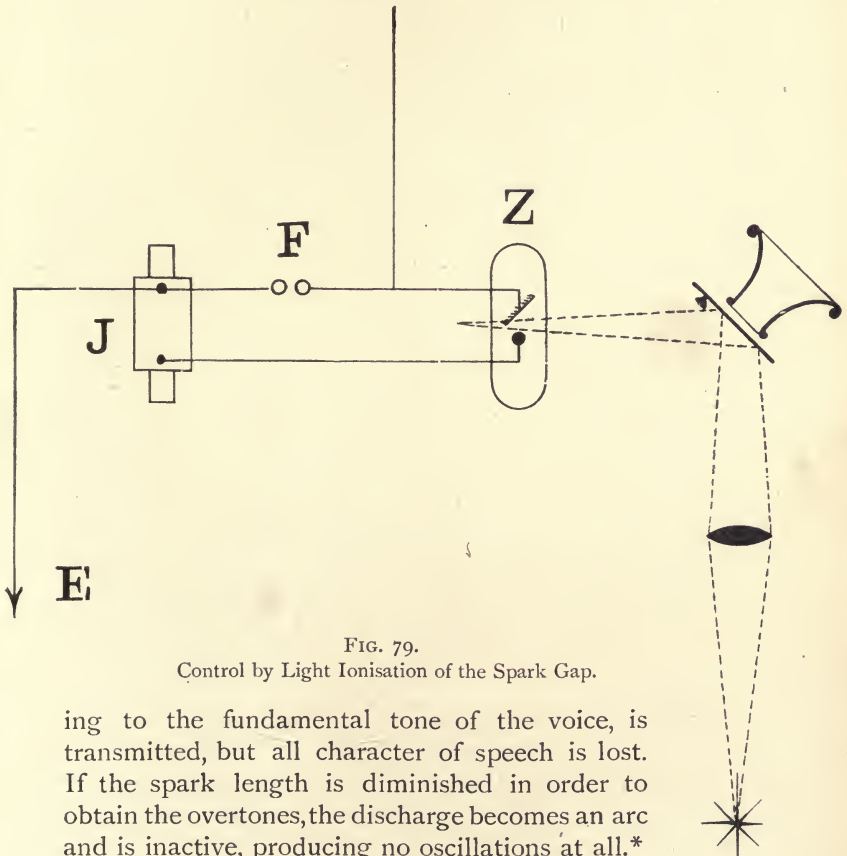

FIG. 79.
Control by Light Ionisation of the Spark Gap.

ing to the fundamental tone of the voice, is transmitted, but all character of speech is lost. If the spark length is diminished in order to obtain the overtones, the discharge becomes an arc and is inactive, producing no oscillations at all.*

Theoretical Desiderata.—The only method of getting

* See also R. Franz and J. Reinart, *E.T.Z.*, xxv., p. 1,083, 1904, and xxvi., p. 65, 1905; also W. Ruppin, *E.T.Z.*, xxvi., p. 19, 1905.

over this difficulty appears to lie in the employment of a source of energy which is completely controlled by the microphone current. This control may exist either in the primary or secondary circuit of the transformer.* An attempt in the latter direction was made by Lonardi in 1897. The sound vibrations were communicated to the

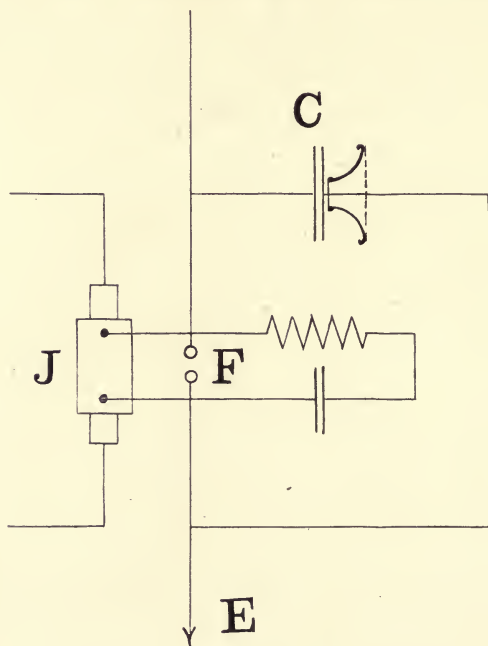

FIG. 80.

Fessenden's Condenser Telephone.

balls of a Righi oscillator which were maintained at a constant difference of potential by means of an electrical machine or otherwise. This method depends on the observation that the intensity of the emitted electrical waves depends on the length of the spark.

* See Brown and Neilson, "Improvements in means of Telegraphing or Telephoning without Wires." British patent, No. 28,955, 1896. Completed 17th December 1896.

A similar experiment belonging to the same class was made by Jan Szczepanik.* Szczepanik used a spark gap of constant length in series with which was a discharge tube sensitive to light, like that used by Zickler in his experiments on wireless telegraphy (Fig. 79). The cathode of this tube was illuminated by a ray of light reflected from a polished membrane on which the waves of sound were concentrated. The resistance of the discharge tube varies with the intensity of the illumination, and the supply current to the oscillator is correspondingly varied, hence the intensity of the emitted electrical waves varies with the waves of sound. Heinicke's recently patented device for the transmission of words and tones belongs to this class, since he influences the spark directly by means of Röntgen or cathode rays which are controlled by the waves of sound.†

Other devices for causing alterations in the intensity of the electrical waves which shall correspond with the sound waves are based on the action of a microphone current on the primary current in the transformer.‡

Fessenden's Converters.—The principle of the second group of methods consists in the variation of the frequency of the electrical oscillations by influencing the capacity or inductance of the oscillating circuit. In Figs. 80 and 81 are shown two arrangements of this kind devised by Fessenden.

In the first of these the capacity of the air wire is altered by the action of the sound waves on a condenser, one plate of which is movable and vibrates in accordance with the motions of the air. In the second, the inductance of the aerial is altered by means of the primary of a transformer

* German patent, No. 138,226, of 9th May 1901.

† H. Heinicke, German patent, Application H, 39,706, Class 21a, 4th January 1907.

‡ See H. Mosler, German patent, M. 26,653, Class 21a 4, of 24th December 1904; also German patent, No. 173,690, of 15th July 1905.

*use
17
1907*

put in series with the aerial, while the secondary is connected to a microphone and battery (Fig. 81).*

Rate of Sparking.—Although speech may doubtless be transmitted by either of the above methods, the want of a proper source of supply for the spark current is the cause of great difficulty. If, for instance, one uses an

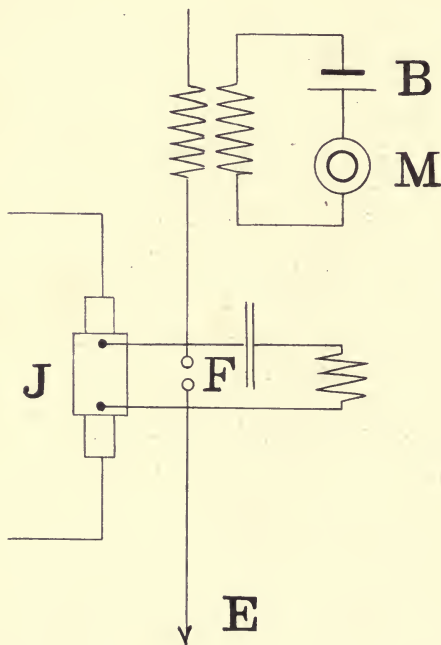

FIG. 81.

Fessenden's Microphone Control.

induction coil with an interrupter only a relatively small number of sparks occur per second, and these consist of intense but rapidly damped oscillations. In order to make the conditions clear we may suppose that a turbine interrupter is used which breaks the primary circuit 100 times per second. Each break causes an oscillatory spark. The pitch of sound given by the series of sparks is therefore 100 per second.

Now, presuming that a frequency of a million per second, such as is common in wireless telegraphy, is used, we should have, if the spark were not damped, 10,000

* See the American patents, No. 706,742, of 6th June 1902, No. 706,747 and 753,863, both of 28th September 1901; and German patent, No. 171,535, of 13th August 1902.

waves for each interruption. Since, however, there is a rapid loss of energy in the circuit through radiation and the production of heat, the current in a spark quickly diminishes and dies out altogether after comparatively few oscillations. This is shown in Fig. 82, which is an oscillogram of the discharge of a condenser taken with a cathode ray oscillograph. In this case the current died out after about twenty oscillations. We therefore get only twenty oscillations instead of 10,000 at each discharge, and the discharge itself lasts only the $\frac{1}{30000}$ of a second. Following it there

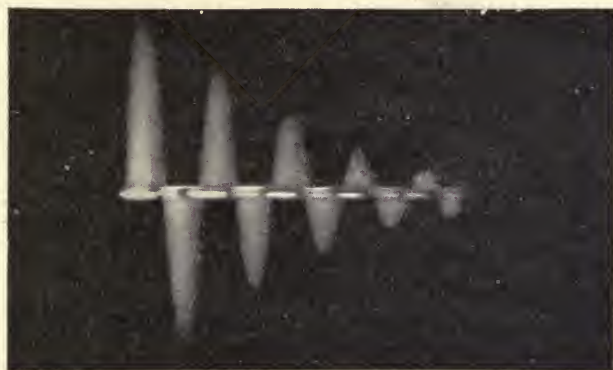

FIG. 82.

Oscillogram of Condenser Discharge.

is a relatively long pause of $\frac{1}{100} - \frac{1}{30000} = \frac{499}{30000}$ second before another discharge commences. Fig. 83 gives a diagrammatic representation of the successive discharges. The distance between them is, however, much shortened in the diagram, as that actually occurring in practice would be fully 500 times as long as the discharge itself. Thus in the figure the interval between the discharges, each represented by a length of 3 cm., would properly be shown as 15 metres.

Since, however, the frequency of the waves of speech may amount to several thousand per second, it is clear

that a series of interrupted electrical oscillations in which the pauses may be as long as $\frac{1}{100}$ of a second is entirely unsuited to the transmission of speech. For this purpose the individual discharges must follow one another very much more rapidly; the aerial must thus be excited by a succession of sparks following one another so rapidly as

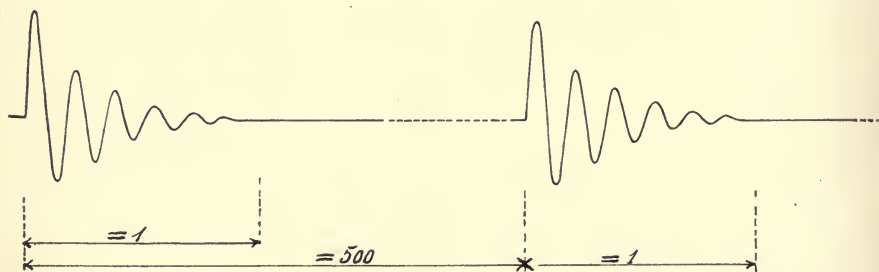

FIG. 83.
Damped Wave Trains.

to give a note which is at least as high in pitch as the highest overtones of the human voice, *i.e.*, from three to four thousand per second.*

In order to minimise the sound caused by the succession of sparks the rapidity must be further increased, so that the spark frequency rises beyond the limits of audibility.

* The highest audible tone has a frequency of about 33,000 per second, but a pitch of above 4,000 per second is not of common occurrence.

CHAPTER X.

ACCELERATED SPARK RATES.

Majorana's Spark Method.—Q. Majorana carried out, in the Physical Institute of the University of Rome, the first successful experiments in the use of a spark rate of above 10,000 per second.*

Variable Spark Gap.—The conversion of speech into electric surges was in this case by Lonardi's method of a variable spark gap. For this purpose a moving stream of mercury was used as one electrode, the other being fixed. The microphone current acted on the mercury column, bringing it nearer to, or further from, the fixed electrode, thus altering the intensity of the sparks in accordance with the sound waves.

By using a magnetic detector Majorana obtained an intelligible reproduction of the transmitted speech. The transmitting aerial was outside the building of the Physical Institute, while a wire of about 1 metre in length inside the building served as receiving aerial. Majorana believed that by using longer aerials with his apparatus he would be able to transmit speech several kilometres. This arrangement had the disadvantage that after a short time the mercury became so much altered by the discharge that it was no longer fit to use; Majorana, therefore, endeavoured to replace it by a high-tension microphone placed directly between the aerial and the spark gap. Since the intensity

* *Nuovo Cimento*, 1904; *The Electrician*, 7th October 1904; *E.T.Z.*, xxv., p. 943, 1904; *Eclair Electr.*, xliiii., p. 65, 1905.

of the radiation depends on the resistance of the aerial wire, it is clear that it must be altered by the variations of the resistance of the microphone.* Majorana has recently communicated to the Italian Electrotechnical Society a description of his high-tension microphone, and of the results obtained with it.† In this paper he bases his explanation of the action of his hydrodynamic microphone on the principle of the hydraulic telephone. The apparatus consists essentially of an electrically conductive stream of liquid whose movements are influenced by the sounds of speech. The stream falls upon the plane surface of the so-called "collector," which consists of two cylindrical pieces of platinum insulated from one another. On striking the upper surface of the collector, the fluid spreads out over the surface, and connects electrically the two halves of the collector. The jet of fluid is controlled by the action of the voice on a diaphragm forming one side of the tube through which the liquid flows, more or less flowing out in accordance with the waves of sound. The film of liquid connecting the plates of the collector thus varies in thickness, and hence in conductance, and therefore if the plates are connected by proper means to a spark gap, the current will vary simultaneously, producing an electrical vibration corresponding exactly with the sound waves.

Majorana's Rapid Sparking.—Before we leave these researches we must describe more completely the method by which Majorana obtained so high a rate of sparking as 10,000 discharges per second. The only information given on the subject is that the supply current was taken from the town mains (alternating at forty periods per second), and was passed through the primary of a transformer. On superficial consideration it might be supposed that a trans-

* Experiments were recently made (8th April 1907) with this apparatus between the Telegraph Institute and the Wireless Telegraph Station on Monte Mario, in Rome.

† *Elettricista*, pp. 213-215, 1907.

former supplied in this manner would (as in the case of an interrupted unidirectional current) only give eighty sparks per second,* and that the production of 10,000 per second

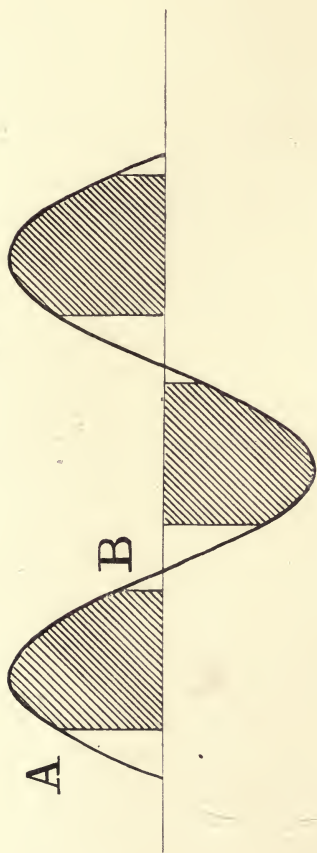

FIG. 84.—Active Portions of Alternate Current Cycle.

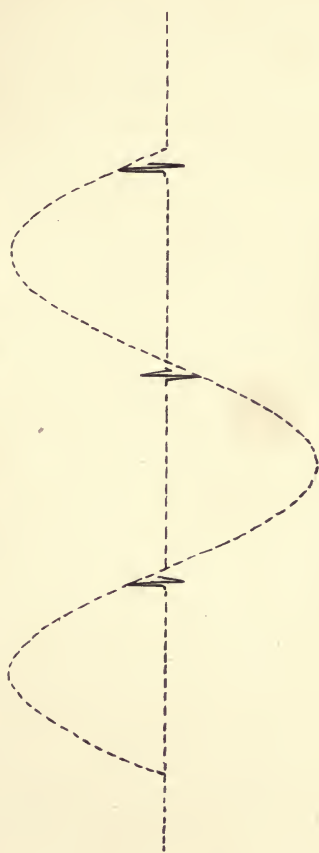

FIG. 85.—Jig produced on Arc breaking.

would require an alternating current of 5,000 periods per

* In the resonance induction coils now used in wireless telegraphy the rate of sparking in the secondary is much greater than that in primary circuit.

second. This is no doubt usually true.* Thus when we examine Fig. 84 we see that the first discharge takes place at the moment when the potential rises sufficiently to cause a spark; a moment which may naturally occur before the secondary voltage has reached its maximum. This point is marked A on the curve, and represents the potential which just causes a discharge across the spark gap. As the supply of energy to the primary continues, this spark becomes an arc, which is extinguished when the induced voltage is no longer sufficient to maintain it. This potential, at the moment when the arc breaks, is represented by the point B on the curve, and is considerably lower than that at which the discharge commenced. In this case, therefore, there is in each alternation a considerable period during which an arc exists. This is represented by the shaded portion of the diagram between A and B. Since there can be no oscillatory discharges while this arc continues, they only occur at the moment when it is broken (B on curve), and as the potential is then low they are not energetic. We see, therefore, that for each alternation of the primary current only one train of waves is produced by the secondary (Fig. 85). If, however, a choking coil of considerable inductance is put in the supply circuit, the conditions are altered, and a large number of secondary discharges may be obtained for every alternation of the primary current, particularly when the discharge voltage is kept relatively low by the use of a short spark gap.† The moment the

* Alternating currents of such frequencies are, of course, most suitable for wireless telephony. Fessenden has recently published the results of his experiments in 1903-04, in which he used an alternating current generator giving 10,000 periods per second (see *Zeitschrift für Schwachstrom Technik*, i., pp. 74 and 93, 1907). Similar attempts to attain a high discharge rate by means of a singing arc will be described later.

† See also the following:—H. Abraham, *Soc. Franc. de Phys.*, 5 Mai 1899, Bulletin, p. 70; A. Blondel, British patent, No. 21,909, of 3rd December 1900; J. Härden, *Phys. Zeitschr.*, iv., p. 461, 1903; also F. J. Koch, *Ann. d. Phys.*, iv., 14, pp. 547-555, 1904.

spark commences (point A on Fig. 86) the total primary voltage comes on the choking coil, and the supply current suddenly falls, and energy is no longer forthcoming for the maintenance of the arc. When the arc has been extinguished the voltage again divides itself between the choking coil

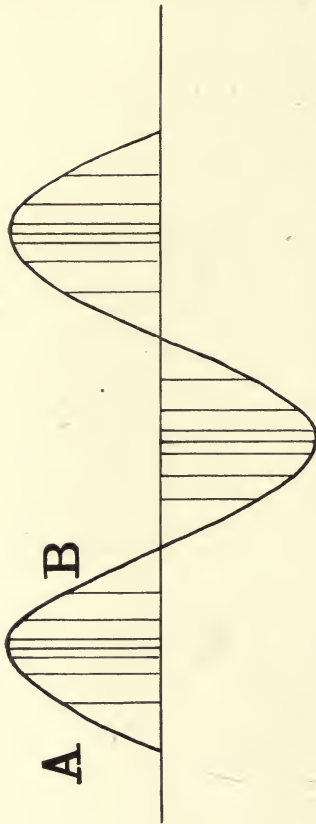

FIG. 86.—Occurrence of Sparks when Large Inductance in Supply Leads.

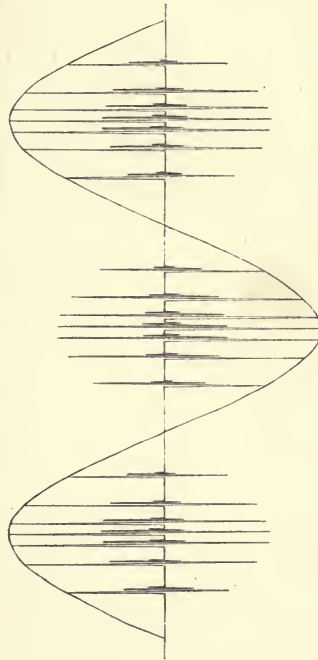

FIG. 87.—Resulting Oscillations when Inductance in Supply Leads.

and the primary of the transformer, and hence, as the primary voltage continues to increase, the induced secondary voltage may again rise sufficiently to cause a spark. The action then repeats itself. The self-induction of the transformer diminishes, the primary current suddenly rises, the

choking coil begins to act and checks the supply of energy so suddenly that the second arc also breaks. Spark after spark thus follows, and all the more rapidly as the primary voltage nears its maximum, but after this has been passed the intervals between them increase until the point B on the curve has been reached, when they leave off until after the commencement of the next alternation. A large number of discharges is therefore obtained at every alternation by aid of the choking coil, every one of which gives a jig suitable for transmission. This is shown in Fig. 87. In Figs. 88 and 89 are given cinematographic pictures of the



FIG. 88.
Spark Groups following one another.

discharges of a large transformer. In these one can see clearly that there are several sparks during each alternation, and that they are more numerous with a short than with a long spark gap. Fig. 88 with a long spark shows only two or three per alternation, while Fig. 89 with a shorter gap shows about twenty-five.

In order to show that each group of sparks actually represents an alternation, two parallel spark gaps were arranged, the electrodes being a plate and a point or a point and a plate. The gaps were so placed that their images on a photographic plate came side by side (Fig.

90). By this means the sparks were divided into positive and negative groups as shown in Fig. 91, on account of the greater facility with which a positive discharge commences at a point. Each spark consists, of course, of several oscillations, but these are too rapid to show on a plate driven at the speed used in these experiments. In order to obtain as many sparks per second as possible, the gap must either be decreased or the voltage raised. Of course there is a limit to this procedure, as otherwise the oscillations may become too weak, or the sparks may run into one another and become an arc which is inactive. The latter difficulty may be to some extent overcome by



FIG. 89.
Higher Rates of Sparking.

using electrodes of the so-called non-arcing metals aluminium or zinc, or by Thomson's method of using a magnetic or air blast, which breaks the arc and produces the required oscillatory discharge at the moment of rupture. On the other hand, Majorana used a stream of air or carbonic acid which played upon the spark gap, "in order to maintain the regularity of the discharge," as he puts it in his paper on the research.

There still remain two other factors which influence the number of discharges which it is possible to obtain during an alternation, namely, the inductance and capacity of the secondary system. The less the inductance and capacity of the conductors connected to any given oscillator, the

greater is the number of discharges obtainable per second, and similarly, if the capacity and inductance of an oscillator be reduced, the rate of sparking will be increased.

Since, however, Thomson's (Kelvin's) fundamental law of wave-telegraphy gives the frequency of the waves in terms of the capacity and inductance, it is as a rule best to consider the dimensions of the oscillator as given, and to

choose a transformer with as small a secondary capacity and inductance as possible. The law referred to is given in the formula

$$n = \frac{1}{2\pi\sqrt{LC}},$$

where C is the capacity,

L the inductance, and n the number of oscillations per second (the frequency).*

The wavelength λ is determinable from this by the formula $\lambda = \frac{3 \times 10^8}{n}$

metres. The influence of the dimensions of the secondary winding is well shown in the following examples. The greatest rate of sparking obtainable with the transformer used for producing the sparks shown in Figs. 88-91 was about 60 per alternation; its secondary consisted of a very large number of windings, and had therefore great capacity and inductance. With an alternating current

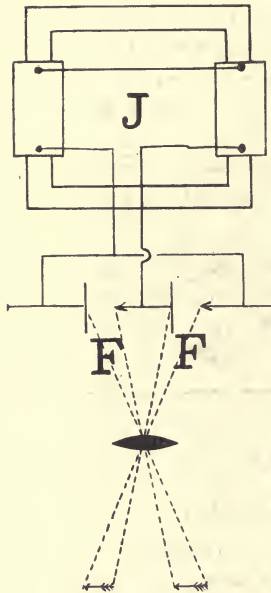

FIG. 90.

Method of Photographing Positive and Negative Sparks for Fig. 91.

transformer designed to give about 3,000 volts, and having a much smaller secondary winding, fully 200 discharges per alternation were obtainable. Supposing, therefore, that each discharge lasted say the $\frac{1}{100000}$ of a second, and con-

* W. Thomson, *Phil. Mag.*, (4) v., p. 393, 1853.

tained ten oscillations, we find that in $\frac{1}{100}$ second, namely, the duration of an alternation, the oscillations occupy $\frac{1}{500}$ second, so that the time covered by active oscillations would be to blank time in the ratio of 1:4, if the dis-



FIG. 91.

Positive and Negative Alternate Spark Groups.

charges were uniformly distributed throughout an alternation; this, however, is not exactly the case, as we have seen above.

Mercury Vapour Spark Gap.—We shall next notice

shortly the corresponding observations when a mercury vapour lamp is employed as spark gap.

If instead of the ordinary spark gap in air we employ a mercury vapour lamp at the proper pressure, there is a marked increase in the potential without any corresponding increase in the damping; it is therefore possible to excite more powerful oscillations. In addition to these, there is the advantage that on account of the very rapid variations of the resistance of the mercury vapour, there is less tendency to the formation of an arc. Hence the discharges may be made to follow one another with greater rapidity than in air. The interrupter action of a mercury lamp supplied by a high tension alternating current was first observed by Hewitt.* Investigations of this subject have also been made by Simon and Reich,† and W. Pierce.‡

The last of these photographed the discharge by means of a swinging lens on a rotating film. The best vapour pressure for a potential of 15,000 volts was found to be 0.02 mm. By using a small Leyden jar in parallel with a similar vacuum tube, Pierce obtained 200 discharges,§ each consisting of several oscillations, during an

* Cooper Hewitt, *Elec. Review*, New York, xlii., No. 8, of 21st February 1903.

† H. Th. Simon and M. Reich, *Phys. Zeitschr.*, iv., pp. 364-372, 1903; and H. Th. Simon, lecture to the Scientific Congress at Cassel on 22nd September 1903, for which see *Phys. Zeitschr.*, iv., pp. 737-741, 1903.

‡ W. Pierce, *Phys. Zeitschr.*, v., pp. 426-437, 1904.

§ In order to complete our account of this part of the subject we must take note of some recent patents in which a high tension current is used with a vacuum spark gap for the production of the oscillatory discharges used in wireless telegraphy and telephony. The Gesellschaft für drahtlose Telegraphie, of Berlin, has patented a device for producing very slightly damped oscillations, in which a condenser of large capacity is connected in parallel with the secondary of the mercury lamp transformer. The lamp itself forms the spark gap of an oscillating circuit with capacity and inductance which is connected

alternation lasting $\frac{1}{120}$ of a second, so that the pause between successive sparks was only $\frac{1}{100000}$ of a second. Each discharge was regular and sharply defined, which showed that even at this discharge rate there was no lowering of the potential by the formation of conducting vapour.

directly or inductively to the aerial (German patent, No. 160,990, of 14th April 1905). In order to increase the amplitude of the discharges Eisenstein concentrates the entire energy of each alternation into a relatively short time by using proper means for connecting the vacuum tube only during these moments to the alternator. (German patents, E. 11,332, Class 21a 4, of 5th December 1905, complete patent, 182,656, and E. Class 21a 4, of 3rd February 1906, complete No. 182,657; also French patent, No. 368,988, of 17th August 1906.)

CHAPTER XI.

MULTIPHASE SPARK DISCHARGES.

Imperfections of Spark Method.—It is therefore clear that a large number of discharges per second, each of which gives rise to an oscillatory damped current, may be obtained from an alternating current of ordinary frequency. Although it is possible by this method to obtain a sufficient discharge rate for the transmission of speech, as Majorana's experiments proved, it has still the disadvantage that in the neighbourhood of the zero of potential in each alternation there is a somewhat long pause, and that in general the discharges do not follow one another with anything like uniformity. These pauses, occurring at every reversal, disturb the transmission of speech very considerably, as the author observed in a research undertaken, independently of Majorana, in the winter 1904-5. A microphone was used to influence the supply current to the primary of an alternating current transformer.* The transmitted speech received on microphonic contact and telephone was rough and broken like that of a stammerer.

The gaps in the series of discharges, which occur when an ordinary sinusoidal alternating current is used, may be, to a considerable extent, filled up either by Blondel's

* In these experiments the microphone was connected in parallel with a coil as used by Nussbaumer (*Phys. Zeitschr.*, v., p. 796, 1904). An inductive coupling may be used in place of a direct one (Mosler, German patent, No. 173,690). Direct action on the dynamo is described in Mosler's application, M. 26,653, Class 21a 4, of 24th December 1904.

method* of using an alternating current of nearly rectangular curve, or by Eisenstein's† method of employing a

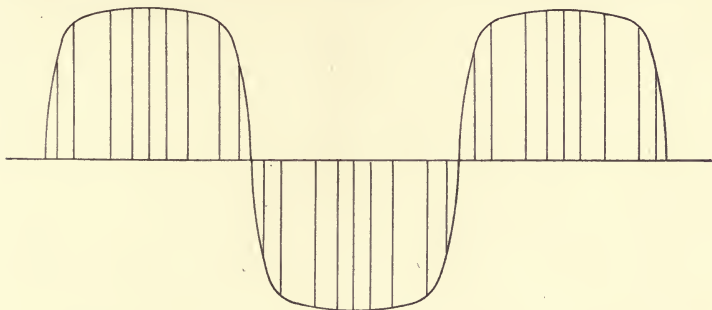

FIG. 92.

Blondel's Method of Increasing Spark Rate and obtaining more Uniform Succession of Sparks.

multiphase current. As is shown clearly in Fig. 93, it is possible by a proper arrangement of the spark gaps to make the discharges in one or other of the phases to follow

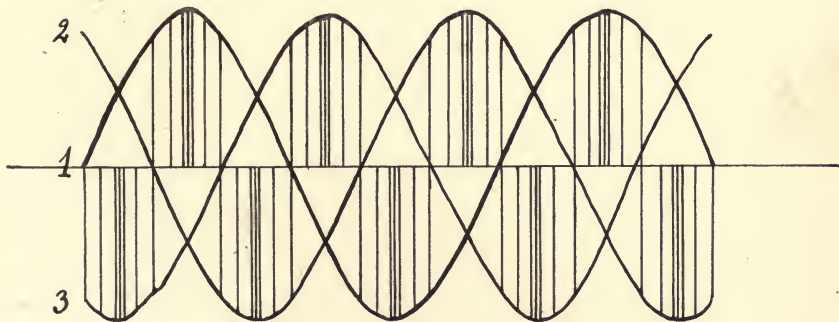

FIG. 93.

Three-Phase Current for obtaining Continuous Succession of Spark Discharges.

one another practically continuously, and thus obtain a

* See German patent, No. 159,330, of 17th August 1902, and British patent, No. 15,527, of 11th July 1902.

† See German patents, No. 175,438, of 9th July 1905, and No. 176,011, of 1st February 1906.

continuously active transmitter. The simplest connections for this purpose are shown in Fig. 94, in which it will be seen that the transmitter consists of three similar parts. Each spark gap, F, is connected to a transformer, J, and the primaries of these are in a star connection. In this

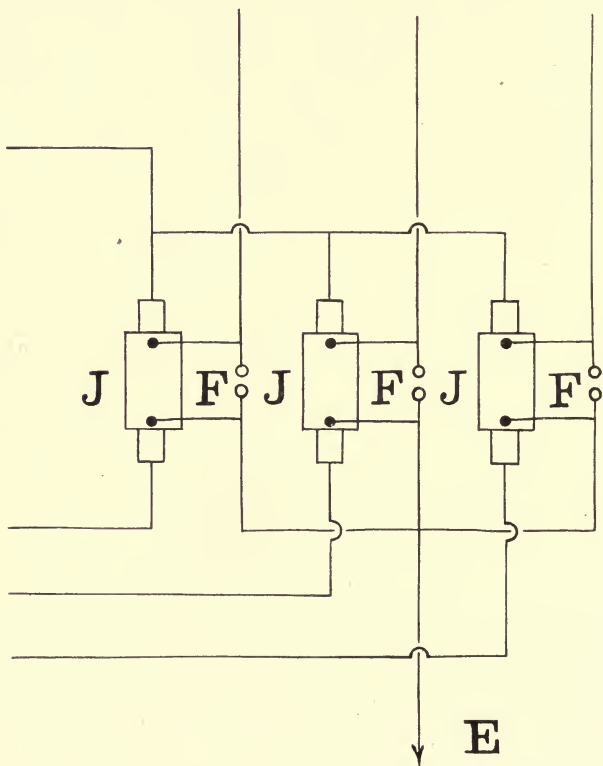

FIG. 94.

Triple Inductorium for Three-Phase Current, with Spark Gaps in Aerials.

arrangement each phase actuates practically a complete transmitter. An arrangement with only one aerial wire is shown in Fig. 95. In this case the three oscillating circuits contain a common inductance which also forms part of the aerial, an arrangement also recognisable in

Eisenstein's apparatus shown in Fig. 96. A mesh connection may, of course, be used instead of the star. Fig.

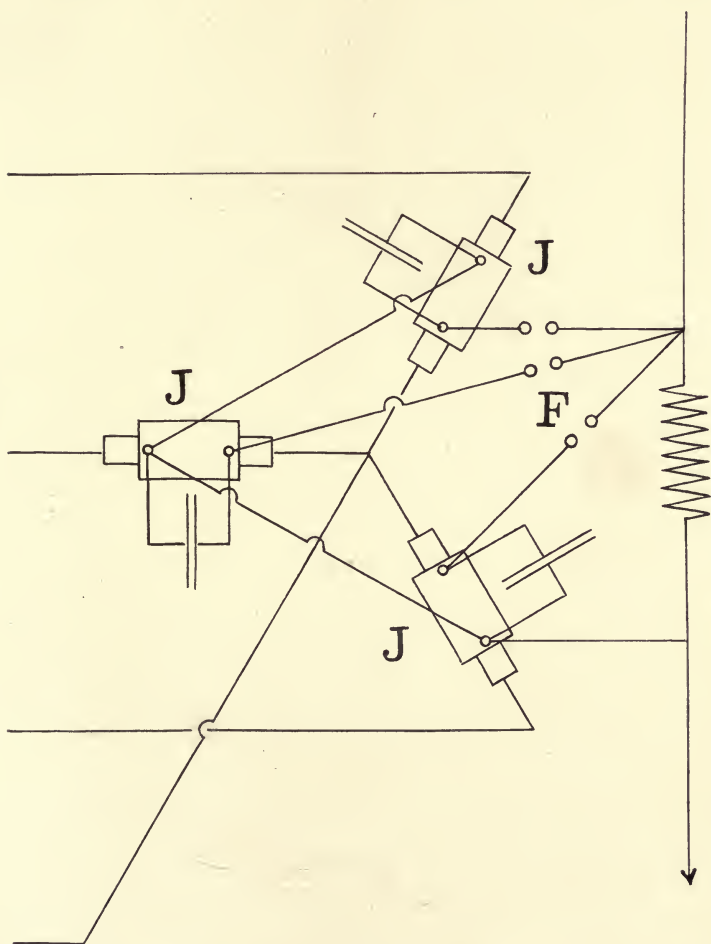

FIG. 95.
Three-Phase Transmitter with Continuous Single Aerial.

97 shows a transmitter of this type. Here the terminals of the supply circuits are connected to the primaries of the

main transformers in pairs, while all their secondaries are in series, and a third circuit, containing condensers and transformers with a three-cornered spark gap, forms the

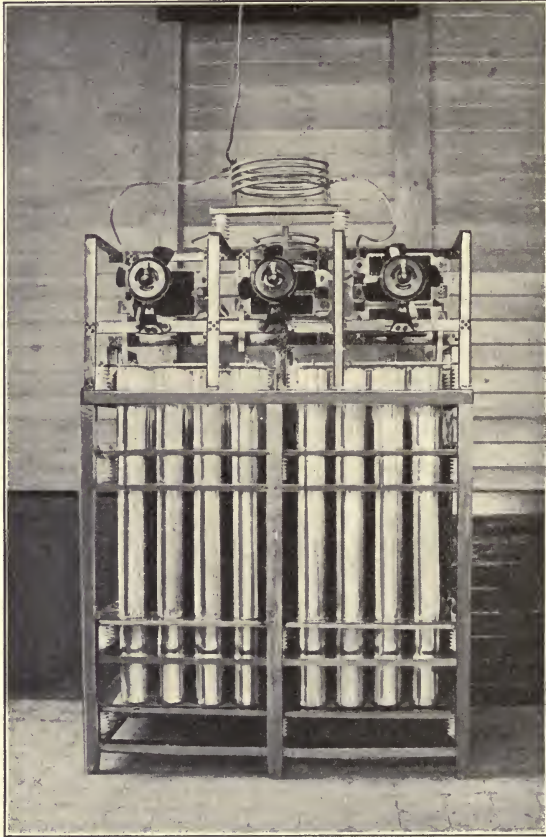

FIG. 96.

Three-Phase Transmitter.

oscillator, and is coupled to the aerial wire by the secondaries of these subsidiary transformers. The action of all the spark gaps must be alike in order that the discharges may

correspond exactly to the phases of the main current. Thus waves of the same length will be radiated from the aerial whichever of the spark gaps may at the moment be

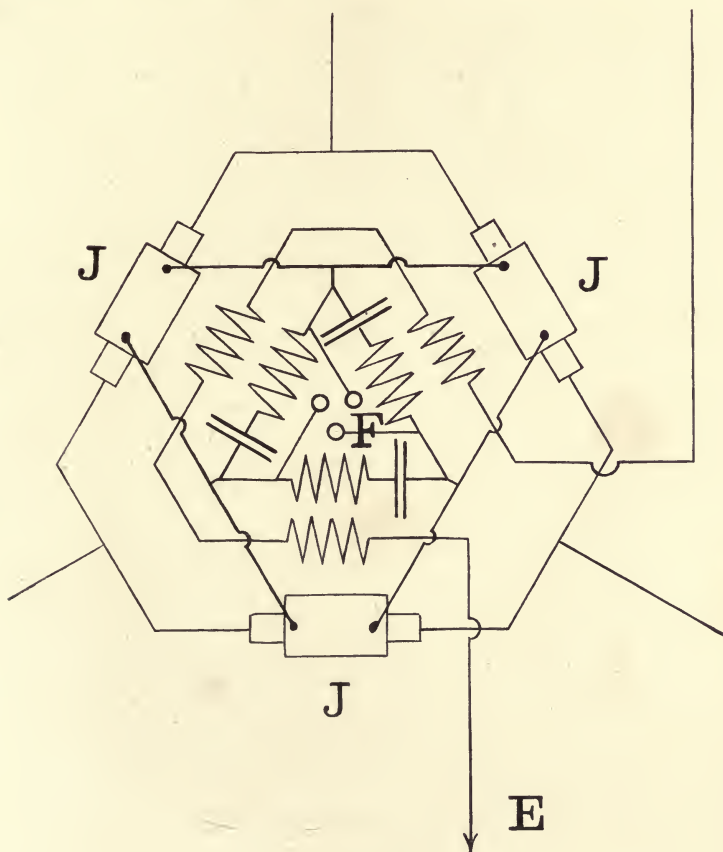

FIG. 97.

Three-Phase Transmitter, Mesh Connection.

acting. In this manner a continuously excited transmitter has been realised in practice.

Instead of a three-cornered spark gap, three separate

gaps in star connection may be used along with capacities in mesh connection.

Although in the above-described method of Eisenstein's there are no long pauses between discharges, there remain nevertheless the minor irregularities which become more and more noticeable with every increase of the voltage. This difficulty is clearly only surmountable by the use of a high tension continuous current.

A thorough investigation of this method has been made by Simon and Reich, who employed as exciting circuit of the transmitter a Braun's oscillator.*

They used as source of current a high tension dynamo,†

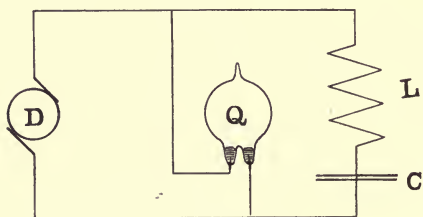

FIG. 98.
Mercury Vapour Lamp as Spark Gap.

or a battery of 5,000 volts. The secondary coil of a 40 cm. spark induction coil was used as inductance in the leads to the Leyden jar.

A continuous and steady excitation was obtained with a mer-

cury lamp as spark gap.‡ The rate of sparking increased as the voltage was augmented, as in the case of alternating current, and remained constant as long as the voltage was not varied. If an ordinary air gap was used energetic oscillations occurred at the commencement, but were immediately succeeded by an inactive arc. It is only possible to obtain a continuously active discharge when the pauses between the sparks are increased by the interposition of a considerable inductance.

* H. Th. Simon and M. Reich, *Phys. Zeitschr.*, iv., p. 364, 1903, and H. Th. Simon, lecture at the 75th Scientific Congress at Cassel on 22nd September 1903, *Phys. Zeitschr.*, iv., p. 737, 1903.

† This machine (20 PS.) was supplied by Messrs Schuckert & Co., of Nürnberg. It was model Z. H. 20, 5,000 volts, 3 amperes.

‡ See also German patent, No. 153,792, of 18th January 1903.

Simon's Theory.—The fact that the spark becomes inactive must thus be attributed to the pauses between the sparks being not sufficiently long to permit of the spark gap losing its conductivity by cooling. In the papers quoted Simon gives a quantitative discussion, which gives a most satisfactory confirmation of his experimental results and establishes many important points in the theory of the production of undamped oscillations. We shall therefore

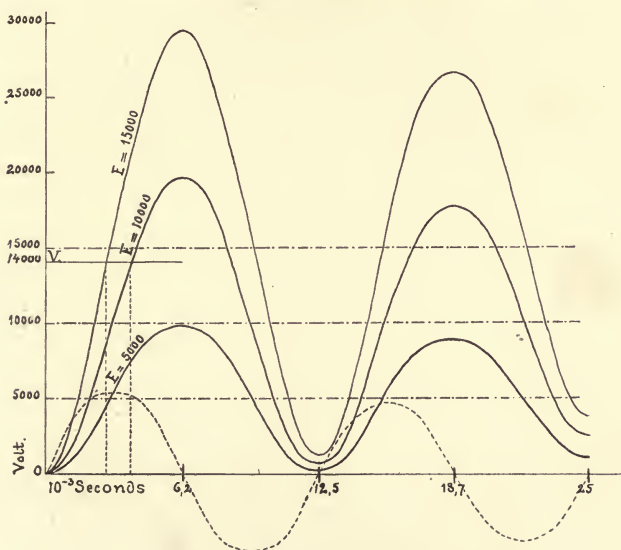

FIG. 99.
Charging Curves of an Oscillating Circuit.

give a short abstract of his investigation before proceeding further.

If a capacity C be suddenly connected at the moment $t=0$ to a source of constant potential E , its potential e at any time t thereafter is determinable by means of the equation—

$$\frac{d^2e}{dt^2} + \frac{R_0}{L_0} \frac{de}{dt} + \frac{e}{L_0 C} = \frac{E}{L_0},$$

where R_0 is the resistance and L_0 the inductance of the

circuit. The integral of this equation taken between the proper limits is—

$$e = E - \frac{2E \sqrt{L_0 C}}{\sqrt{4L_0 C - R_0^2 C^2}} \cdot \epsilon^{-R_0 t/2L_0} \times \\ \sin \left\{ \frac{\sqrt{4L_0 C - R_0^2 C^2}}{2L_0 C} t + \arctan \frac{\sqrt{4L_0 C - R_0^2 C^2}}{R_0 C} \right\}.$$

If $R_0^2 C^2$ is negligible in comparison with $4L_0 C$, and if, also, the lag in phase is nearly $\pi/2$, we get approximately—

$$e = E \left(1 - \epsilon^{-R_0 t/2L_0} \cdot \cos \frac{t}{\sqrt{L_0 C}} \right).$$

Taking into account the constants R_0 , L_0 , and C of his apparatus, Simon calculated the charging curves for various steady voltages* given in Fig. 99.

The time of discharge of the condenser, reckoned till a new discharge commences, is determined by the point of intersection of a line drawn parallel to the axis of time at a height V , with the e curve. In Simon's experiments this time was of the order of a thousandth of a second.

We may discuss in a similar way the discharge which takes place across the spark gap at every spark. We have—

$$e = \frac{2E \sqrt{LC}}{\sqrt{4LC - R^2 C^2}} \epsilon^{-Rt/2L} \cdot \cos \frac{\sqrt{4LC - R^2 C^2}}{2LC} t,$$

where R is the resistance and L the inductance of the oscillating circuit.

* The corresponding current is given by—

$$i = \frac{E}{\sqrt{L_0/C}} \epsilon^{-R_0 t/L_0} \cdot \sin \frac{t}{\sqrt{L_0 C}},$$

and is shown by a broken line in Fig. 99.

Also neglecting the damping factor $\epsilon^{-R_0 t/L_0}$ we get $e = 0$ for $t = 0$, or $2\pi \sqrt{L_0 C}$, $4\pi \sqrt{L_0 C}$, &c., and otherwise is always positive. $i = 0$, for $t = 0$, or $\pi \sqrt{L_0 C}$ or $2\pi \sqrt{L_0 C}$, &c., and is sometimes positive and sometimes negative in the intervals. The limiting value of e is $2E$; and of i is $E/\sqrt{L_0/C}$.

Under the same restriction as before, namely that R^2C^2 is negligible* in comparison with $4LC$, we obtain—

$$e = E \cdot e^{-Rt/2L} \cdot \cos \frac{t}{\sqrt{LC}},$$

i.e., a damped oscillation with the period $T = \frac{1}{n} = 2\pi \sqrt{CL}$, where n is the frequency. The damping is determined by the factor $e^{-Rt/2L}$ and the logarithmic decrement—

$$\delta = \frac{RT}{2L} = \frac{R}{2Ln}.$$

The period of the oscillations which take place at each discharge is naturally much less than that of the charging current since R and L are very much less than R_0 and L_0 . In Simon's experiments they run from about a hundred-thousandth of a second to a millionth.

The damping is somewhat considerable, particularly, as M. Wien has shown,† if Braun's form of circuit be used.

If one takes ten complete oscillations as the limit in which the potential will be so far run down that the spark is no longer maintained, one finds that the duration of the discharge in Simon's experiments is only from a ten-thousandth to a hundred-thousandth of a second, and is therefore much less than the time of charging.

From the formula given above for the variation of the condenser voltage during charging, we obtain mathematically several results of importance which we have already established experimentally. Thus we see that for any given condenser the pauses between successive discharges are smaller the greater the voltage E of the source of electricity, and the less the discharge voltage V , or the length of the spark gap. For a given supply voltage E they are shorter in proportion as V and C are less; and finally, for a given

* If this condition is not fulfilled, as in the case of a long spark gap, the discharge becomes continuous, or rather aperiodic.

† M. Wien, *Ann. d. Phys.*, viii., p. 686, 1902.

discharge voltage V , they decrease in proportion to the capacity C , and inversely as the supply voltage E .

With an alternating current supply we obtain, as we have already shown, a periodic series of unequal pauses which remain the same as long as the spark gap and capacity are kept constant.

Finally, it should be noticed that it is not always necessary that the stationary voltage of the supply current should be as great as that required for the spark, since in consequence of the oscillatory character of the charging, it is obvious that the potential at the condenser reaches a maximum during the first swing which is nearly twice as great as that of the supply (see Fig. 99, and footnote, p. 126).

We see, therefore, that with given capacity and spark length the number of discharges per second may be increased by increasing the potential of the supply up to a certain limit, which is defined by the condition that the heat liberated in each spark must be so small that the air has time to cool before the next commences. Otherwise an inactive steady arc is produced, or at best one in which the current varies over a small range only, as in Duddell's phenomenon. Without doubt this type of wave producer, which is capable of sending out a very large number of jigs* per second, would have proved very useful in wave-telephony if the still more advantageous properties of the unstable arc had not been discovered.†

* "Jig" denotes a damped train of electrical oscillations of the order of frequency used in wireless telegraphy and telephony (*circa* one million per second).

† R. A. Fessenden has recently published a description of his experiments carried out during the years 1900-4. Among other arrangements he used a rotating spark gap supplied with constant current at 5,000 volts; with 500 revolutions per second 20,000 sparks were obtained per second. Speech was transmitted, but the noise due to the sparks was disturbing (*Zeitschr. für Schwachstromtechnik*, p. 72, &c., 1907; see also Appendix).

Electrical Quantities Controlled by Sound.—The electrical discharge system may be influenced by the sound waves either as regards the intensity or frequency of the electrical oscillations in the transmitter or aerial wire, whether by action on the supply circuit, the secondary circuit, or the aerial itself. The operation may also be accomplished by a control of the rate of sparking, in which case the transmitter is not continuously excited, but acts only when influenced by the sound waves; it is therefore at rest when no sound is being communicated to it.

As an example we may take an arrangement of Blondel's, in which the supply circuit, or the oscillating circuit itself, is interrupted by means of a manometric flame.*

In the apparatus shown in Fig. 100, the voltage is chosen so that it is not sufficient, when the flame is at rest, to cause a spark. When, however, the flame commences to move up and down, the spark, which is supplied by an alternating current of the form shown in Fig. 92, jumps the gap and excites the transmitter.

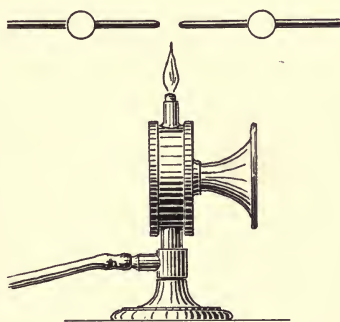

FIG. 100.

Blondel's Manometric Flame Controller.

The action is due to the variations in resistance caused by the extension of the flame between the electrodes, and is, of course, synchronous with the sound waves.

Any of the detectors mentioned in the earlier part of this section may be used as receiver in connection with a telephone in the local circuit, or the oscillatory currents in the receiving circuit may even be made to act directly on a membrane. If the latter consists of metal it may be

* See British patent, No. 15,527, of 11th July 1902, and German patent, No. 160,880, of 17th August 1902.

placed near a solenoid containing only a few turns, in which case the Foucault currents induced in it cause it to vibrate.* A condenser may be connected in series or parallel for tuning purposes.

Damped and Undamped Waves.—The foregoing methods depend on the work of Feddersen and Hertz. A comparatively slow charging is followed by a sudden and oscillatory discharge, which rapidly dies out, leaving the

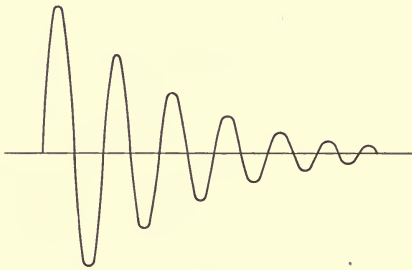

FIG. 101.
Damped Oscillations.



FIG. 102
Uniform Oscillations.

spark gap again in a non-conducting condition. The whole process may be compared to the discharge of a machine gun, *i.e.*, to a succession of impulses of great activity alternating with moments of entire inactivity. It is clear that a method of producing a continuous stream of waves like the sound of an organ pipe would be an immense advance on this system, and would open up the

possibility of a wireless telephony far more perfect than could be attained by these earlier methods.

Figs. 101 and 102 show diagrammatically the difference between damped and undamped waves. In the former the successive amplitudes of the waves decrease, in the latter they are constant.

* See Fessenden, American patent, No. 706,747, of 28th September 1901, and German patent, No. 171,535, of 13th August 1902; also Blondel, British patent, No. 15,527, of 11th July 1902. See also Appendix.

CHAPTER XII.

HIGH FREQUENCY ALTERNATORS.

High Frequency Alternating Currents.—Many experiments have been made with the object of producing a series of waves of constant amplitude, in order that sharp tuning may be obtained.*

An attempt has been made to solve the problem in a purely mechanical manner, by the construction of high frequency alternating current generators, the first machine of this type being described by Nicola Tesla in his book on "Researches on Multiphase Currents, and on the Alternating Currents of High Voltage and Frequency" (Halle, 1895).

A tabular statement of the machines of this character which have been constructed, recently given by Rautenkrantz, is reproduced below.†

As may be seen from the following table, machines have already been constructed which produce alternating currents of sufficiently great frequency for wave telegraphy or telephony; the amount of energy given out is, however, so far, exceedingly small.

* On electrical oscillations and oscillators, see C. Heinke, *Handbuch der Electrotechnik*, Bd. i., pp. 43-55, 1904.

† *Annalen der Electrotechnik*, i., pp. 617-620, 1906. See also Appendix.

HIGH FREQUENCY GENERATORS.

Designer or Constructor.	Type.	Revolutions per Minute.	Circumferential Velocity, m. per sec.	Frequency.	Output.	Literature.
NICOLA TESLA -	Alternate pole machine, with 384 poles. Field and armature windings in zigzag form. Core of iron wire.	1,600	209	5,100	100 v., 10 a.	<i>The Elec. Engineer</i> , New York, xl., p. 338, 1889.
NICOLA TESLA -	Ferranti type with rotating armature between 480 poles of field magnets. The armature is wound on a plate with zigzag cuts in it.	2,500	?	15,000	?	<i>The Elec. Engineer</i> , New York, 18th March 1891.
ELIHU THOMSON (Mechanical Laboratory of the Thomson-Houston Electric Co.)	Two fixed field coils in iron frames, surrounded by moving armature; 50 alternations per revolution.	5,000	150	4,165	1,000 v., 1 a.	American patent, No. 363,185 of 17th May 1887.
C. P. STEINMETZ (The General Electric Co.)	Moving single-phase armature -	3,750	310	10,000	100 v., 20 a.	
LODGE - (C. A. Parsons & Co.)	Moving field with radial poles. The armature coils are wound on the inward turned teeth of a split ring.	6,000	250	3,000	112 v., 3.2 a.	

HIGH FREQUENCY GENERATORS—Continued.

Designer or Constructor.	Type.	Revolutions per Minute.	Circumferential Velocity, m. per sec.	Frequency.	Output.	Literature.
Sir D. SALOMONS (Pyke & Harris.)	Field and armature rotate in opposite directions. 174 pairs of poles each side.	1,500	79	8,700	200 v., 1 a.	<i>Journal Inst. Elec. Engineers</i> , London, xxi., p. 709, 1892.
EWING - (C. A. Parsons & Co.)	Plate-shaped field magnet driven by steam turbine.	12,000	600	14,000	100 v., 5 a.	<i>The Electrician</i> , xxx., p. 65, 1892.
CENTRAL TECHNICAL COLLEGE, London.	Inductor type. 2 machines, one with magnet with 30 teeth, other with 204 teeth.	30,000 33,400	310 366	15,000 120,000	22 v., 0.25 a. 2 v., 0.1 a.	
K. E. F. SCHMIDT (Elektr. A. - G. vorm. Schuckert & Co., Nurnberg, 1906.)	Rotating field in two parts with 120 pole pieces pointing inwards between the fixed zigzag windings of the armature.	2,600	76	5,200	With 10 a. exciting current and 3 armatures in parallel. 10 v., 20 a. in series	<i>Ann. d. Phys.</i> , xiv., p. 22, 1906.
M. WIEN - (Aachen.)	Alternating current siren. Rotating field magnets; fixed armature with two coils.	2,040	185	8,500	32 v., 5.5 a. 20 v., 0.2 a.	<i>Wied. Ann.</i> , Bd. iv., p. 425, 1901.

HIGH FREQUENCY GENERATORS—Continued.

Designer or Constructor.	Type.	Revolutions per Minute.	Circumferential Velocity, m. per sec.	Frequency.	Output.	Literature.
F. DOLEZALEK - (Siemens u. Halske.)	Inductor type. Fixed horse-shoe field magnet, with continuous current excitation. Rotating toothed inductor. Armature coils on fixed pole pieces.	?	?	10,000	15 watts.	Siemens and Halske, notes of 28th Jan. 1904, and <i>E.T.Z.</i> , xxvi., p. 390, 1905.
M. LEBLANC - (The Westing- house Co.)	Inductor type. Magnet disc with 200 poles.	3,000	327	10,000	2,000 watts.	<i>Amer. Inst. of Elec. Engineers</i> , 1904, pp. 405 and 416.
THURY - (Geneva.)	Inductor type - - -	3,000	?	10,000	200 v., 8 a.	<i>Eclair. Electr.</i> , 1904, p. 65.
E. RUHMER -	Inductor type. Magnet disc with telegraphic consecutive poles very closely placed.	6,000	300	300,000	< 0.001 watt.	<i>Mechaniker</i> , xii., p. 195, 1904, and German patent, No. 169,628.
W. DUDELL -	Inductor type. Magnet disc 6 cm. diam. laminated iron; 30 teeth; rotates in concentric magnet ring with two poles on which are also armature coils (air space 0.1 mm.).	60,000	188	120,000	2 v., 0.1 a.	<i>Phil. Mag.</i> , ix., p. 299, 1905.

H.P. of Spark Discharge.—M. Wien has, for instance, estimated the output during one discharge of a closely coupled Braun's oscillator at 1955 H.P. A very great advance in the construction of high frequency alternators will have to be made before there is any possibility of transmitting energy at so great a rate as this by their means, though the fact that the receiving circuit may be dimensioned so that it may revibrate to the received waves renders transmission possible with very much smaller currents if they are sustained instead of only momentary.*

There is no doubt that in the course of time these difficulties will be got over, and it seems to the author that these or similar methods of producing a high frequency current mechanically and without the use of a condenser have a most promising future in wireless telegraphy and even more so in telephony.†

High Frequency Alternators.—The current produced by the high frequency alternator is applied by one of the known methods to the excitation of the aerial, a close coupling being generally used for this purpose. The conditions for resonance may be fulfilled by a proper choice of capacity and inductance, an extra capacity being in certain cases introduced into the alternator circuit.‡

For revibration (resonance) we must have :—

$$\tan \phi = \frac{2\pi nL - \frac{1}{2\pi nC}}{R} = 0; \text{ i.e., } 2\pi nL - \frac{1}{2\pi nC} = 0,$$

* M. Wien, *Ann. d. Phys.*, viii., 686, 1902.

† See *Zeitschr. für Schwachstromtechn.*, i., p. 114, 1907, for description of Fessenden's Condenser-Dynamo; also see Rüdenberg, German patent, No. 179,954, of 22nd October 1905; also patent specification, R. 24,609, 21a, of 3rd June 1907 (published 11th July 1907), and "A Method of Producing Alternate Currents of Any Frequency," *Phys. Zeitschr.*, 8, p. 668, 1907.

‡ See also British patent, No. 17,708, of 1902, and Erich Vossnack, German patent, No. 184,385, of 29th November 1905.

or

$$n = \frac{1}{2\pi \sqrt{LC}},$$

i.e., the impressed frequency = the natural frequency of the circuit.

The wireless telephonic transmitters which we are now considering differ from those of the spark-telephony type in the absence of a spark gap in the oscillating circuit.

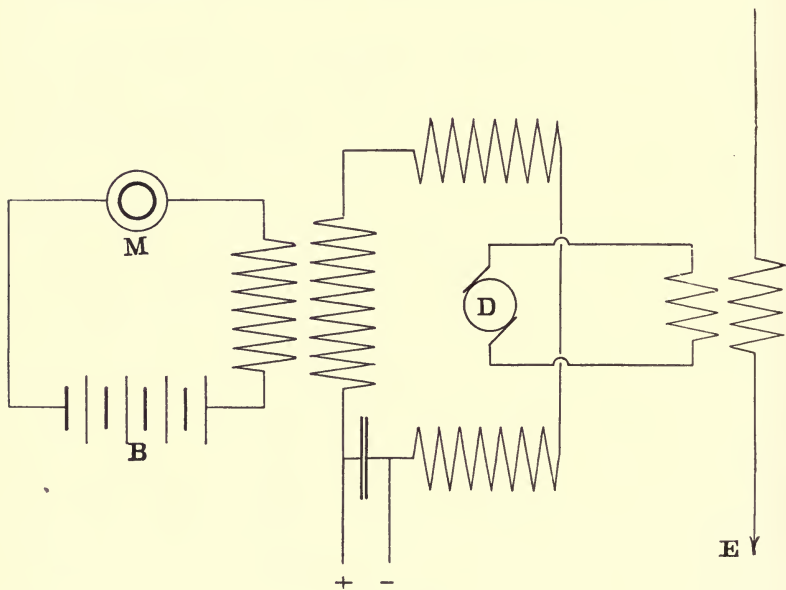

FIG. 103.

Ruhmer's High Frequency Alternator Controlled by Induction between Microphone and Field-Magnet Circuits.

The conversion of the sound waves may of course take place in any of the ways already described, and may depend on the variation of either the intensity or frequency of the oscillations. In both groups of methods the transmission of speech is by means of varying electrical waves, in the first case with constant, and in the second with vary-

ing frequency, which act with varying intensity on the detector in the receiving circuit and thus reproduce the corresponding sounds in the telephone attached to it.

When a constant wave-length is used the variations of the intensity produce similar variations in the receiver, while if transmission depends on variation of the wave-length, the receiver must be a persistent oscillator which only responds when acted upon by waves which are of its own natural frequency, and falls out of resonance when the frequency of the impressed waves varies.

The author's attempt* to influence the exciting current of a high frequency alternator by means of a microphone belongs to the first group (see Fig. 103). This group is also perfectly analogous to the method of light-telephony described in the first section of the book.

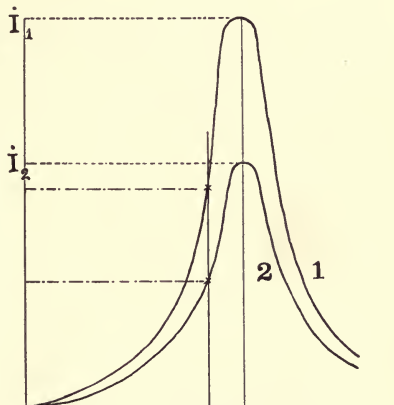

FIG. 104.

The Effects of Variation of Coupling
on Revibration.

Resonance Curves.

—Simon and Reich's †

transmitter for wireless telegraphy and telephony depends on the variation of the intensity of the radiation by alteration of the closeness of the coupling between the high frequency circuit and the aerial wire. Let curve 1 in Fig. 104 represent the resonance curve for any given coupling,

* German patent application, R. 19,015, Class 21a 4, of 14th December 1903, which, however, was refused. Fessenden has recently repeated the attempt, American patent, No. 793,649, of 30th March 1905. *Electrical World and Engineer*, xlv., p. 90, 1905; *The Electrician*, lv., p. 795, 1905; and *E.T.Z.*, xxvi., p. 950, 1905.

† German patent, No. 146,764, of 8th October 1902 (lapsed).

the abscissæ being the ratio of the natural periods of oscillation of the aerial and of the primary circuit, and the ordinates the amplitudes of the corresponding oscillations in the aerial. Curve 2 represents the conditions with a different coupling.

By varying the strength of the coupling one goes from the ordinate i_1 of the first curve to the corresponding ordinate i_2 of the second curve, while the abscissa remains constant, *i.e.*, without alteration of the ratio of the frequencies of the aerial and primary circuit. It is clearly best to work with as perfect resonance as possible, a condition indicated by the maximum ordinate.

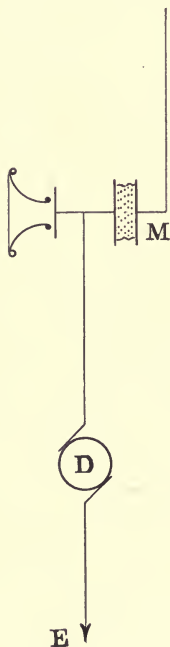

FIG. 105.
Fessenden's Micro-
phone Transmitter
in Aerial.

According to Simon and Reich the desired variation of the inductive coupling between the aerial wire and the primary system may be achieved by the use of an iron diaphragm forming part of the magnetic circuit of the transformer. The action of the sound waves on the membrane causes corresponding variations in the energy supplied inductively to the aerial. With direct coupling the strength may be altered by motion of the point of connection on the primary system.

Fessenden's Transmitters.—We shall close our remarks on this class of transmitter with a description of one of Fessenden's wireless telephones.*

Fessenden places the high frequency alternator, which must have an armature of low resistance, directly in the

* American patents, No. 706,742, of 6th June 1902, No. 706,747 and No. 753,863, of 28th September 1901. See also German patents, No. 143,386 and No. 171,535, both of 13th August 1902.

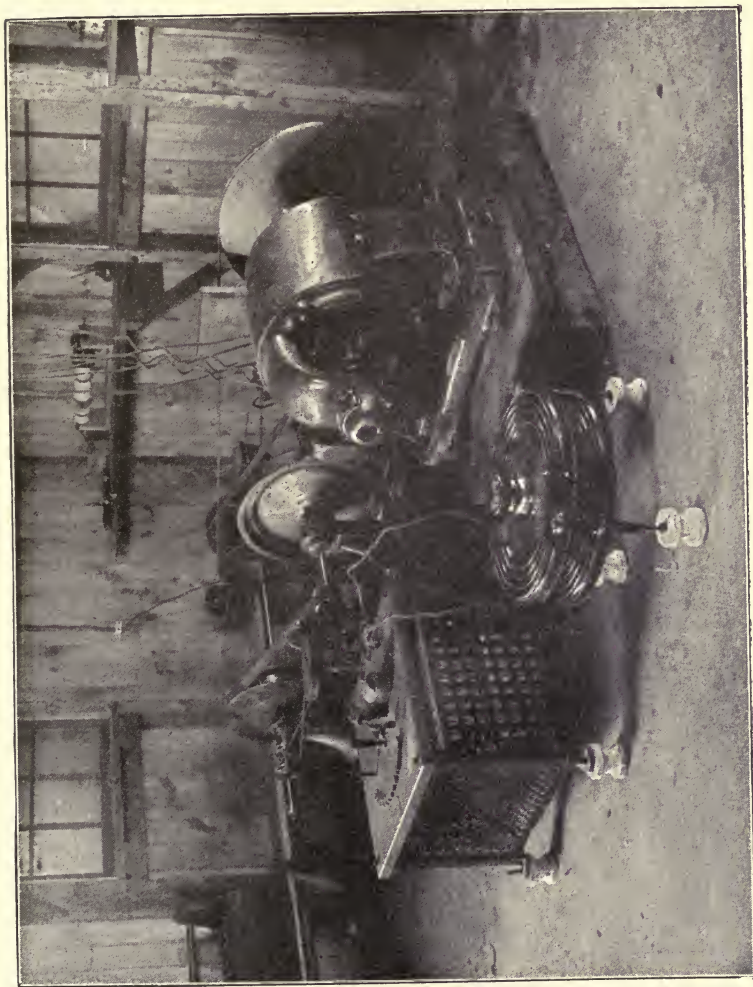

FIG. 105A.—Fessenden's H.F. Alternator giving 80,000 Cycles per Second.

earthed aerial wire, and by proper adjustments of capacity and inductance makes the natural period of the latter the same as that of the alternator current.

One of Fessenden's transmitters belongs to the first group, in which transmission is effected by variation of the intensity of the radiated waves. A microphone is inserted between the aerial and earth wires (Fig. 105). The variations of the resistance of the microphonic contact produced by the sound waves cause synchronous alterations in the current in the aerial, and therefore in the energy radiated.*

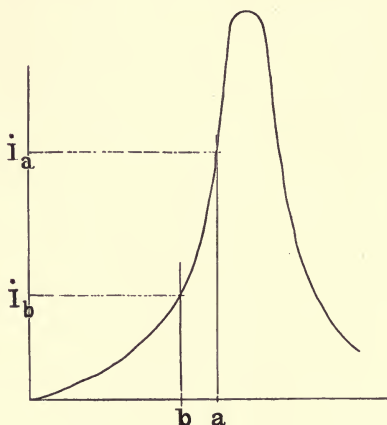

FIG. 106.

Effect of Variation of Frequency on Revibration.

In another of Fessenden's senders the control of the radiation is effected by alteration of the frequency through variation of the inductance or capacity of the aerial system. Unlike Simon

or Reich's arrangement, however, there is in this case an alteration of the ratio of the frequencies of the aerial and primary circuits, so that the conditions are represented by Fig. 106 and not by Fig. 104. In this method of

* American patents, No. 706,742, of 6th June 1902, No. 706,747 and No. 753,863, of 28th September 1901. See also German patents, No. 143,386 and No. 171,535, of 13th August 1902.

With an arrangement of this kind Fessenden carried out experiments between his Brant Rock station and a steamer, on 21st December 1906, the range being up to 16 km. Communication was also carried on with Plymouth, Mass. At the land station an alternator built according to the American patent, No. 706,737, of 29th May 1901, giving 80,000 cycles per second, was used. The resistance of

control the variation is from a given value of the abscissa a , *i.e.*, of the ratio of the natural frequencies of the primary and aerial, to another, b , and hence the amplitude of the oscillation in the aerial falls from i_a to i_b .

the armature was about 6 ohms, and it ran at 10,000 revolutions per minute. The output was only 50 watts. The receiving station had an aerial wire 21 metres high. An electrolytic cell was used as receiver. See *Scientific American*, xix., January 1907; *Zeitschr. für Electrotechn. und Maschinenb.*, xxv., p. 183, 1907; *E.T.Z.*, xxviii., p. 299, 1907; and *Zeitschr. für Schwachstromtechn.*, i., pp. 72, 93, and 114, 1907. See also Appendix.

CHAPTER XIII.

THE ARC AS HIGH FREQUENCY GENERATOR.

ALTHOUGH the methods in which an alternate current generator of high frequency is used directly are of great promise, the problem has already been solved in a different way. This solution, which we shall now discuss, depends on the employment of the musical electric arc.

The Musical Arc.—This phenomenon was first observed by Lecher, and was more thoroughly investigated later by Duddell and Peuckert.* It consists essentially in the production of a nearly sinusoidal alternating current in a circuit containing inductance and capacity in parallel with the arc (Fig. 107). In like manner oscillations are produced in an organ pipe by the action of a steady current of air connected to a vibrating system having a definite period of vibration. The arc serves to convert the continuous current into alternating current, and is, accord-

* It appears doubtful to the author whether Elihu Thomson, in 1892, observed this phenomenon or not (see pp. 179, 180; see also American patent, No. 500,630, of 18th July 1892, granted 4th July 1893; *The Electrician*, xlv., p. 477, 1901; lviii., p. 378, 1906; lviii., p. 542, 1907; *Electrical Review*, London, lix., p. 986, 1906; and *E.T.Z.*, xxviii., pp. 304, 305, 1907).

Lecher, *Wied. Ann.*, xxxiii., p. 693, 1888. See also *Phys. Zeitschr.*, iii., p. 285, 1901.

W. Duddell, British patent, No. 21,629, of 29th November 1900; *The Electrician*, xlv., p. 269 and 310, 1900; and *Proc. Inst. E.E.*, xxx., Part 148, 1901. See also *Phys. Zeitschr.*, ii., pp. 425 and 440, 1901; also *The Electrician*, li., p. 902, 1903.

Peuckert, *E.T.Z.*, xxii., p. 467, 1901.

ing to Heinke's classification, a wave producer of the second order, while the high frequency dynamo belongs to the first order.*

If the ohmic resistance of the shunt circuit is low its

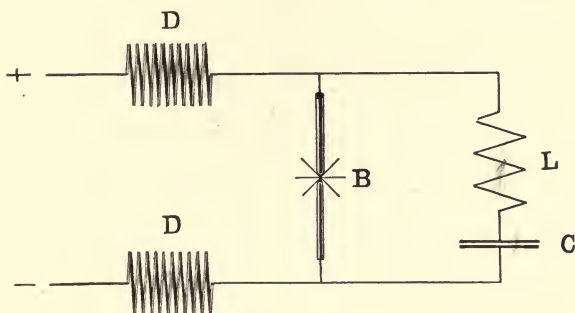

FIG. 107.

The Arc as Generator of Alternating Current.

frequency of oscillation is expressed, to a first approximation,† by the formula—

$$n = \frac{I}{2\pi \sqrt{LC}}$$

* C. Heinke, *Handbuch der Electrotechnik*, i, 2, p. 384, 1904.

† See also Tissot, *L'Assoc. Franc. pour l'Avanc. des Sciences*, 1902, and *Eclair. Electr.*, xxx., p. 354, 1902; P. Janet, *Comptes Rendus*, cxxxiv., pp. 462 and 821, 1902; J. K. A. Wertheim-Salomonsen, *Tijdschrift v. Geneeskunde*, 1902, Deel i., p. 967; "Verslag der vereeniging voor Electrotherapie en Radiologie," *Compt. Rend. du deuxième Congrès International de Radiologie et d'Electrologie Medicales à Bern*, 1902, p. 219; Stromsterkte en toonhoogte bij den fluitenden lichtboog., *Proc. Amsterdam*, v., p. 311, 1902; *Versl. Kon. Akad. Amsterdam*, p. 381, 5th November 1902; *Beiblätter*, xxvii., p. 792, 1903; Courants de haute fréquence non-amortis., *Assoc. Franc. pour l'Avancement des Sciences*, Congrès d'Angers, 4th to 11th August 1903; *Arch. d'Electr. Med.*, September 1903; *The Electrician*, li., p. 752, 1903, and *Eclair. Electr.*, xliii., p. 202, 1903; Ascoli and Manzetti, *Rendiconti dei Lincei*, xi., (2), p. 11, 1902; W. Mitkiewicz, *Journ. d. Russ. Phys. Chem. Soc.*, xxxiv., p. 229, 1902, and *Journ. de Phys.*, (4) ii., p. 223, 1903; Corbino, *Atti della Annoc. Elettrot. Italiana*, vii., p. 597, 1903;

The arc flickers in resonance with the shunt circuit, the completion of the circuit producing at once a loud and pure tone, whose pitch corresponds to the frequency of the

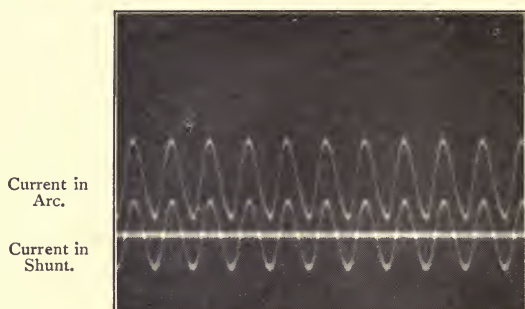

FIG. 108.

Oscillograms of Arc and Shunt Currents.

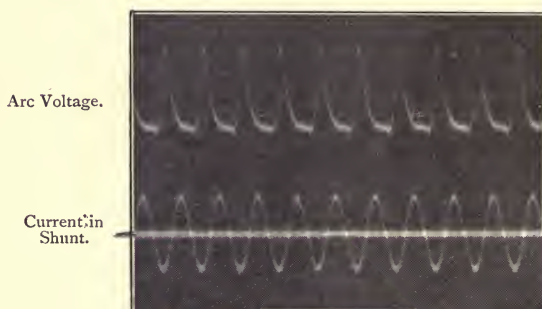

FIG. 109.

Oscillogram of Arc Voltage and Shunt Current.

electrical oscillations. By varying the capacity and inductions the pitch may be varied over a wide range.

Fabry, *Eclair. Electr.*, x., p. 375, 1903; G. Grandquist, "Ueber die Periode und die phasendifferenz zwischen Strom und Spannung im singenden Flammenbogen," *Boltzmann-Festschrift*, p. 799, 1904.

Duddell-Arc Oscillograms.—Two oscillographic records from a singing arc, which Mr W. Duddell has very kindly lent me, are reproduced in Figs. 108 and 109. Fig. 108 shows the variations of the current in the shunt circuit and in the arc, and Fig. 109 the variations of the current in the shunt circuit compared with the voltage on the arc.*

In order to retain the oscillations in the shunt circuit two choking coils are placed between its terminals and the source of current. The arc should be about 2 to 3 mm. long, between solid carbons,† the current being as small as possible. These conditions may be expressed according to Kaufmann's theory of discharge in gases by saying that the arc must be on the falling branch of its characteristic, *i.e.*, of the curve which expresses the relation between the voltage at its terminals and the current in it, or symbolically—

$$\frac{dE}{dI} \text{ must be negative.} \ddagger$$

Theory of the Vibrating Arc.—Of the numerous theories § of the unstable arc which exist, that of Blondel and Simon is the most complete. The "static" characteristic of the carbon arc, determined by H. Ayrton, is shown in Fig. 110. It is a falling curve, and though it explains the phenomena to a certain extent it does not account for all the experimental results which have been

* In these photographs the curve for the shunt circuit appears to be 180 degs. ahead of the second curve, since similar currents in the two circuits produced opposite deflections on the oscillograph.

† If a sufficiently high voltage be used, a vacuum tube may be used instead of a carbon arc.

‡ W. Kaufmann, "Göttinger Nachrichten," p. 243, 1899, and *Ann. der Physik.*, ii., p. 158, 1900; W. Duddell, *loc. cit.*; and H. Th. Simon and M. Reich, *Phys. Zeitschr.*, iii., p. 278, 1901, and iv., p. 364, 1903. Also H. Th. Simon, *Phys. Zeitschr.*, iv., p. 737, 1903, and vii., p. 435, 1906.

§ See, for instance, S. Maisel, *Phys. Zeitschr.*, iv., p. 532, 1903, v., p. 550, 1904, vi., p. 38, 1905; A. Blondel, *Comptes Rendus*, cxl., p. 1680, 1905; H. Th. Simon, *Phys. Zeitschr.*, vii., p. 433, 1906; *E.T.Z.*, xxviii., pp. 295 and 314, 1907.

obtained. Though one can see, for instance, why with a small current, or a high voltage and large resistance in series, it is much more easy to start the oscillations than with greater currents, the fact that the frequency depends both on the current and on the length of the arc remains unexplained, as also the fact, which is of great importance in wave-telephony, that there is a limit beyond which the frequency does not rise. The largest permissible supply current to the arc is between 4 and 5 amperes, it

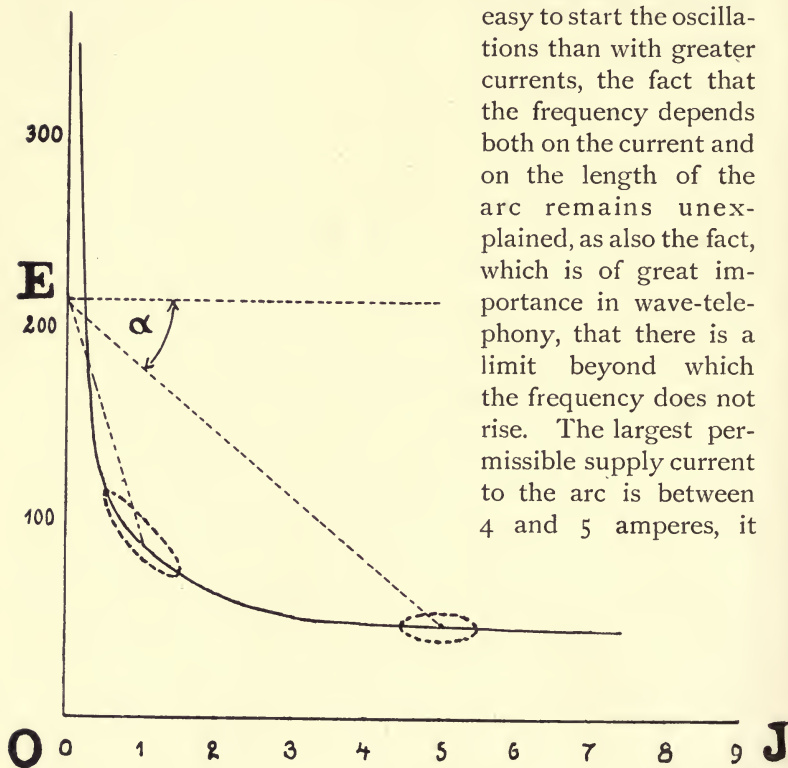

FIG. 110.

H. Ayrton's Characteristic Curve of the Arc.

being practically impossible to excite the oscillatory circuit with a carbon arc if the current be greater. The theoretical reason is the flatness of the curve, as shown in Fig. 110.*

* If in Fig. 110 a parallel to the axis of abscissæ be drawn through a point corresponding to the voltage E of the supply, then the series resistance will be represented by the tangent of the angle α formed by

The maximum frequency obtainable with the carbon arc in air appears to be about 40,000 per second.*

A theory which agrees with all observations may be based on the dynamical characteristic of the arc, which

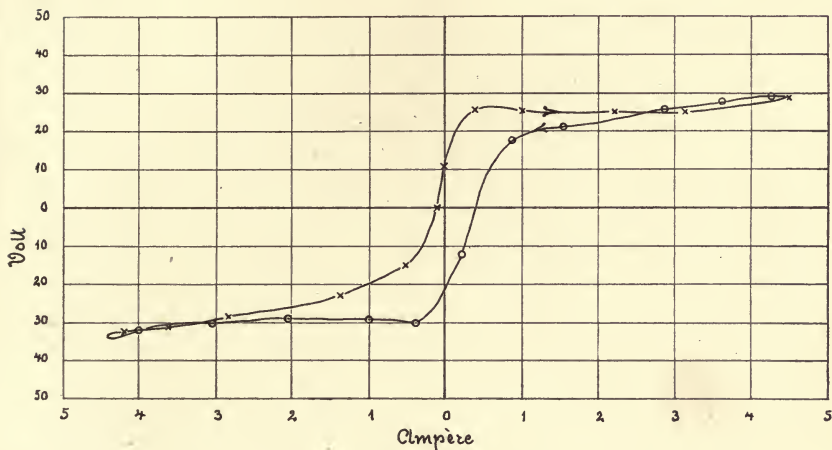

FIG. III.

Hysteresis Curve of the Arc.

shows an arc-hysteresis, analogous to the magnetic hysteresis of a circuit containing iron. This phenomenon is essentially connected with the fact, noticed by Ayrton †

a line through E to the point on the characteristic considered and by the line drawn as above. The line from E to the characteristic is sometimes called the resistance line. An increase in the series resistance corresponds to a turning of this line so as to increase α ; a rise of supply voltage to a parallel motion of the line in an upward direction.

* Duddell explains this on the supposition that for high frequencies dE/dI becomes positive (*The Electrician*, li., pp. 752, 1902, p. 126, 1903. See also *Arch. f. d. ges. Physiol.*, cvi., p. 120, 1904). The opinion of the author, who repeated these researches with exceedingly small currents and obtained frequencies as high as 300,000, is that we have here to deal with the impure Duddell phenomenon (see Chapter XVII.).

† H. Ayrton, "The Electric Arc," London, 1902.

and more exactly investigated by Simon* through the use of an oscillograph, that the characteristic curve of an alternating current arc shows lower voltages when the current is decreasing than when it is increasing (see Fig. 111). It also depends on the supply current, the length of the arc, the thermal conductivity and nature of the electrodes, and on the nature, temperature, and pressure of the surrounding gas. We thus find that, on taking oscillographic records of the current and voltage of the arc, we obtain a dynamical characteristic which shows

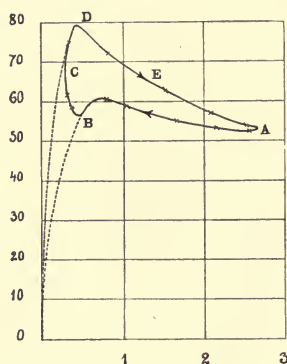

FIG. 112.

Characteristic Curve of the Oscillating Arc.

high voltages with increasing currents, and low ones with decreasing currents, forming a hysteresis loop (Fig. 112).

The complete process may be described, in the case of the Duddell phenomenon, as follows:—

The alternating current flowing out of the oscillatory circuit superposes itself on the constant current in the arc, and thus turns it into an oscillating current, which lags 180 degs. behind the current in the shunt circuit, *i.e.*, it is increasing while the shunt current is decreasing, and *vice versa* (see Fig. 113). Thus at the moment when the arc current passes its maximum the shunt current goes through its minimum; the arc becomes smaller while the shunt current increases and commences to charge the capacity. In consequence of the slow cooling of the negative crater the conductivity of the arc remains large, and hence the voltage small. This is represented by the part ABC of the

* H. Th. Simon, *Phys. Zeitschr.*, vi., p. 297, 1905; *E.T.Z.*, xxvi., pp. 818 and 839, 1905.

curve in Fig. 112. When the shunt current has reached its maximum and begins to decrease, the current in the arc again tends to increase, but on account of the lower conductivity due to cooling of the negative electrode, a greater voltage is required than before, and the part CDA of the curve represents the conditions while the current in the arc

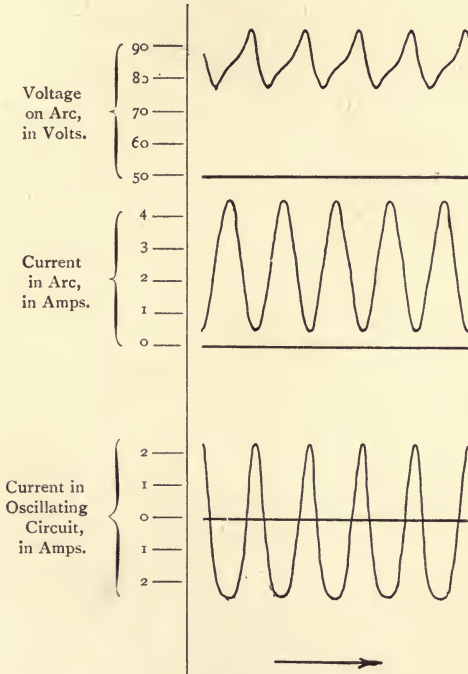

FIG. 113.

Oscillograms from the Oscillating Arc Circuits.

is increasing. The voltage increases until the cathode is again white hot (D), and after this point the voltage rapidly falls with increase of current (DEA). Whenever the capacity is charged it begins to discharge itself through the arc, thus increasing the latter until the maximum current is reached and the cycle recommences (A, Fig. 112). The fact that

the curve encloses an area indicates that energy has been absorbed by the oscillating circuit.

Simon gives in addition a graphic method which lets the conditions of the energy be more clearly seen, and shows that in general more energy goes into the oscillating circuit than comes out of it. This explanation, into which we shall not go further, also shows why the amplitudes of the voltage and current oscillations cannot rise above certain values, and hence the oscillation attains a stationary state with great rapidity.

Such points as the inactivity of the arc with large currents, the influence of the current and the length of the arc on the frequency, and finally the impossibility of exceeding a certain limiting frequency, which is higher the smaller the current, are all most clearly explained by Simon's theory. The theory itself depends on the assumption that the product of the temperature and area of the negative crater is determinate for the drop in voltage which produces a given current in the arc.

The immense importance of the singing arc for wireless purposes was early recognised. Duddell and Simon indicated that the production of this type of pure sinusoidal electric waves would make tuning easy, and must solve the problem of electric wave-telephony.* Although it was not possible to make a practical application of the method so long as a frequency of only 30,000 or 40,000 per second was obtainable, this difficulty has also been overcome.

The investigations of Nussbaumer † and Mosler ‡ must next be noticed, though they belong in reality to spark telephony in that the singing arc is supplied by a trans-

* W. Duddell, British patent, No. 21,629, of 1900, "Complete Specification," p. 4, lines 24-29; H. Th. Simon, *E.T.Z.*, xxii., p. 513, 1901; also Simon and Reich, *Phys. Zeitschr.*, iii., p. 278, 1901, iv., p. 364, 1903; and Simon, *Phys. Zeitschr.*, iv., p. 737, 1903.

† Nussbaumer, *Phys. Zeitschr.*, v., p. 796, 1904, and *E.T.Z.*, xxv., p. 1096, 1904.

‡ Mosler, *E.T.Z.*, xxv., p. 1014, 1904, xxvi., p. 490, 1905.

former, and that the amplitude and frequency of the oscillations are controlled by a microphone.

The same is true of Eisenstein's proposal to make an inactive arc active when influenced by the sound waves. For this purpose the primary coil of a microphone trans-

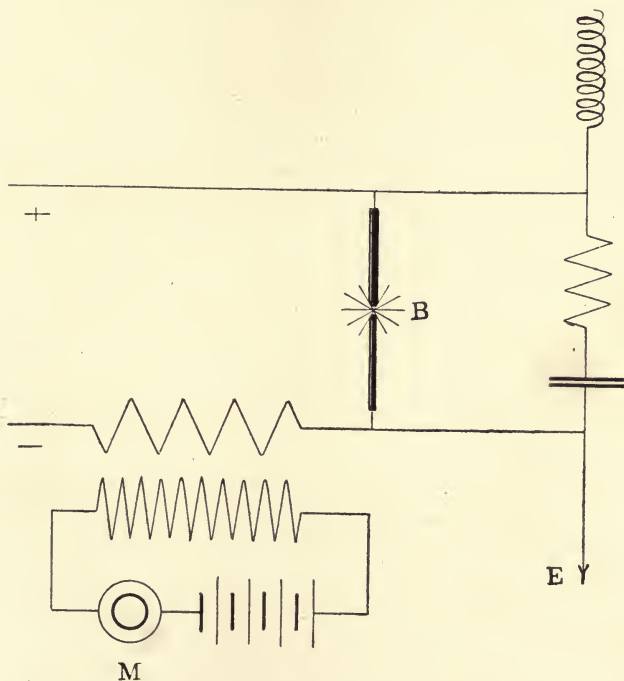

FIG. 114.

Koepsel's Method for the Transmission of Electric Waves which are Identical in Form with the Sound Waves.

mitter, with so great an inductance that the arc no longer sounded, was put in series with the oscillating circuit.*

If now one speaks into a microphone connected to a battery in series with the secondary coil, the inductance of

* S. Eisenstein, German patent, No. 166,678, of 8th July 1904 ; British patent, No. 26,696, of 1904 (7th December 1904).

the primary is reduced, and the arc sounds in sympathy with the voice. The oscillations thus produced are transformed to a high voltage and supply an aerial wire in which there is a spark gap.

The use of a spark gap in this system causes an alteration in the frequency, and the production of trains of damped waves following one another with great rapidity. Koepsel* has, however, devised another method by which

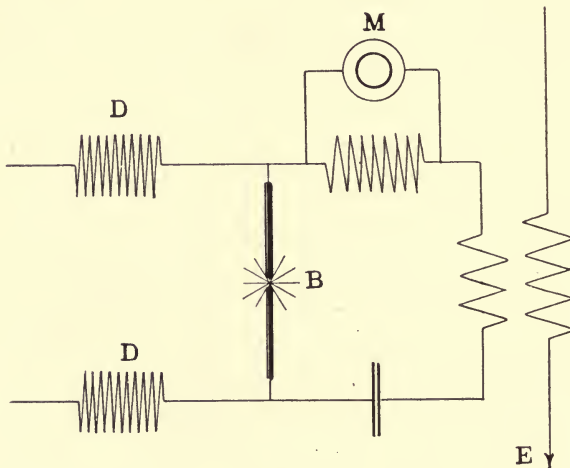

FIG. 115.
Campos' Transmitter.

the comparatively slow oscillations of the musical arc may be used directly for the excitation of the aerial wire without the necessity of the latter being excessively long.†

* Koepsel, *E.T.Z.*, xxv., p. 1107, 1904. His patent here noticed (K. 24,734, Class 21a, of 14th February 1903), which was published in the *Reichsanzeiger* of 13th May 1904, but was not completed owing to non-payment of the patent fee, was kindly lent me on 4th February 1907 by Dr A. Koepsel.

† For a frequency of 40,000 per second the length of the aerial would require to be $\lambda/4 = 1,875$ metres.

This device consists in the shortening of the aerial necessary for resonance by using a magnetic material or by constructing it in a coiled or zigzag form.*

The sound acts through a microphone, the current of which is superposed on the supply current of the arc, and thus directly or indirectly affects the aerial wire (see Fig. 114).

Unfortunately, for want of financial support, Dr Koepsel's laborious experiments came to no practical issue; as he himself expresses it, the modern commercial engineer is at best a crassly egotistical Mæcenas.

We must also notice here a transmitter designed by Campos, in which the microphone is in parallel with an inductance in the oscillating circuit, so that, on speaking into it, the variations in its resistance cause temporary corresponding alterations in the frequency of the oscillations (Fig. 115).

The Beginnings of Wave-Telephony.—It was only after the singing arc had been utilised for the purpose of producing electrical oscillatory currents that wave-telephony became practical. Quite recently three methods have been discovered by means of which the frequency of the arc vibrations may be increased sufficiently for this purpose, and these we shall consider before explaining their application to wireless telephony.

* The frequency of oscillation of the aerial may also be reduced by increase of capacity. For an arrangement of this sort see Fessenden's American patent, No. 706,737, of 29th May 1901, and German patent, No. 143,386, of 13th August 1902.



CHAPTER XIV.

THE POULSEN GENERATOR.

Poulsen.—Poulsen was the first to solve the problem of the production of relatively intense oscillations of high frequency by means of the Duddell phenomenon, by placing the arc in an atmosphere consisting of a gas of high thermal conductivity instead of in air.* Hydrogen, or a compound of hydrogen, was found to be the best. He also found that the apparatus works still better if the arc is between a cooled metallic electrode as anode and a solid carbon as cathode.†

* V. Poulsen, Danish patent, No. 5,590, of 15th December 1902, granted 2nd April 1903; American patent, No. 789,449, of 19th June 1903, granted 9th May 1905; German patent, No. 162,945, of 12th July 1903 (patent application, P. 15,041, Class 21g, published 20th April 1905); British patent, No. 15,599, of 1903, application dated 14th July 1903, completed 13th April 1904, granted 14th July 1904; French patent, No. 338,725, of 1st December 1903, granted 6th June 1904, and lecture at the Festsitzung der Electrotechnischen Vereins, 23rd October 1906 (*E. T. Z.*, xxvii., pp. 1029 and 1040, 1906), and lecture in the Queen's Hall, London, 27th November 1906 (*Engineering*, lxxxii., p. 734, 1907). See Appendix for Fessenden's patents on same subject.

A mercury arc, or, with high voltages, a vacuum tube, may be used (see Danish patent, No. 8,073, of 1904). It is interesting to note that Righi had already used a vacuum tube in 1901-2 in researches of the Duddell arc, and had found that one containing hydrogen gave the best results (see A. Righi, "Sui fenomeni acustici dei condensatori," *Memoria letta alla R. Accademia delle Scienze del l'Istituto di Bologna*, nella sessione del 25 Maggio 1902, Bologna, 1902, p. 8, line 14).

† Simon mentioned in his lecture at the Scientific Congress in Cassel that increased cooling of the arc or electrodes, and particularly of the cathode, must have an important influence on the discharge,

The electrodes used by Poulsen in his generator of undamped electrical oscillations are shown in Fig. 116. The copper anode, which luckily does not wear at all rapidly, was cooled by means of a current of water. The cathode consisted of a carbon cylinder of comparatively great diameter.

A transverse magnetic field is applied in order to keep the arc in the best position, which is at the top with its ends on the sharp edges of the electrodes.

In order to maintain the length of the arc constant, which is of great importance, the carbon electrode is slowly rotated on its axis, with a circumferential velocity of about

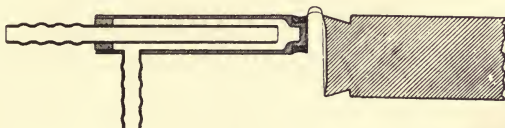

FIG. 116.
Poulsen's Arc Electrodes.

0.1 mm. per second. After the carbon has made one complete revolution it is necessary to put in a new one.

The arc is enclosed in a box with cooling arrangements,

but made no statement of results as he had then in hand a thorough investigation of the whole problem (see I. Stark, *Ann. d. Phys.*, xii., p. 673, 1903, and *Phys. Zeitschr.*, v., p. 264, 1904; also H. Ayrton, "The Electric Arc," London, 1902; Gustave Grandquist, "Ueber die Bedeutung des Wärmeleitungsvermögens der Electroden beim elektrischen Lichtbogen," *Kgl. Ges. d. Wiss. zu Upsala*, 1902, and *Phys. Zeitschr.*, iv., p. 537, 1903; B. Monasch, "Der elektrische Lichtbogen," Berlin, 1904, p. 34; I. Stark and L. Cassuto, "Der Lichtbogen zwischen gekühlten Elektroden," *Phys. Zeitschr.*, v., p. 264, 1904.

The alternating current in the oscillating circuit loses its sinusoidal form in Poulsen's arrangement in consequence of the difference of the materials from which the electrodes are made.

Simon (*E.T.Z.*, xxviii., p. 317, 1907) considers that the action of Poulsen's arrangement depends entirely on want of symmetry of the electrodes even in the case of two electrodes of the same material in hydrogen (see also p. 181).

through which the gas is passed. Poulsen has found that ordinary lighting gas is very suitable. It should also be stated that in this gas, as in others, the activity of the arc, *i.e.*, its power of producing high frequency oscillations, depends on the current and on the length of the arc.

The arc only becomes active, with a water-cooled electrode and difference of potential of 220 volts, when the current is below 6 amperes ; the limit for an electrode which

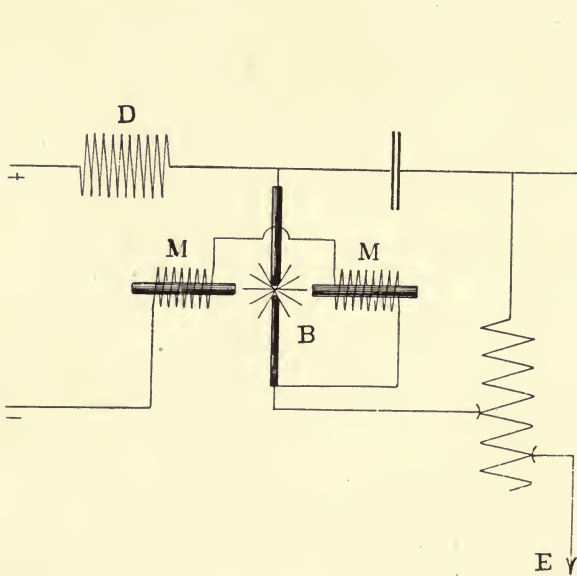

FIG. 117.
Poulsen's Arc with Magnetic Blast.

is not cooled being about 4 amperes. The frequency is supposed to be about 500,000 per second in this case. The arc must also be of a certain length, which Poulsen calls the "active length," though after the oscillations have commenced this may be somewhat reduced.* This active

* In his lecture in 1906 Poulsen showed clearly the influence of the length of the arc but only mentioned the strength of current in

length increases with the current and decreases with the frequency. If the critical current is exceeded, or the active length of arc not reached, the arc loses its property of exciting oscillations and becomes inactive.

Both of these limiting conditions may be conveniently controlled by the magnetic field used to fix the arc. Although a permanent magnet* may be used if necessary to fix the arc, Poulsen uses in his generator two large

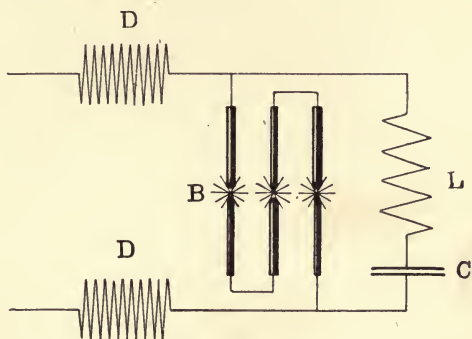

FIG. 118.

Shunt Circuit Oscillator with Arcs in Series.

electro-magnets in series with the supply current to the arc, which also serve as choking coils in the principal circuit † (see Fig. 117).

connection with the amount of energy of the oscillations. "The energy of the oscillations increases with the current in the arc, though only up to a certain point." Further information is given in the British and American patents—for instance, American patent, No. 789,449, p. 1, line 90. "Experiments with this apparatus show that as the intensity of the continuous current increases the amplitude of the alternate currents diminishes or collapses and will finally cease, but the reason is not at present known."

* Such a magnet is shown in the German patent (Fig. 11) and in the provisional British patent (Fig. 16), while in the first American and Danish patents there is no mention of a magnetic field at all.

† This arrangement occurs for the first time in the French patent of 1st December 1903 (Figs. 4-6).

This strong magnetic field has the advantage that it increases the voltage necessary to maintain any given length of arc, a 3-mm. arc requiring, for instance, 440 volts, and also that the arc remains active with considerably larger currents.

This application of a strong magnetic field to the widening of the active limits also produces, in the author's opinion, an essential change in the character of the discharge. The arc no longer sings freely, but executes forced vibrations, a fact which is only indirectly noticed by Poulsen, who remarks that the use of a strong electro-magnet in series with the supply circuit generally enables one to obtain a more powerful oscillation in the condenser circuit.* The influence of the magnetic field is clearly shown in his wireless telegraphy experiments between Lyngby and Esbjerg (about 300 km.), in which the energy, originally amounting to only 100 watts with a supply current giving 700 watts (240 volts and 3 amperes), rose to 400 watts with an energy supply of 2,800 watts (240 volts and 11.7 amperes).

Multiple Arcs.—In order to increase the radiation still further, Poulsen uses several arcs in series in an atmosphere of hydrogen.† It should be noted that for a given supply voltage the radiated energy varies inversely as the frequency, *i.e.*, directly as the wave-length.

With this we come to the second method of producing high frequency oscillations by means of the singing arc.

* See British patent, p. 6, line 51, *et seq.*, "An essentially more useful effect can be obtained by placing the conductor or the arc in a magnetic field, the lines of force of which are perpendicular or parallel to the conductor."

† The same end may be attained by increasing the pressure of the hydrogen. (See also R. A. Fessenden, American patent, No. 706,741, of 5th November 1901, and S. Eisenstein, patent application E. 10,087, Class 21a, received 1st June 1904 (refused).)

CHAPTER XV.

MULTIPLE ARCS IN AIR.

EXPERIMENT has shown that high frequency oscillations may be produced by the use of several arcs in series burning in air (Fig. 118). An arrangement like this, in which solid carbons are used, is shown in Duddell's patent,* and was given also by Campos and Mosler, although it does not appear to have been used for the production of high frequency oscillations until quite recently.†

Campos used, for instance, in one of his carefully measured experiments, ten arcs in series. The energy obtainable in this manner is, however, comparatively small,‡ though it may be somewhat increased by the use of cooled metal electrode as positive. This method has been thoroughly developed by the Gesellschaft für drahtlose Telegraphie in Berlin. Fig.

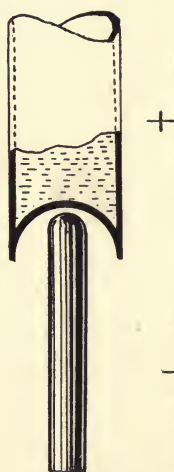

FIG. 119.
Vertical Water-Cooled Arc.

* "Complete Specification," p. 3, lines 51, 52. See "Die Schwachstromtechnik in Einzeldarstellungen," vol. ii.; D. Mazzotto, "Drahtlose Telegraphie u. Telephony," p. 278, or English edition of same.

† H. Mosler, *E.T.Z.*, xxv., p. 1014, 1904.

‡ See W. Hahnemann, *E.T.Z.*, xxvii., p. 1089, 1906, and xxviii., p. 353, 1907. The last reference is to a case in which the energy was increased from 20 to 100 watts by using hydrogen.

119 shows the construction.* The carbon electrode reaches into the concave end of the copper vessel filled with water, which forms the positive electrode. The regulation of an arc of this type may be easily achieved if the insulated carbons be attached to a piece of wood which may be turned about a vertical axis. The copper electrodes are placed above the carbons. The arcs are next

individually adjusted so that by the motion of the wooden support they may be simultaneously struck and regulated. Since the wasting of the carbon cathode is very slow when used with this form of anode, it is only necessary to turn the support very slightly from time to time in order to maintain the proper length of arc for the production of oscillatory currents.

With a supply voltage of 220 volts, six arcs may be used in series, and so on in the same proportion.

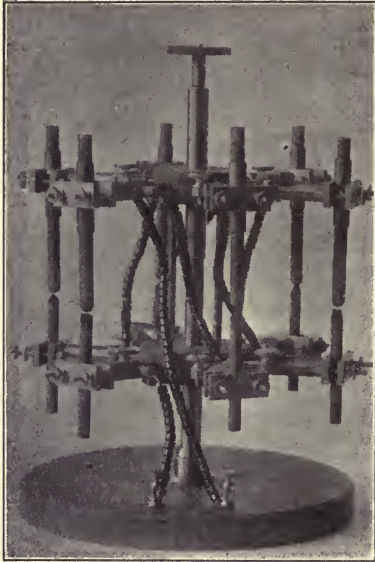

FIG. 120.
Arcs in Series.

Fig. 120 shows a set of six arcs constructed by the author for experi-

mental purposes in which the arcs may be regulated either separately or simultaneously.

As in the case of the Duddell phenomenon, there is a critical value of the current beyond which no oscillations

* The dissymmetry of the arc in the Poulsen generator holds also in this case. (See also H. Th. Simon, *E.T.Z.*, xxviii., p. 317, 1907). See patent application G. 23,718, Class 21a, of 6th October 1906.

are excited.* The limit for a supply voltage of 220 volts, and a frequency of 500,000, is about 5 amperes.

In the third method of this type metal electrodes are used with a high voltage but small current arc.† We have already noticed this system on p. 154.

The Author's Experiments on Limit of Frequency.

—The author has investigated and developed this method.

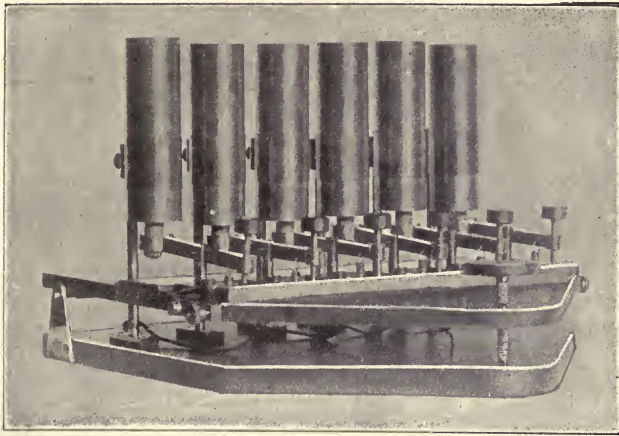

FIG. 120A.

Adjustable Battery of Arcs.

The experiments were based on the fact that the critical current of a singing arc is greater, the greater the capacity of the condenser in the jig circuit. Oscillations would, for instance, still be produced with a current of 20 amperes at 220 volts if the capacity were about 150 microfarads.

* This phenomenon is the basis of an apparatus used by the Gesellschaft für drahtlose Telegraphie of Berlin, for testing arc oscillators (Patent G. 23,994, Class 21*a*, of 3rd December 1906).

† See also B. Monasch, Patent M. 30,884, Class 21*a*, of 27th October 1906.

The author concluded from this consideration that, since high frequencies necessitate small capacities, only small currents can be used in their production. As, however, it

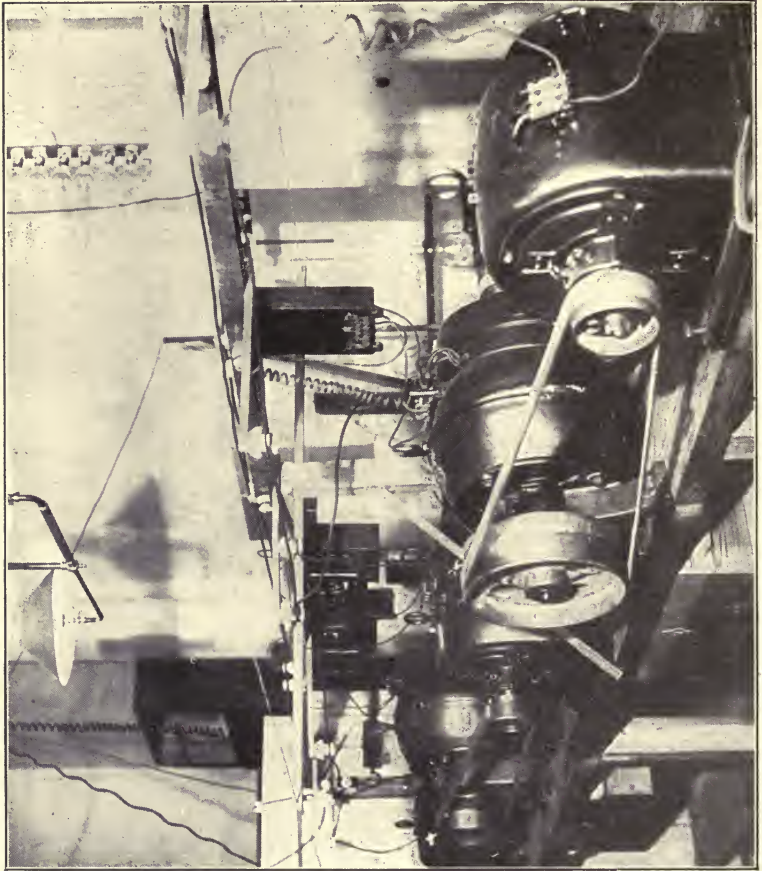

FIG. 121.—High-Tension D.C. Arc Plant

is under ordinary conditions impossible to maintain a small current arc by connection to a central station supply, and also because even if this could be satisfactorily done, the energy would be too small for practical purposes, the

author decided to employ a high tension arc. The continuous current required for this purpose was generated by several motor-driven dynamos in series; each of these was of 2 kilowatt output, and the total voltage attained was 2,500 volts. A photograph of the apparatus is shown in Fig. 121.

A coil of high inductance and a variable glow-lamp resistance of from 1,000 to 16,000 ohms were inserted in the supply circuit to the arc.

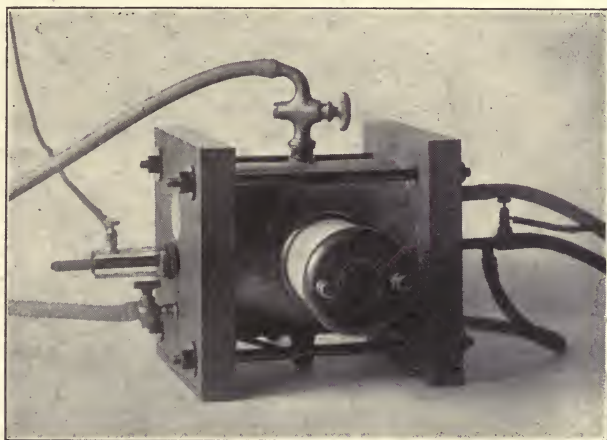

FIG. 122.

Arc enclosed in Gas Chamber.

At first solid carbons were used, but these were shortly replaced by aluminium rods or tubes. Later on a copper rod was employed as anode, and a slowly rotating sharp-cornered aluminium rod as cathode. The length of the arc was usually only a fraction of a millimetre.

The energy may as usual be increased by cooling the electrodes or applying a magnetic field. The disadvantage common to the apparatuses used by Poulsen and by the Telefunken Company, that the burning away of the elec-

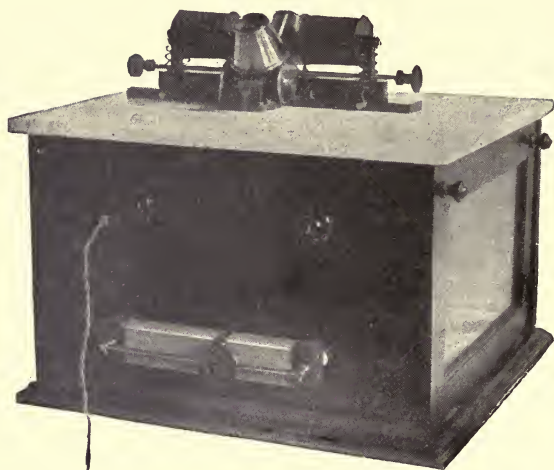

FIG. 122A.

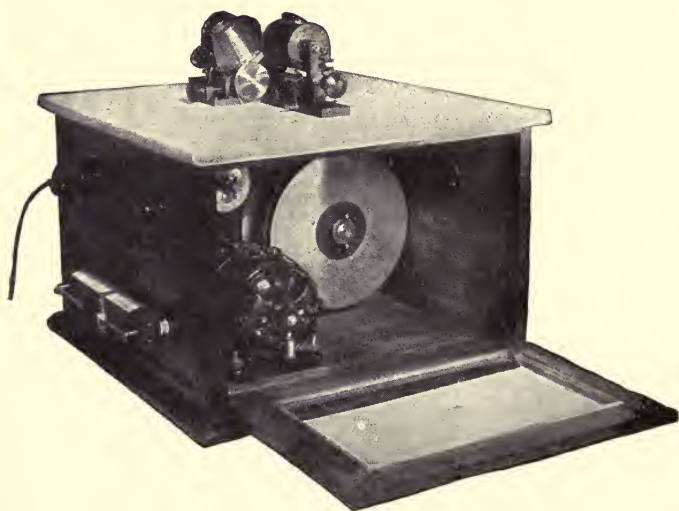

FIG. 122B.

Ruhmer's Moving-Wire-Electrode Arc Apparatus.

trodes causes a variation in the frequency, may be overcome by a simple method of construction, which, however, cannot be described until the completion of certain patents.*

* Under certain conditions good results are also obtained by use of a vacuum tube as discharger.

CHAPTER XVI.

APPLICATIONS OF THE ARC TO TELEPHONY.

HAVING described the three most important methods by which high frequency currents may be produced,* we must now turn to the application of these arc generators to the purpose of transmitters in electric wireless telephony.

The following investigation shows clearly the method of influencing the supply current to the arc.

The Author's H.F. Current Generator.—The author's first successful experiments of this kind were carried out in the summer of 1906, and were described in a communication, dated 23rd October 1906, to the members of the International Conference on Wireless Telegraphy, at that time sitting in Berlin, from which the following extracts are taken :—

“A musical arc in an atmosphere of hydrogen, without a magnetic blast, was used as generator, the supply current being at 220 volts (see Fig. 122). The oscillating circuit consisted of a condenser of about 0.02 microfarad made up of seven Leyden jars, a variable inductance, and the primary of a Tesla transformer. By careful adjustment of the inductance (tuning) a quiet high tension arc of several centimetres length could be maintained between the secondary terminals of the transformer. On observation

* For similar methods see patents Class 21a, B. 43,661, of 17th July 1906, G. 23,377, of 21st July 1906, and G. 23,391, of 25th July 1906; also S. G. Brown, “On a Method of producing Continuous High-Frequency Electric Oscillations,” *The Electrician*, lviii., p. 201, 1906.

with a rotating mirror this arc appeared as a continuous ribbon, like a constant current arc, for the oscillations, which numbered about 300,000 per second, were far too rapid to be distinguished individually. In like manner a cathode ray oscillograph showed two graduated luminous surfaces reaching to equal distances on opposite sides of the zero line. It may be noted that the vacuum tube oscillograph provides a convenient method of testing the tuning of the circuits, and also shows very clearly, by the

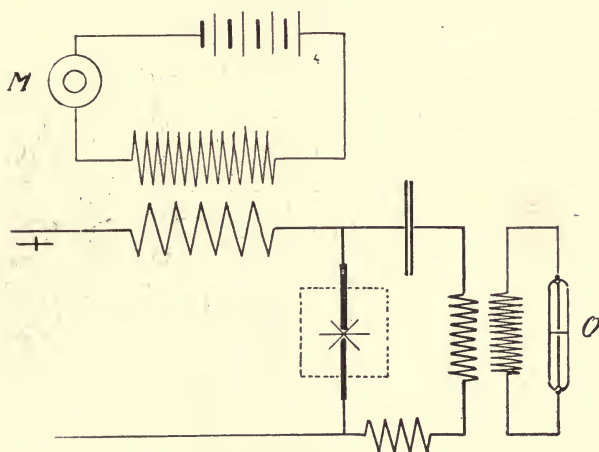

FIG. 123.

Ruhmer's Arc Generator.

amplitude of the motion of the cathode ray, the effects of varying the distance between the electrodes or the strength of current.

“An attempt was made to control this wave generator in the way that a speaking arc may be controlled. For this purpose a transformer was substituted for the choking coil in the supply circuit, and had its secondary connected to a microphone and battery (Fig. 123). The attempt was completely successful, for on speaking into the microphone

the oscillographic tube showed in a rotating mirror a series of bands corresponding to the sound waves, and no longer a uniform ribbon."

Fig. 124, which is drawn from a very weak negative, is a cathode ray picture of the vowel *o* as seen in the rotating mirror.

If the high tension arc described above be supplied with this high frequency current it repeats every word spoken into microphone even more clearly than an ordinary singing

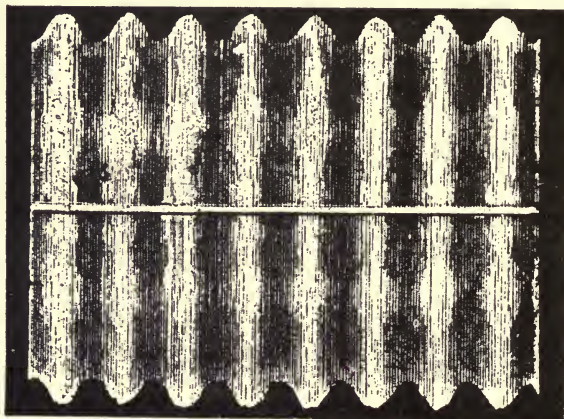

FIG. 124.

Cathode Ray Oscillogram of Vowel *O* as Transmitted by Ruhmer's Apparatus.

arc would under similar conditions. From this experiment there was only one step to the transmission of speech by electrical waves.

The transmitting apparatus is shown in Fig. 125, and the receiver in Fig. 126. A microphonic contact was at first used as detector, but this was soon displaced by an electrolytic cell which worked better.

These experiments, though only carried out in the laboratory, gave astonishingly good results. With aerial wires only 1.5 m. long speech was transmitted loudly and clearly over a distance of 30 metres.

There is no doubt that by the use of longer aerial wires speech could be transmitted over several kilometres.

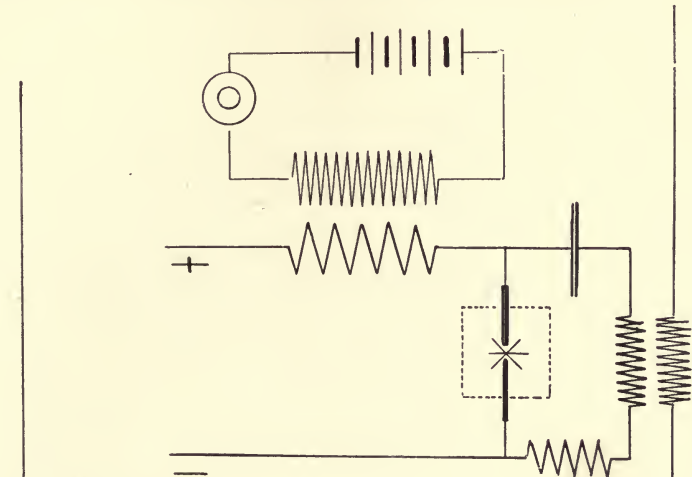

FIG. 125.
Ruhmer's Transmitter.

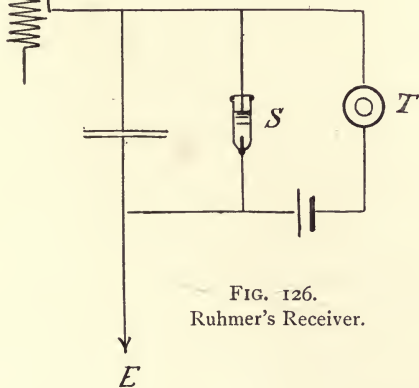

FIG. 126.
Ruhmer's Receiver.

I hope to be able to report on such an experiment immediately.

This experiment was carried out in December 1906,

between two dwelling houses in Berlin, at a distance of about 500 metres from one another. The supply voltage for the arcs was 440 volts, a high tension paraffin condenser of about 0.031 microfarad was used in the jig circuit. The length of aerial wire above the roof was in each case about 20 metres. The transmission of speech was perfect. Of course the microphone current may be made to control the field magnet windings of the supply dynamo, instead of acting directly on the supply current, if desired, as we have seen in the cases of the singing arc and the high frequency alternator.

An attempt to control the arc by the use of a manometric capsule on the gas supply to the enclosed chamber met with little success.

Better results were obtained by microphonic control of a blast electro-magnet, which was either in the main supply circuit, or in an independent one.

Instead of controlling the supply current directly, we may, of course, use any of the methods previously described, whether they consist in an alteration of the intensity or frequency of the radiation. In this connection we may notice particularly Campos' method of placing the microphone parallel to the inductance of the oscillating circuit, Fessenden's system of making it act directly on the aerial wire, and finally the method of altering the strength of the coupling between the closed and open oscillating circuits. We may also cause the sound waves to render the arc alternately active and inactive, a method which the author has tried over short distances with success, and which has enabled him to devise a simple and workmanlike method which leaves little to be desired.

Further data on this subject must be looked for in the technical journals of recent date.

The Nauen Experiments.—The Gesellschaft für drahtlose Telegraphie carried out in December 1906 some similar experiments with a multiple arc transmitter.

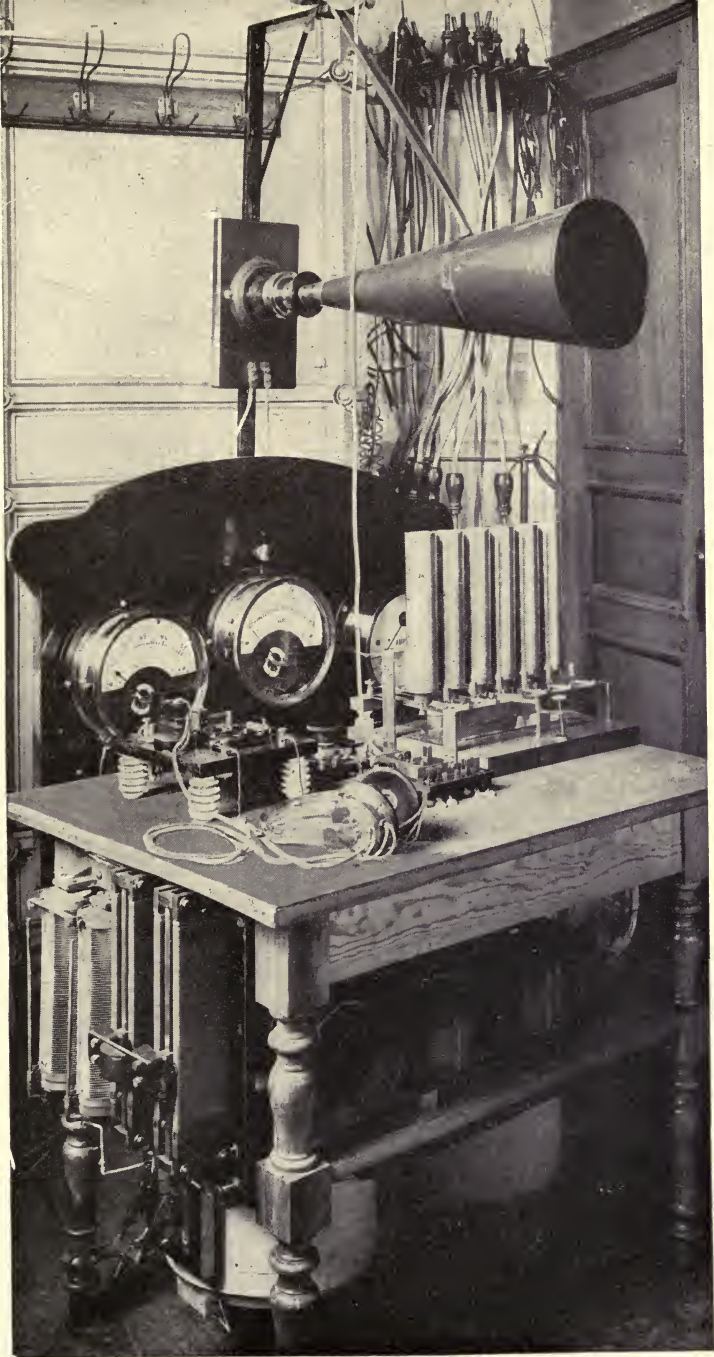

FIG. 127.—Complete Wireless Telephone Apparatus.

Though details have not been published, it appears from the notices in newspapers that the microphone current was superposed on the oscillations in the aerial wire. An electrolytic cell was used as receiver.

A description of the results of an experiment on 14th December, between the Company's Berlin laboratory and their station at Nauen, was given by Sydow at the meeting of the Berlin Electrotechnical Society on 18th December 1906.*

This experiment, however, does not, in the author's opinion, give satisfactory information as to the capabilities of the system, since, as was mentioned in Sydow's paper, the stations were directly connected by a telephone wire, along which the waves may have been propagated.

More certain results would be obtained from an experiment in less favourable circumstances—for instance, across the sea.

Fig. 127 shows the first complete sending and receiving apparatus constructed by the above-mentioned Company.†

On the right stands the six-fold arc generator. The regulating resistance is at the left end, and the choking coils under the table. The microphone, fitted with a funnel-shaped mouthpiece, is placed above.

The receiving apparatus is placed on the left side of the table, and consists of the cell, the telephone, and a coil which serves to tune the circuit to the aerial. Instruments for measuring the currents complete the outfit. The switch for changing over from sending to receiving is placed on the middle of the table.

New Detectors.—To conclude this section we may mention one or two detectors which have not yet been applied to wireless telephony, but which appear to be very suitable for the purpose. They are Hornemann's hot

* *E. T. Z.*, xxvii., p. 1211, 1906.

† See *Technische Rundschau*, xiii., p. 205, 1907.

oxide coherer, and De Forest's audion and mercury vapour detector, details of which may be found in the papers referred to at the foot of the page.*

Coupling.—In all cases it is best to use as weak a coupling as possible in the receiving apparatus between the oscillating circuit and the aerial wire in order to obtain a distinct transmission of speech. A strong coupling gives a louder sound, but on account of the greater damping the purity of the articulation is lost and the sounds become unintelligible.

* *Ann. d. Phys.*, xiv., p. 182, 1904; paper read before the American Institute of Electrical Engineers on 20th October 1906, *Proc. Amer. Inst. E.E.*, xxv., pp. 219-247, 1906; *Electrical World*, xlviii., p. 1107, 1906; *The Electrician*, lviii., p. 216, 1906; see also J. A. Fleming, *Phil. Mag.*, May 1906; British patent, No. 24,850, of 1904, and American patent, No. 803,684, of 1905; and Tissot, *Journ. d. Phys.*, January 1907, and *The Electrician*, lviii., p. 729, 1907; *Electrical World*, xlviii., p. 1186, 1906; *Eclair. Electr.*, l., p. 144, 1907.

Further attempts:—H. Th. Simon, "Telegraphonic Receiver," German patent, No. 147,802, of 1st March 1903, and R. A. Fessenden, "Heterodyne Receiver," *Zeitschr. f. Schwachstromtechn.*, i., p. 116, 1907. See Appendix.



CHAPTER XVII.

THE DUDELL PHENOMENON.

WE have now described the two essentially different methods of producing undamped electrical currents of high frequency. In the one a high frequency alternator is used, and in the other a singing arc. In the distortion of the current curve due to the use of cooled metallic electrodes in the Poulsen and Telefunken generators, both types produce a nearly sinusoidal current which is, of course, the best for the purpose of resonance.

We shall now describe some similar phenomena in which high frequency alternating currents are used, though they are no longer even approximately sinusoidal. These may, however, be used for wireless telegraphy and telephony, and give a considerably larger amount of energy in the oscillating circuit.*

The Phenomena Intermediate between the Stable Arc and the Spark.—Let us commence with the singing arc in our attempt to deduce a definite and comprehensive explanation of the mass of contradictory views, observations, and explanations which have been published on the subject of arc generators.

If, in an arrangement of this type, the supply current is gradually decreased by increase of the series resistance, there comes a time when the amplitude of the oscillation in the condenser circuit becomes so great that during the

* Hahnemann's view (*E.T.Z.*, xxviii., p. 353, 1907), that the methods about to be described are not suitable for wireless telephony, appears to the author to be incorrect.

half period while charging is taking place in the shunt circuit, the current in the arc falls to zero.

This case is shown in Figs. 128 and 129, which are from oscillograms which Mr Duddell has kindly lent me (see footnote, p. 145). We see from these that even near

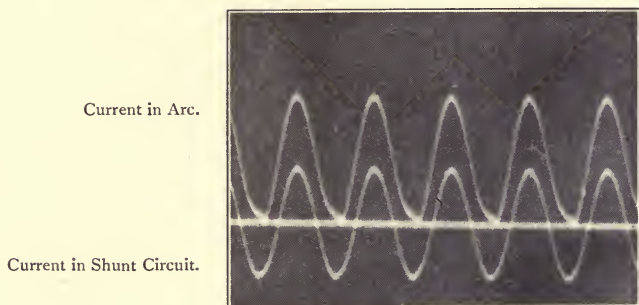

FIG. 128.

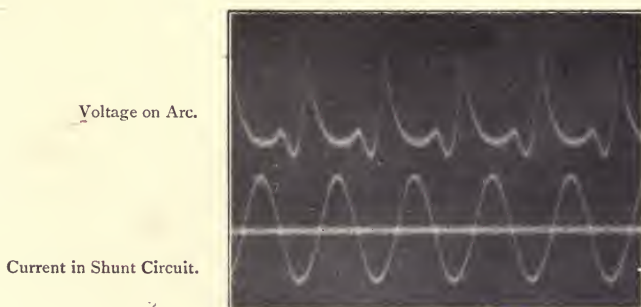

FIG. 129.

The Limits of the Duddell Phenomenon.

the limit of the Duddell phenomenon the current in the oscillating circuit is still approximately sinusoidal.

When the supply current is still further decreased the amplitude of the oscillation increases, and the current in the arc no longer merely touches the zero line but actually

remains at this value for some time, so that on the return swing of the current the arc is struck afresh, and the slower the electricity flows from the source of supply the longer does the capacity take to reach the voltage necessary before this occurs.*

As we have seen in the theoretical discussion on p. 125, the time the arc takes to strike depends on the resistance

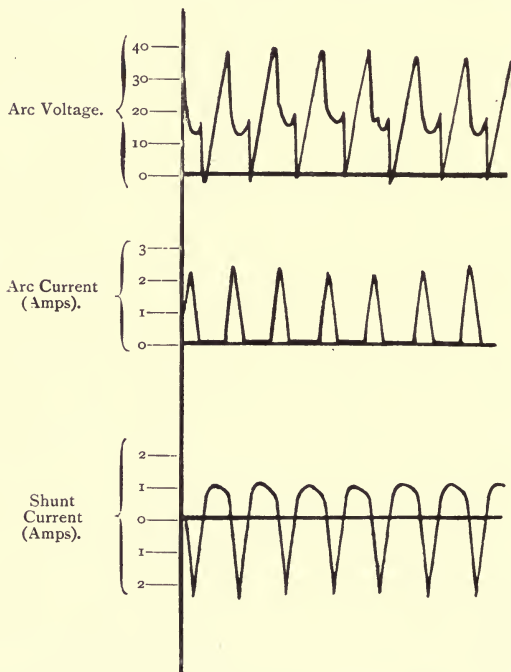

FIG. 130.
Arc giving Forced Vibrations.

and inductance of the supply circuit. The period of the oscillating circuit in this case depends not only on the

* The same happens if too much energy is forced into the oscillating circuit of Duddell's arrangement (see also W. Hahnemann, *E.T.Z.*, xxvii., p. 1090, 1906). The gap between the electrodes must in this case be only a fraction of a millimetre.

constants of the circuit but also on the magnitude of the supply current, and the phenomenon may therefore be called an imperfect or impure Duddell effect.

The current and voltage curves for this case are shown in Fig. 130. It will be seen that the current in the oscillating circuit no longer forms a sine curve.

A singing arc which should have, from its electrical dimensions, a frequency that would give a musical note, gives under these conditions merely a hissing or screeching noise.

One may also deduce this result graphically from Fig. 110 by displacing the point defining the conditions of supply in the direction of less current. As soon as the "resistance line" drawn through the point E becomes a tangent to the characteristic, or more exactly to the diminishing current side of the hysteresis curve at the point considered, the limit of stability of the arc is reached and the arc goes out and remains extinguished until the voltage has risen so much that it strikes afresh.*

We might be inclined to conclude from this explanation that the determining factors are the same in both the pure and impure Duddell phenomena; this is, however, not the case.

The phenomenon we are now considering is in fact a much more general one, being in reality a form of the ordinary spark discharge in which a series of damped wave trains follow one another with great rapidity, but in which the sparking rate is in no way directly related to the frequency of the oscillations produced at each spark. In this impure Duddell phenomenon the second period of the oscillatory discharge does not coincide with the second period of the current in the arc, and therefore there is no continuity in the succession of waves produced.

From this more general standpoint we see that the impure Duddell phenomenon consists in a succession of partial discharges following one another in trains.

* A. Blondel, *Comptes Rendus*, cxl., p. 1680, 1905.

The conditions for the existence of this process are quite different from those for the singing arc. In particular we note that energy passes in this case into the condenser of the oscillating circuit while the arc is extinguished, a circumstance not taken account of in Duddell's condition that dE/dI should be negative. As a matter of fact this condition does not come into consideration at all in phenomena of this kind, as Maisel has shown by both theoretical and experimental researches.*

The nature of the electrodes plays an essentially different part from that which it does in the singing arc, and has no effect on the frequency of the oscillations excited by the intermittent arc.

The above is the author's explanation of the observations, mentioned on p. 146 as being contradictory to the theory of the singing arc, on the appearance in the oscillating circuit of oscillations which are not sinusoidal,† and finally the establishment of the unsuitability of the Thomson formula for calculating the frequency, simply because this formula is in reality applicable to the impure Duddell phenomenon, which, in spite of its resemblance to the singing arc, is essentially different in principle.‡

The possibility of substituting a mercury lamp, in which the quantity $dE/dI = 0$, as Weintraub has shown, with slow alterations of current, for the arc, is also intelligible.§

With the continuous current voltages usually available (from 110 to 550 volts) special means must be employed to render the cathode again active, since mercury vapour rapidly loses its conductivity.||

* S. Maisel, *loc. cit.*

† Corbino, *loc. cit.*

‡ Ascoli and Manzetti, *loc. cit.*, and A. Masini, *Elettricista*, xi., p. 233, 1902; also *Eclair. Electr.*, xxxiii., p. 310, 1902.

§ See, for instance, Valbreuze, *Eclair. Electr.*, xxxvi., p. 81, 1903; *E.T.Z.*, xxiv., p. 831, 1903.

|| Warming the cathode or adding a secondary arc are instances of ways of accomplishing this (Weintraub). See German patent,

The true rôle of the arc in this type of apparatus is still more evident when a high tension direct current is used. Simon's researches, mentioned on pp. 125-128, were made with the purpose of producing a continuous undamped oscillation from a series of separate impulses.*

Simon did not succeed, as we have seen, but only obtained a rapid succession of trains of damped waves.

If the realisation of the necessary conditions offers great difficulties in a mercury vapour arc, it is clear that with an ordinary air gap the difficulty is even greater, since all the hindrances occur in a higher degree.

Elihu Thomson's American patent, No. 500,630 (1892), which has been so frequently, and, in the author's opinion, erroneously, quoted as the precursor of the singing arc, belongs to this group.† Fig. 131 is taken from the patent specification.

It is clearly obvious from both the text and scope of the patent claims that in Thomson's arrangement a spark gap, and not a continuously burning arc, is used. The

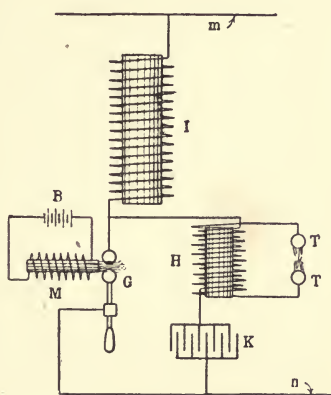

FIG. 131.
E. Thomson's High Frequency
Generator.

No. 173,396, of 27th September 1904, in which a similar arrangement of the author's is shown.

* See Cooper Hewitt's American patents, Nos. 780,999 and 781,000, both of 25th April 1902, and No. 781,603, of 24th September 1902, all three granted on 31st January 1905; *Electrical Review*, xlii., p. 264, 1903; *Electrical World*, xli., p. 326, 1903. Cooper Hewitt gives 3,500 volts as a suitable voltage.

H. Th. Simon and M. Reich, *Phys. Zeitschr.*, iv., p. 364, 1903, and H. Th. Simon, *Phys. Zeitschr.*, iv., p. 737, 1903.

† Application dated 18th July 1892, granted 4th July 1893. See also Elihu Thomson, *The Electrician*, xlvi., p. 477, 1901, lviii., p. 542,

electro-magnet, shown in Fig. 131, which, according to Thomson, is otherwise quite unnecessary* for satisfactory working, serves exactly the purpose of preventing the series of discharges becoming an arc.

Hence there can hardly be a doubt that fundamental idea of the patent deals with a disruptive discharge. Whether Thomson in these experiments really obtained a succession of single impulses, or, which appears much more likely, a series of damped wave trains, must be left undecided. It is also not impossible that Thomson may have actually observed the pure Duddell phenomenon, in which case, however, he did not recognise the differences in action under different conditions, and only described one of the possible processes, which happened to be one the principle of which is different from that of the singing arc.

The difficulties which we have noticed that arise in attempting to maintain the necessary conditions for a disruptive discharge may be partially overcome by special artifices as Simon has shown.†

1907; *Electrical Review* (London), lix., p. 986, 1906; *E.T.Z.*, xxviii., pp. 304, 305, 1907; R. A. Fessenden, *The Electrician*, lviii., pp. 675 and 710, 1907. Fessenden, in his American patent, No. 730,753 (application 9th April 1903, granted 9th July 1903), expresses an exactly similar view of the Thomson arrangement as that given above by the author (see p. 2, lines 86-88)—“In the Thomson patent the oscillation frequency is identical with the discharge frequency.” His standpoint is all the less comprehensible as he proceeds to identify the Thomson with the Duddell phenomenon. Further, “The Arc in Wireless Telegraphy,” *The Electrician*, lviii., p. 374, 1906; and J. A. Fleming, *The Electrician*, lviii., p. 733, 1907; also L. H. Walter, “The Arc and Spark in Wireless Telegraphy,” *Electrical Engineering*, 7th February 1907.

* See American patent, No. 500,630, p. 1, lines 73, 74—“At M is represented a powerful magnet which is not always, however, necessary, but the purpose of which is to break any arc between the balls at G. It may sometimes be replaced by an air jet;” and *The Electrician*, li., p. 542, 1907—“Neither was the dying spark suddenly blown out by a magnet or air blast, because in the course of my experiments I found that neither of these adjuncts was necessary.”

† H. Th. Simon, *Phys. Zeitschr.*, iv., pp. 372 and 740, 1903.

One of these methods consists in causing so great a transference of energy from the oscillating circuit to the aerial wire at each discharge that the jig is very suddenly damped out, and the air gap returns very rapidly to its non-conducting state.

Unsymmetrical Electrodes.—A still more simple and certain method of attaining the same end is to use unsymmetrical spark gaps which act as valves, since they require a greater voltage in the one direction than in the other,* if one arranges the voltage so that the discharge of the capacity occurs at the lower voltage, and hence the voltage of the next half wave is not sufficient to cause a new spark. The use of these unsymmetrical spark gaps has been very frequently suggested,† and has been carried out by Simon.

Righi, for instance, used, in his experiments in 1901, a Geissler tube which had a flat cathode and a pointed anode as spark gap (see p. 154). The current curves which he obtained by means of a Braun's oscillograph show clearly that he actually obtained a series of single impulses, which followed each other in the way to be expected from theory on consideration of the constants of the supply circuit, and of the oscillating circuit.

It appears not impossible that a dissymmetry of this kind may also arise through the heating of one electrode, and the cooling of the other. Simon's explanation of the action of Poulsen's generator depends on this hypothesis,‡ which, however, is not in agreement with the author's results described below.

* A valve may also be put in series with the spark gap (see for instance A. Blondel, British patent, No. 15,527, of 1902, p. 5, lines 17, 18; also H. Th. Simon, *E.T.Z.*, xxviii., p. 317, 1907).

† R. A. Fessenden, American patent, No. 706,741, application 5th November 1901, granted 12th August 1902; A. Blondel, British patent, No. 15,527, of 1902, applied for 11th July 1902, completed 11th April 1903, granted 11th July 1903, p. 5, lines 17 and 38, 39; H. Th. Simon, *loc. cit.*, and German patent, No. 156,364, of 26th March 1903.

‡ H. Th. Simon, *E.T.Z.*, xxviii., p. 317, 1907.

A very large number of proposals for the control by sound waves of a disruptive discharge transmitter are described in Blondel's British patent, No. 15,527, of 1902.*

We must also notice here the difference between the process employed in this system of wireless telephony and the Duddell phenomenon, thus (p. 5, lines 27-30), "It may be noticed that the appearance of Fig. 2 is analogous to that of the well-known arrangement and patent of Duddell, No. 21,629, of 1900, on the musical arc: *but an essential difference is the employment of a disruptive discharger instead of an arc.*"

In the methods so far described for the production of undamped electrical oscillation by means of an arc or spark we have dealt with a phenomenon which only occurs under certain definite conditions in regard to the constants of the coupled circuits. In a certain sense the capacity plays the most important part in the action. Since the choking coil in the supply leads allows only slow variations in the supply current to take place, the charging of the condenser takes energy from the arc or spark gap, so that the current is considerably diminished (Duddell phenomenon), falling under certain circumstances momentarily to zero (limit of the Duddell phenomenon), or remaining at zero until the voltage across the gap has again risen sufficiently to cause a discharge (impure Duddell phenomenon, disruptive discharge process).

* See also A. Blondel, German patent, No. 160,880, of 17th August 1902.

CHAPTER XVIII.

FORCED VIBRATIONS.

IN conclusion we shall describe still another group of methods in which, unlike those previously mentioned, the arc itself must be considered as the actual generator, and in which the oscillations in the shunt circuit are merely forced.

Forced Vibrations.—This process will be most easily understood if an apparatus is considered in which the discharge gap is supplied with alternating and not direct current. Clearly in this case we shall have the greatest oscillations in the shunt circuit when its natural period is the same as that of the supply current, *i.e.*, when there is revibration (resonance) between the impressed and free vibrations. An arrangement of this kind would have no practical value if it were necessary to produce the high frequency supply current mechanically—by means of an alternator, for instance—since the secondary circuit would then be unnecessary. These variations or interruptions of the direct current supply may, however, be caused in a very simple manner by the application of a magnetic or air blast to the spark gap.

De la Rive has observed* that an otherwise quietly burning direct current arc, when placed in a magnetic field gives out a loud noise, “like the hissing of the steam blown off from a locomotive.”

* De la Rive, *Pogg. Ann.*, lxxvi., p. 281, 1849.

This observation indicates that relatively rapid oscillations are taking place in the arc, and, in fact, these may become so great that the arc is extinguished.

This rapid succession of extinctions and strikings of the arc in a magnetic field has been since observed by other experimenters. Blondel (1893), for instance, gives 3,000 to 4,000, and Abraham (1899) as much as 100,000 per second.

Fitzgerald suggested that by such a rapid succession of interruptions of an arc it might be possible to produce high

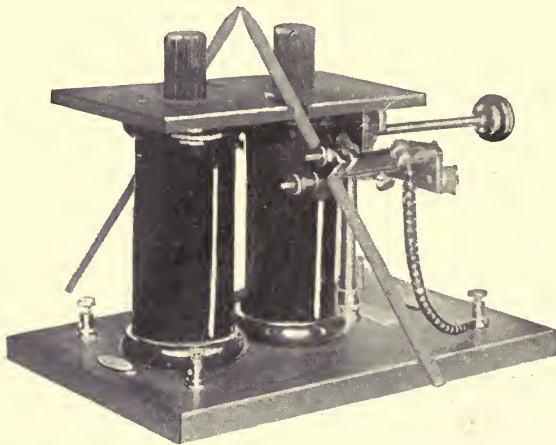

FIG. 132.

Ruhmer's Arc Interrupter.

frequency currents. This is particularly interesting, since it was from this point of view that Duddell was investigating the influence of a magnetic field on the arc before his discovery of the musical arc. Since, however, the interruptions were too irregular no result was obtained.

The author has found that the regularity of the interruptions may be much increased if a parallel circuit, whose natural period is the same as that of the action in the supply circuit, is connected to an arc controlled by a magnetic or

air blast.* Still more satisfactory results were obtained when the action of the blast was in time with the oscillations, a condition most easily attained by putting the magnet in series with the arc. We have thus to do with an arrangement which is, to say the least, very like that used by Poulsen in his arc generator (see Fig. 117).

The Arc Interrupter.—The author's arc interrupter, invented in 1903, depends on this principle (see Figs. 132 and 133); it was shown in the Exhibition of Electrical Novelties in Berlin † (22nd to 27th November 1904), and described in the *Electrotechnische Zeitschrift*, xxvi., pp. 382, 383.

The author clearly indicated the importance of this apparatus as a generator of high frequency currents at a demonstration before the Leipsic Electrotechnical Society, on 12th January 1905. ‡

Since the supply voltage controls the speed of increase of the current, and the strength of the magnetic blast the

* H. Mosler later described a similar arrangement, and noticed that resonance must occur between the electro-mechanically excited oscillations of the arc and the current in the parallel circuit (*E.T.Z.*, xxviii., pp. 142 and 304, 1907).

† At this Exhibition this apparatus was shown both as interrupter for a 30 cm. induction coil (the primary winding of which in series with a condenser formed the oscillating circuit), and also as a generator of high frequency alternating currents.

‡ See *E.T.Z.*, xxvi., p. 383, section 1 below: "To show that this interrupter serves also for the production of high frequency currents an impedance coil was supplied from it. The rate of interruption was in this case about 20,000 per second, but could, however, be increased by alteration of the natural period of the oscillating circuit to 400,000 per second, as was shown by a cinematographic record. *By this means the hitherto insoluble problem of the production of continuous oscillations of high frequency has been solved in a very simple manner.*" See also *Mechaniker*, xiii., p. 13, 1905; A. Prasch, "Die Fortschritte auf dem Gebiete der drahtlosen Telegraphie," iv., pp. 178 and 266, 1906; further, A. Righi and B. Dessau, "Die Telegraphie ohne Draht," 2 auflage, pp. 405, 406, 1907.

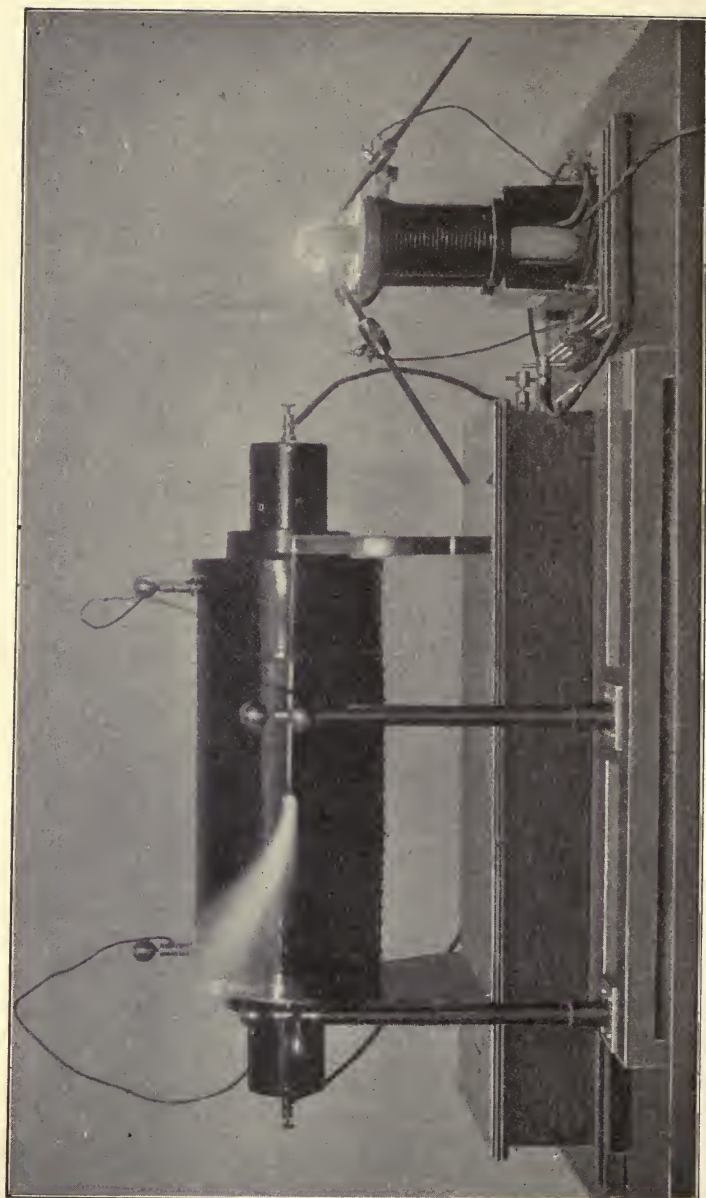

FIG. 133.—Ruhmer's Arc Interrupter in Action.

rapidity of its fall, both factors must be taken into account in order that the parallel circuit may be subjected to the impulses at the right moments.

By means of a high tension arc in air fitted with the above-described apparatus, high frequency alternating currents suitable for use in wireless telegraphy and telephony have actually been produced.

In contrast to the Thomson arrangement, in which, under proper conditions, free oscillations take place in the shunt circuit, this arc interrupter causes only a forced oscillation by the action of the varying magnetic blast. While in the one case the independently excited magnetic blast serves mainly to prevent the formation of an arc, and may be left out under certain circumstances without harm, in the arc interrupter it plays the principal part, and without it there would be no excitation of the oscillatory circuit.

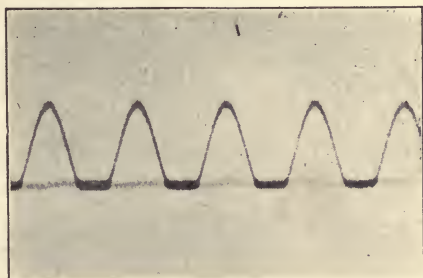

FIG. 134.
Oscillograms of Forced Vibrations.

Finally, we must mention, though it seems almost superfluous to do so after what has been said, that of course the arc interrupter does not conform with the conditions for the singing arc. Experiments show, for instance, that rapid oscillations may be produced when soft-cored carbons are used, for which, as Frith and Rodgers* have shown, dE/dI is positive.

If the Duddell phenomenon is analogous to the ordinary organ pipe, the arc interrupter corresponds to the reed pipe, in which the column of air is forced to vibrate synchro-

* Frith and Rodgers, *Phil. Mag.*, vol. xlii., p. 407, 1896.

nously with the tongue. And just as in the reed pipe the vibrations of the air column react on the reed, so do

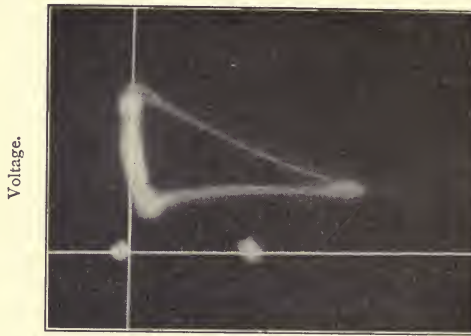

Current.

FIG. 135.

Characteristic of Short Arc with Forced Vibrations: Complete Extinctions of Short Duration.

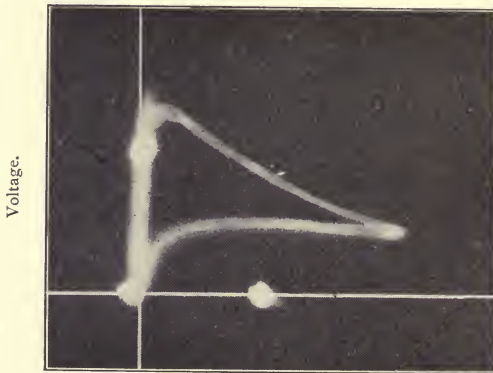

Current.

FIG. 136.

Same as 135, but Longer Arc; Voltage also falls to zero in this case. Times of Extinction Longer.

the currents in the oscillatory circuit react on the arc interrupter.

The method we have just described has the great

advantage over previous ones that it is possible by its means to cause oscillations of almost any desired energy.*

In the explanation given above of the arc interrupter, we have assumed that the blast magnet causes a complete extinction of the arc. The current must therefore not only fall to zero, but must remain at that value for some time before it rises again. That this is actually the case is shown in the typical arc interrupter current curve of Fig. 134, taken oscillographically with about four hundred interruptions per second.

Even if the action of the magnet is so weak that it does not cause a complete extinction of the arc, it is probable that a periodic oscillation of the latter is produced, since the connection of the windings of the electro-magnet in series with the arc must produce a mutual interaction.†



Current.

FIG. 137.

More Unfavourable Conditions.

By making the process relatively slow it is possible to prove the existence of an oscillation of this kind above the zero line by means of a Braun's tube. Unfortunately it is very difficult, indeed almost impossible, to observe high frequency current curves with an ordinary oscillograph with an accuracy sufficient to enable a distinction to be made between a complete interruption and a partial oscillation of the arc.

* See also W. Hahnemann, *E.T.Z.*, xxviii., p. 353, 1907.

† M. Reithoffer denies the possibility of the production of undamped waves by such an action, *E.T.Z.*, xxviii., p. 308, 1907.

Characteristic Curves of Various Types of Discharge.— If, however, we adopt Simon's arrangement, we can obtain a photographic record of the dynamic characteristic. In this method the cathode ray is acted on by magnetic fields at right angles to one another, one of which is due to the current, and the other to the voltage, in the oscillating circuit. The cathode ray strikes a fluorescent screen, producing a spot of light which describes the characteristic curve since each point is defined by the current and voltage at the moment. The motion of the spot is so rapid that the curve appears steadily on the screen, and may be photographed.

Figs. 135 to 137 show some characteristics of an arc interrupter taken by the author. The axes of co-ordinates may be determined by the position of the points seen in the figure. This method is applicable to currents of any frequency.

The zero point of the current flowing in the voltage coil is displaced to the left since the deflection is caused electro-magnetically; it may also be produced electro-statically as Wehnelt has shown.

Figs. 135 and 136 correspond to cases in which the current falls to zero, and there is a complete interruption and extinction of the arc. Fig. 135 was taken with a short, and Fig. 136 with a long arc; the conditions being otherwise similar. In the latter, as the characteristic clearly shows, the voltage also fell momentarily to zero.

Fig. 137 is a complicated curve taken under unfavourable conditions of the arc interrupter. Without going further into it at present we may notice that there was a complete extinction of the arc in this case.

In addition to these curves similar ones were taken with comparatively short arcs. One of these has been transferred to the diagram, Fig. 138, in which it is marked 1; it does not touch the axes at any point, and the lowest value of the current is at most 1 ampere. Curves 2 and 3 correspond to the characteristics in Figs. 135 and 136.

For purposes of comparison the characteristics of the singing arc (marked D) and of the Poulsen generator (marked P) are included. It should be noticed that the steepness of the Poulsen curve, as compared with those taken from arcs in air, is due to the atmosphere of hydrogen in which the arc burns.

It may be remarked that under the conditions adopted by the author for the observation of the Poulsen generator,

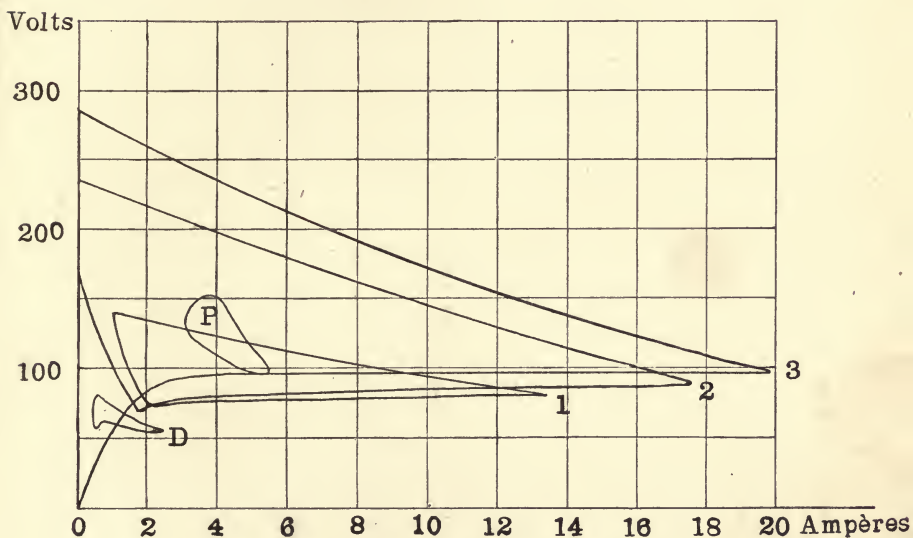

FIG. 138.

Characteristic Curves of the Duddell, Poulsen, and Arc Interrupter Currents.

a characteristic corresponding to a complete extinction of the arc, *i.e.*, one which touched the axes of co-ordinates, was only obtainable just before the arc went out altogether, and could not be maintained for any length of time.*

These observations in no way exclude the probability

* This observation does not agree with Simon's earlier theory of the Poulsen generator (see p. 155).

that the Poulsen generator acts by producing a forced vibration in the shunt circuit. A similar explanation has been given by Benischke of the action of a very similar arrangement.*

The author has given his opinions on the subject in letters to the technical papers from which the following paragraphs are taken: †—

“Poulsen apparently only used the magnet, at first, to fix the position of the ends of the arc.

“It was only later, as I gather from the progress of the discovery, that he strengthened the magnetic field in order to maintain the arc active in spite of a greater supply of energy, since the Duddell phenomenon no longer occurs with large currents, even with cooled electrodes and a hydrogen atmosphere. The arc then becomes stable and hence inactive. A powerful magnetic, or air, blast which breaks the arc, is then necessary in order to excite the oscillating circuit.

“Poulsen thus, whether knowingly or unknowingly is of no consequence, superposed his hydrogen atmosphere on my arc interrupter.

“I agree with Herr Benischke that after Herr Poulsen's demonstration to the Electrotechnical Society, we must come to the conclusion that the apparatus shown was only my arc interrupter working in an atmosphere of hydrogen.”

This explanation is, however, based on the erroneous assumption that the Poulsen generator acts through interruptions. As we have seen above, and as Benischke has also noticed, ‡ it is of no consequence whether the interruption is complete or not, or whether the current reaches a zero value, for the real characteristic of the method is the

* G. Benischke, *E.T.Z.*, xxvii., p. 1212, 1906.

† E. Ruhmer, *E.T.Z.*, xxviii., p. 69, 1907.

‡ G. Benischke, *E.T.Z.*, xxviii., 1907.

production of forced oscillations in the shunt circuit through the action of the external agencies.*

The Mercury Arc.—Finally, we must mention that in an arrangement of this kind a mercury arc may be used instead of an ordinary arc.

As long as the blast electro-magnet is required only for the purpose of causing oscillations and not as an interrupter, ordinary supply voltages may be employed. With stronger action, when the arc is actually extinguished, it is necessary to use some method of increasing the activity of the cathode, and for this purpose a high tension continuous current is most suitable.

In conclusion, we shall describe shortly an apparatus of Vreeland's for the production of undamped oscillations.† In this a mercury lamp is used which has a mercury cathode and two anodes. The connections shown in Fig. 139 are only diagrammatic, as the electro-magnets are in reality placed vertically to the plane through the anodes. When the apparatus is in working order the current flows practically equally to both anodes; the slight differences between them cause, however, oscillations and hence variations in the field of the electro-magnets. This results in the current ray being pulled over towards one or other of the anodes, and at once the field of the magnet connected to this side is strengthened, and the current is driven back to the other anode which strengthens the field of the other

* G. Benischke, *E.T.Z.*, xxviii., p. 354, 1907. Benischke here makes the remark that a similar phenomenon must arise through the magnetic coupling of the secondary oscillating circuit to the arc circuit if the arc is used as an oscillation generator. As a matter of fact oscillations may be produced by an arrangement of this kind, as the author's experiments have shown; while in Duddell's apparatus, where the condenser is the oscillation producer, the substitution of a magnetic coupling for the electric one is not possible.

† K. Vreeland, *The Electrician*, lviii., p. 685, 1907; and *E.T.Z.*, xxviii., p. 276, 1907.

magnet. The result is an oscillatory current of high frequency in the main circuit.

A transmitter for wireless telephony is shown connected to this generator in Fig. 139.

The voice controls the electric radiation by means of a microphone whose current alters the coupling between the primary and secondary systems.

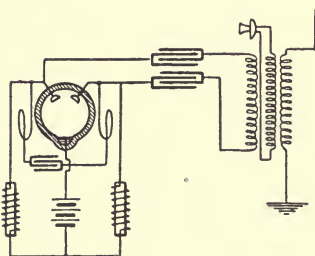

FIG. 139.

Vreeland's Twin Electrode Mercury Vapour Discharger.

The Function of Open-Circuit Wireless Telephony.

— Electric wave-telephony forms a most valuable extension of wireless telegraphy, since stations fitted for the latter may easily be adapted to the former, but it is not

likely that it will to any extent take the place of wire-telephony, at least for some time to come, since a rapid change-over from speaking to hearing is not possible. A listener at a wireless telephone must wait patiently until the speaker has finished, and then must change over his switch before he is able to answer.*

With the oscillations of small intensity which it is possible to produce by means of the human voice, it appears unlikely that great distances will be bridged. On this account the field of electric wireless telephony seems at present to correspond with that of light-telephony.

Without doubt the new method of communication will prove useful by its great suitability for such purposes as communication between ships and for military work.

* At the same time it is possible that wireless telephony will have a considerable influence on the development of wire-telephony. We may notice, for instance, the problem of multiplex telephony, the solution of which may lie in the adoption of wireless methods.

Electric wave-telephony possesses all the advantages and disadvantages common to every method of communication by electric waves. One of its advantages is that the stations need not be in sight of one another, while its main disadvantage is the difficulty of maintaining absolute secrecy and freedom from interruption.

If one compares wave-telephony with light-telephony it is seen that the advantages of the one are the disadvantages of the other, and *vice versa*. Thus in a case where it is desired to send the voice in a certain direction only, a beam of light is preferable; while, on the other hand, the condition of the atmosphere, so important in light-telephony, is of practically no consequence in wave-telephony.

CHAPTER XIX.

CONCLUSION.

WE have seen in the foregoing how the problem of the wireless transmission of human speech has been solved. There are two principal and very similar methods:—light-telephony and wave-telephony, the former almost as old as the telephone itself, and the latter a child of most recent growth.

Great advances may be expected in the latter since it is still in a very early stage of its development, and there can be no doubt that, as on every side energetic attempts are being made to improve it, its progress from day to day must be very rapid.

Although the principle of the method has been obvious for a long time, it is only quite recently that theory has been converted into practice.

While it is only a few months ago that the great inventor Edison rightly gave to the question, "What is the outlook for wireless telephony?" the answer, "It does not exist," we are already in the position to transmit speech wirelessly over several kilometres. Indeed Fessenden and Tesla have already, in somewhat fanciful manner, prophesied that radiotelephony will be the telephony of the future.

"With proper apparatus telephonic communication will be carried on with ease and precision to the greatest terrestrial distances, and very soon it will be possible to speak across an ocean as clearly as across a table." So prophesies Tesla in the *English Mechanic*. Ayrton's picture

of the future would then have nearly attained its fulfilment:—

“The day will come, when we are all forgotten, when copper wires, guttapercha covers and iron bands are only to be found in museums, that a person who wishes to speak to a friend but does not know where he is, will call with an electrical voice which will be heard only by him who has a similarly tuned electric ear. He will cry, ‘Where are you?’ and the answer will sound in his ear, ‘I am in the depth of a mine, on the summit of the Andes, or on the broad ocean.’ Or perhaps no voice will reply, and he will know that his friend is dead.”

Returning to accomplished facts, we must admit that, if even in only a limited degree, wireless telephony will be of service to mankind.

APPENDIX.

RECENT ADVANCES IN THEORY AND PRACTICE.

BY JAMES ERSKINE-MURRAY, D.Sc.

Latest News.—Since the publication of Mr Ruhmer's book in the spring of this year (1907), a good deal of matter of both theoretical and practical interest in wireless telephony has been published. Of the latter, perhaps the most interesting item of news is the recognition of the practical value of wireless telephony as a means of communication in warfare by the United States Government. The fact that, after an exhaustive test, twenty-eight sets of wireless telephones have been ordered from the American Radiotelephone Company for use in the navy, is a proof that wireless telephony has already a commercial value. The tests took place on board the battleships "Connecticut" and "Virginia," to which speech was transmitted from the "Tennessee" and "Kentucky" at distances of from eleven to twenty-five miles in the autumn of this year. The articulation was clear and satisfactory even up to this distance.

Telephony has, of course, some important advantages over telegraphy, particularly as regards its use by unskilled operators and as to speed. It has the disadvantage of being rather more liable to error, since the words are not spelled out letter by letter as in telegraphy, and in that no form of automatic record is practicable.

One advantage of wireless telephony over wireless

telegraphy is that atmospheric discharges do not interfere to nearly as large an extent. The reason for this is that there is no difficulty in distinguishing the voice even though there is a very considerable amount of extraneous noise going on—it is done every day in ordinary and in telephonic conversations. The conditions are not the same in telegraphy, where, if a recorder be used, every electrical impulse arriving at the receiver makes its mark, whatever be its origin. If a telephone be used as a telegraphic receiver, strays (atmospheric discharges) may sometimes be distinguishable from signals, particularly if the sparking of the transmitter is so rapid and regular as to give out a definite tone by which the signals may be differentiated from the strays. The distinction is not, however, so easy as in telephony.

Among recent achievements in wireless telephony may be mentioned Professor Fessenden's experiments in America, of which details are given below, and the Poulsen Company's demonstration of the transmission of speech over a distance of about fifty miles in the neighbourhood of Berlin. Details of the latter have not been published, but there is little doubt that the arc is used as H.F. current generator, and that the control is by means of a microphone inductively coupled to the supply circuit. A successful demonstration of wireless telephony between ship and shore was given by the De Forest Company at a regatta on Lake Erie this year, when communication was maintained all day over a distance of about five miles.

Recent Advances in Theory.—Dr Barkhausen's monograph on the production of electrical vibrations, published at Leipsic in July, contains a very full and complete account of the theory of the various methods of producing electrical vibrations, and in particular of the vibrating arc. His curves, showing the different types of oscillation which have been alluded to in Chapters XIII., &c., indicate very clearly the passage of one type into another, and the mathematical analysis which accompanies them expresses

very exactly the results of experiment. Among other deductions, the following are of special interest to wireless telephonists:—(1) “The energy given to the oscillations increases with the square of the difference between the voltage at which the arc strikes and that at which it burns.” Another proposition of importance is that (2) “The condition for a high frequency, and also for the production of oscillations which are capable of inducing resonance, is that the arc shall only remain extinguished for a very short time.” For practical purposes, we have the statement that (3) “High frequency oscillations which are capable of exciting resonance and at the same time of transmitting considerable energy, are only obtained when the striking voltage attains a high value in as short a time as possible (a small fraction of the total period) after the extinction of the arc.” Hence the advantage of using metal electrodes which cool rapidly, and of a magnetic or air blast which cools the electrodes by causing a draught and blowing away the ionised gases, or of an atmosphere of hydrogen, which has a very high rate of diffusion. These actions are more particularly important in that they ensure that each time the arc is struck it shall be at a new place on the electrode, which is still cold, and where there is as yet no column of ionised gas. To the conditions given above must be added that for the stability of the oscillation, which is that (4) “The striking voltage, after it has very quickly risen to a high value, must not further increase.” Another important observation is that (5) “The arc should not be allowed to strike in the reverse direction, since the conditions are then such as conduce to an irregular action.” This phenomenon may be prevented by the use of unlike electrodes or by heavy damping.

Signor Alfredo Montel has published an account of the calculation of a radio-telegraphic station using persistent waves, in *L'Elettricista* (Rome), No. 13 of 1907. His results, which include actual numerical calculations, are, of course, applicable to a telephonic station. The

paper is, however, too full of detail to render a short abstract of any value. Those who are interested should therefore refer to the original.

Details of Professor Fessenden's Work.—In conclusion, I shall give some details of Professor Fessenden's recent inventions, with extracts from a memorandum which he has kindly sent me, and from an independent expert's report on some tests of his wireless telephone.

Heterodyne Receiver.—One of the most interesting of Professor Fessenden's many inventions is what he has called the "Heterodyne" receiver, which is an ingenious adaptation of the ordinary Bell telephone receiver to the purposes of wireless telephony. He was led to its invention by a consideration of the great inefficiency of even the most sensitive of detectors, and of their insensibility as compared with a telephone. Thus, while a liquid barretter or a magnetic receiver will give an indication with between $\frac{1}{100}$ and $\frac{1}{1000}$ of an erg, an ordinary telephone will produce an audible sound with less than $\frac{1}{1000000}$ of an erg.

The Heterodyne receiver consists of two small coils of wire, one of which is wound round a fixed core of very fine iron wires; the other, whose plane is parallel to that of the first, is attached to a mica diaphragm. A high frequency current from a local source is maintained in the first coil, while the second is traversed by the current from the receiving aerial. The frequency of the local current is kept constant and within a few per cent. of the normal frequency of the transmitter, and, therefore, of the received current. Thus, when the frequency or amplitude of the transmitted current is altered by the action of the voice in speaking, the mechanical force between the two coils of the receiver varies in like manner, and the result is a reproduction of the sound by the mica diaphragm.

An important point, noticed by a telephone expert at a test of Professor Fessenden's apparatus, is that, in wireless telephony, there does not appear to be any distortion of sounds with increase of distance, as is the case in all line

wires. It should therefore be possible to telephone wirelessly to very much greater distances than can be attained by wire as soon as proper means have been devised for the radiation of a larger amount of energy.

Historical Notes by Professor Fessenden. — In December 1899 a rotating commutator was constructed for me by Mr Brashear, according to my design. This ran in oil and gave between 5,000 and 10,000 breaks per second.

This was not tested for wireless telephony until October and November of 1900, on account of other apparatus not being ready. In November 1900 speech was for the first time transmitted by electro-magnetic waves over a distance of one mile at Rock Point, Md.

Articulation was not very good, although understandable, on account of the hissing noise due to irregular sparks. This was partly overcome by using a discharge gap consisting of a platinum-iridium sheet and an aluminium point.

The possibility of generating waves by a high frequency alternator was investigated, with favourable results, and the design of a high frequency alternator begun. (See U.S. patent, No. 706,737, filed 29th May 1901.)

In the meantime the Elihu Thomson singing arc was investigated. It was found that high frequencies could be generated by it, but that the intensities and frequencies varied greatly. The arc was used under compression. (See U.S. patent, No. 706,741, filed 5th November 1901.)

It was found that, by introducing resistance and making other changes, a constant frequency and intensity could be obtained. (U.S. patent, No. 706,742, filed 6th June 1902, figure 10, and the divisional case 730,753, filed 9th April 1903, more particularly page 2 of the latter.)

Successful results having been obtained, the method was patented and published. (See U.S. patent, No. 706,747, filed 28th September 1901.)

In 1903 the first high frequency alternator was com-

pleted, and much better results were obtained as regards articulation.

About the middle of 1906 the difficulties from the hissing of the arc had been practically overcome, and telephonic communication was being maintained between shore and a small schooner up to distances of twenty miles from shore.

In the fall of 1906 a high frequency alternator giving

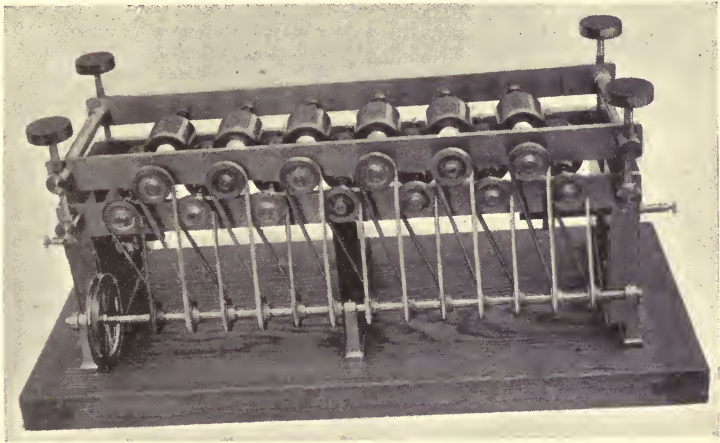

FIG. 140.

Multiple Arc Apparatus with Rotary Electrodes,

frequencies up to 80,000 was completed, and this also was used in communicating to the schooner.

Meantime telephonic transmitting and receiving relays had been designed and completed and a station equipped at Plymouth, eighteen miles by road or eleven miles on a straight line from Brant Rock, and speech was being transmitted from a local wire line to the wireless station, and there relayed wirelessly to Plymouth, and then relayed out again to another local circuit.

Apparatus tests were made in the presence of engineers

about this time. For a report of the result of such a test see *American Telephone Journal* editorial, page 75, dated 2nd February 1907.

A test was made by a representative of the Bell Telephone Company (see below).

Lately we have been communicating between Brant Rock and another station which we erected in New York City, a distance of nearly two hundred miles. In these latter tests about two hundred and fifty watts were used.

For other work in wireless telegraphy see U.S. patent, No. 793,649, filed 30th March 1905.

There are a number of patents on multiplex telephony, *i.e.*, sending and receiving a number of messages simultaneously from the same station, but these have not been published yet.

We have recently succeeded in constructing and operating high frequency alternators giving an output of more than two kilowatts at a frequency of 100,000 cycles, and have under construction some turbine-driven alternators giving about twenty kilowatts output at a frequency of about 200,000 cycles.

You may be interested to have a description of one of our designs for ship use. This consists of a field disc six inches in diameter with three hundred teeth. The gap is approximately one-eighth of an inch, and there are two armature discs. This is driven by a small De Laval turbine five inches in diameter and without any governor, the governing being done by an electrically operated reducing valve. The speed is 30,000 revolutions per minute. The resistance of the armature is two ohms, and the voltage one hundred and fifty volts to two hundred volts.

The whole of the rotating parts are on a gyroscopic mounting, so that when used on ship-board the rolling of the ship will not cause the shaft to bend too much.

The operation of the plant is very simple, the operator having no electrical connections nor spark gaps to look after, but requiring merely to open a valve and bring his

dynamo up to speed. When this is done he is at liberty either to telegraph or telephone by merely throwing over a switch.

This apparatus produces no interferences on neighbouring stations for obvious reasons, as the output is constant, and what is known as the "scissors system" of sending is used.

WIRELESS TELEPHONE TESTS AT BRANT ROCK AND PLYMOUTH, MASS.

(BY AN EXPERT OF THE BELL TELEPHONE COMPANY.)

Excerpts from a Description.

On Friday, 21st December 1906, I was present at a test of wireless telephony, between stations at Brant Rock, and Plymouth, Mass. The air-line distance between these stations is eleven miles, passing almost entirely over water. The tests were conducted by the National Electric Signaling Company, under the personal supervision of Professor R. A. Fessenden.

There were also present Professor Elihu Thomson of the General Electric Company, and Messrs Keating and Davis of the Associated Press.

TRANSMITTING APPARATUS AND CIRCUITS.

The transmitting station was located at Brant Rock, employing as a radiating antenna the 400-foot steel tower used in transatlantic signalling. In addition to the tower proper, a sort of skeleton umbrella, composed of four hollow cylinders of wire, depended from the top.*

The radiating antenna is connected to ground through a tuning inductance, the secondary of a high frequency transformer, and a granular carbon button, which is either

* See Handbook of Wireless Telegraphy, by J. Erskine-Murray, p. 170 (Crosby Lockwood, London, 1907).

used directly in a transmitter, or as an element of a telephone repeater. In the primary circuit of the transformer is connected the high frequency alternator.

I consider this alternator a most remarkable piece of apparatus. It is a complete controversion of the fre-

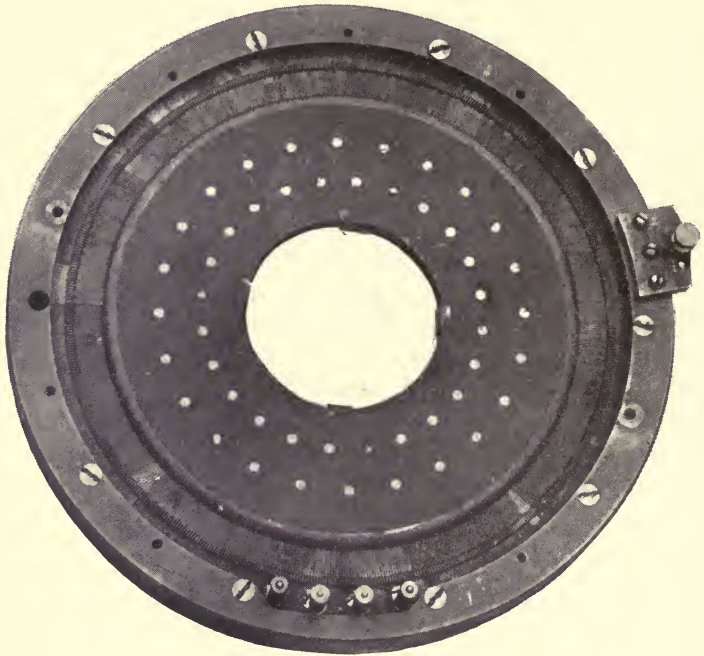

FIG. 141.

H.F. Alternator Armature ; a fixed disc of Mordey Type.

quently made statement that a high frequency alternator of any considerable output is an impossibility.

No less an authority than Professor J. A. Fleming has considered an alternator of sufficiently high output and frequency for wireless communication a practical impossibility.

This alternator is a small machine of the Mordey type,

having a fixed armature in the form of a thin disc, or ring, and a revolving field magnet with 360 teeth, or polar projections. At a speed of 139 revolutions per second, an alternating current of 50,000 cycles per second and a terminal E.M.F. of 65 volts is generated. The maximum



FIG. 142.

Field Magnet Disc of H.F. Alternator.

output of the alternator at the above frequency is 0.3 kilowatt.

Very little difficulty seems to have obtained in running the machine at so high a speed, a simple flat belt drive being used, and a thin self-centring shaft entirely obviates excessive vibration and pressure on the bearings.

Although, as above stated, the maximum output of the

alternator is 0.3 kilowatt, measurement with hot wire instruments shows that, when connected in the transmitting circuit, only about 36 watts is used. Of this energy, one-third, or 12 watts, is radiated as electrical waves from the antenna, the remainder, or 24 watts, is dissipated as heat in the ohmic resistances of the transmitter button, tuning inductance, and transformer secondary.

Owing to resonance, the E.M.F. of the antenna is much higher than the terminal voltage of the alternator. A measurement with electrostatic voltmeter indicates that the potential is approximately 2,000 volts.

The transmitter button is located at a potential node, and, when speaking, the potential fall across its terminals is between 5 and 15 volts. The current flow, indicated by a hot-wire ammeter, is about 2.1 amperes.

While transmitting speech wirelessly, the action of the system is briefly as follows :—With the alternator running, a steady alternating current, at a frequency of 50,000 periods per second, flows through the radiating circuit. A resistance change in the transmitter button varies this current, and, in proportion to this variation, the R.M.S. potential of the antenna rises and falls. As the radiation varies directly as the potential, the radiated waves also vary in intensity in direct proportion to the resistance changes in the transmitter button.

RECEIVING APPARATUS AND CIRCUITS.

In this test the receiving station was located on the water front at Plymouth. A sectional wooden mast, 170 feet high, carried a vertical fan of wires, branching at the top in a manner similar to the transmitting station. The receiving circuits differ in no wise from those employed in wireless telegraphy. The receiving antenna is grounded through a tuning inductance, and the primary of a transformer, in whose secondary circuit the detector was placed.

TEST OF WIRELESS SPEECH TRANSMISSION.

After inspection of the transmitting station at Brant Rock, Mr Keating and myself went to the Plymouth station, arriving there about 3.30 P.M. After a slight

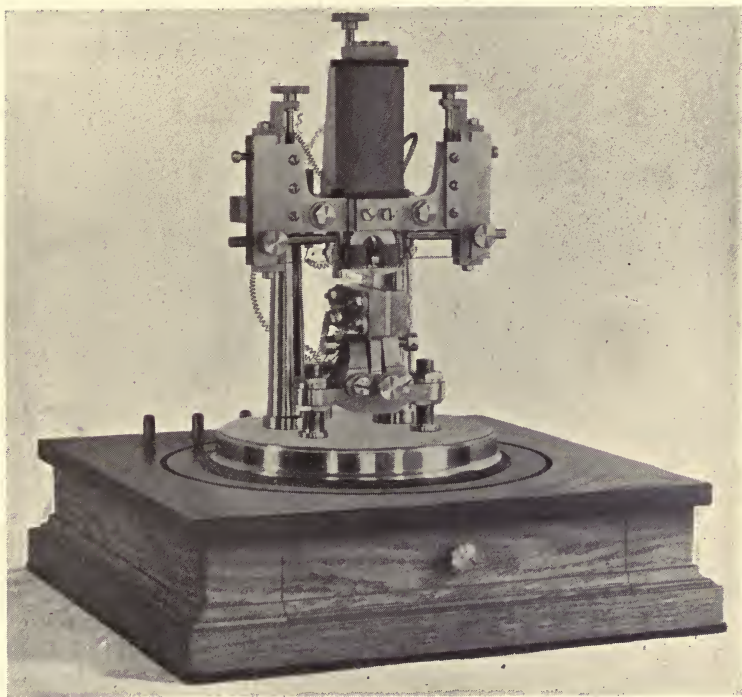

FIG. 143.

Receiving Relay Amplifying Fifteen Times.

delay the alternator at Brant Rock was started, and a phonograph selection—a violin solo—was transmitted. This was by repeater, the phonograph talking into a transmitter, and from thence over a short line to the windings of a "Differential Relay," one of whose buttons

was included in the radiating circuit. At Plymouth this could be heard fairly well at times, the characteristic timbre of the violin coming out about as well as the imperfections of the phonograph record would permit. Apparently much difficulty was experienced with the repeater button packing, for the variations in received volume were enormous. During this selection, some one at Brant Rock would occasionally tap or jar the repeater button, producing thereby a loud sound in the Plymouth receivers, and for a few seconds thereafter greatly improving the transmission.

After another phonograph selection, Mr Davis, at Brant

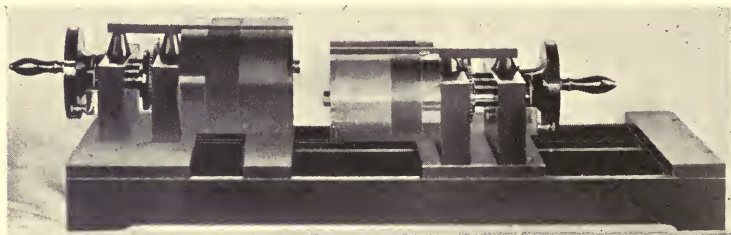

FIG. 144.

Receiving Transformer in which Primary and Secondary, and also their Distance Apart, *i.e.*, Coupling, may be varied for Tuning Purposes.

Rock, talking through the repeater, sent a short message to Mr Keating at Plymouth, which was correctly received, barring an error in a single word. While a distinct improvement over the phonograph, a large variation in received intensity still existed. The repeater was then discarded, and Professor Fessenden talked some ten minutes to me, using a directly connected transmitter. Although still variable in volume, the quality of this transmission was most excellent, and I had not the slightest difficulty in following everything he said. It was even possible to distinguish fairly well between single consonant letters, such as "B" and "P." A high-pitched

whistle, certainly over 5,000 periods per second, came through clearly, and even loudly.

Taken as a whole, I should consider the speech transmission as distinctly commercial.

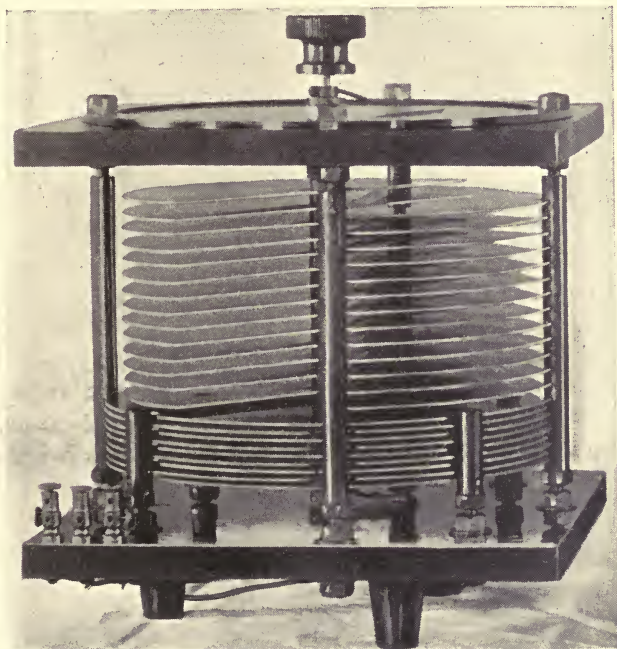

FIG. 145.

Variable Condenser for Tuning Purposes.

DETAIL OF ACCESSORY APPARATUS EMPLOYED.

The buttons employed in both the repeater and the direct transmitter were similar to those of our radiophone transmitter, heavy platinum-iridium faced electrodes, and a granular carbon filling, 40-60, being used.

The repeater, or "Differential Relay," is a somewhat

novel form. While at Brant Rock several tests of this repeater were made, such as talking into it over a "zero" line, with a loud-speaking receiver directly connected to the other side. Watch ticks, phonograph selections, and the voice were amplified apparently several times, but the conditions of these tests were not such as to show whether or no the device was in any way sensitive to the feeble incoming transmission. Unfortunately, but one repeater was available, so that no tests could be made with it at the receiving end.

POSSIBILITIES OF PRESENT SYSTEM AND APPARATUS.

Professor Fessenden told me that the apparatus employed was not, at the time of the test, operating at anywhere near its maximum efficiency.

The alternator, although operating at 50,000 cycles, was designed for 100,000. At this frequency, the radiation from the antenna, other factors remaining the same, is greatly increased. As the radiation increases with the fourth power of the frequency, this doubling of the periodicity would increase the radiation sixteen-fold, and, as the range varies with the square root of the radiation intensity, the distance of communication would be increased four times. This would mean about forty miles with the present equipment.

Equally, improvement in transmitter operation would give a decided gain. It was stated by Professor Fessenden, and seemed probable to me, that the present transmitter only varied about 5 per cent. of the total radiated energy. With another form of transmitter, not used in any of the tests, a variation of 50 per cent. is claimed. This improved form is merely a condenser telephone transmitter placed in shunt to the radiating circuit, the small capacity variations resulting from the vibration of one of the plates throwing the radiating circuit in and out of tune with the alternator. In theory, at least, this form of transmitter should give the

results claimed. If it did in practice, it would mean an increase in the energy telephonically modulated of ten times, and an increased range of three times.

Probably, with the apparatus I saw in operation worked to its maximum efficiency, a range of about 100 miles might be reached, preserving commercial transmission.

POSSIBLE DEVELOPMENTS OF THE SYSTEM.

It is difficult, with our present knowledge of high frequency alternators and other mechanical sources of steady high frequency current, to assign a definite limit to the amount of energy that can be generated and radiated. Probably several kilowatts can be generated by mechanical sources of high frequency current, sources resulting from a simple development of the present devices. How much of this energy can be effectively telephonically modulated is a still more difficult question. Where a direct action upon the high frequency current is concerned, it seems that 100 watts was an upper limit of the microphonic type of transmitter. This amount of energy, in the form of telephonically modulated electrical waves, would probably give commercial transmission over several hundred miles, under favourable conditions. The electrostatic transmitter, which depends upon an indirect action upon the energy, may be capable of varying several kilowatts, and so increasing the range to a thousand miles or more. This, however, is mere speculation.

It is my opinion that ranges of several hundred miles are now possible, but a considerable amount of development work will be required before these are attained.

The question of range, although important, seems to me subordinate to the question of

SIMULTANEOUS WORKING OF SEVERAL STATIONS.

As stated under the possibilities of the present system and apparatus, the receiving station was not sharply tuned.

Yet, even with the circuits employed, I found by experiment that a variation of 5 per cent. in the tune of the receiving circuit reduced the volume of receiving by some 90 per cent. Assuming that the present range of frequency available and economical from mechanical sources is from 50,000 to 150,000 cycles per second, something less than ten stations could exist harmoniously in a given district. The number would of course depend upon the permissible cross-talk, and this, in turn, would depend upon the distances between stations as well as the differences in frequency. Save in a specific case, with these distances known, it would be impossible to define, even approximately, the number of simultaneous conversations that might wirelessly exist.

It would seem that there were three distinct sources of high frequency current available for wireless telephony. The first of these is the alternator already described. The second is the "singing arc," which, according to Fessenden, is capable of development into a fairly steady and definite frequency source. The third source is a "condenser dynamo" which is simply a rapidly variable condenser, formed of radially slotted discs, revolving in opposite directions in such manner as to vary the capacity from disc to disc some hundred thousand or more times a second. Connected with a source of direct current, this rapid variation in capacity creates a high frequency current. According to Fessenden's calculations, a very compact machine, delivering about two kilowatts of high frequency current, and of extreme constructional simplicity, can be made in this manner. No machine of this type was shown, and it did not appear that it had been tested on any practical scale. From theory, however, the service should be operative in the manner claimed, and form a simple and cheap source of high frequency current.

BOSTON, 24th *December* 1906.



ADDENDA AND CORRIGENDA

To page

- xiii.—Chap. XVII. should be entitled “The Impure Duddell Phenomenon.”
- 99, *Note*.—For “Weselius,” read “Wesselius.”
- 101, *Note*.—For “Reinart,” read “Reinartz.”
- 103, *Note*.—For “4. I. 07,” read “16. I. 07.”
- 126, *Note*.—The damping factor, $\epsilon^{-\frac{R_0 t}{L}}$, should read $\epsilon^{-\frac{R_0}{2L}t}$.
- 142.—Chap. XIII. describes, *inter alia*, the Pure Duddell Phenomenon.
- 145, *Note*.—See also P. Bary, *Eclair. Electr.*, li., p. 45, 1907.
- 154, *Note*.—See also lecture by Poulsen on “System for Producing Continuous Electric Oscillations,” *Transactions of the International Electric Congress at St Louis* (1903), ii., p. 963, 1904-05.
- 155, *Note*.—On the influence of gases and of cooling of the electrodes, see Simon and Malcolm, *Phys. Zeitschr.*, viii., p. 471, 1907, and *Jahrbuch d. drahtlose Telegr. u. Teleph.*, i., p. 33, 1907.
- 161.—*Fig.* 120A should be entitled “Adjustable Battery of Arcs of the Gesellschaft für drahtlose Telegraphie” (Berlin)—not Ruhmer’s.
- 164, *Figs.* 122A and 122B.—Ruhmer’s high-tension arc H.F. current generator differs from others in that the length of the arc is maintained constant by an ingenious but simple arrangement of the electrodes. These are in the form of wires which are moved with a slow and constant velocity, so that the arc is formed between points on the sides of the wires, fresh portions of which are constantly being brought forward to where the arc burns, thus keeping the arc-length constant, and providing a cooler electrode than can be otherwise attained (see Appendix, p. 200).
- 166, *Note*.—See also Fleming, lecture at the Royal Institution, London, 24th May 1907; and Tissot, Report to l’Assoc. française pour l’Avancement des Sciences, August 1907.
- 173, *Note*.—See also Austin, *The Electrician*, p. 794, 1907, on a thermo-electric detector.
- 174.—Chap. XVII. should properly be entitled “The Impure Duddell Phenomenon.” The pure Duddell phenomenon is treated of in Chap. XIII.
- 185, see also E. Ruhmer, German patent, application R. 23,796, Class 21a, of 31st December 1906, published 22nd July 1907.
- 215.—Zacharias u. Heinicke, “Practisches Handbuch der drahtlosen Telegraphie u. Telephonie,” Wien u. Leipzig, 1907. Partheil, “Die drahtlose Telegraphie u. Telephonie,” 2 Aufl., Berlin, 1907. Stockhausen, “Der eingeschlossene Lichtbogen bei Gleichstrom,” Leipzig, 1907. Zenneck, “Electromagnetische Schwingungen und Drahtlose Telegraphie,” Stuttgart, 1905.

BIBLIOGRAPHY.

- BELL, ALEXANDER GRAHAM. Das Photophon. Leipzig, 1886.
- BIEGON VON CZUDNOCHOWSKI, W. Das elektrische Bogenlichts. Leipzig, 1906.
- BIRRENBACH, H. Theorie und Anwendung des elektrischen Bogenlichts. Hannover, 1903.
- HEINKE, C. Handbuch der Elektrotechnik. Leipzig, 1904.
- JENTSCH, OTTO. Telegraphie und Telephonie ohne Draht. Berlin, 1904.
- MAZZOTTO, D. Telegraphie und Telephonie ohne Draht. München, 1906.
- MONASCH, B. Der elektrische Lichtbogen. Berlin, 1904.
- NERZ, F. Scheinwerfer und Fernbeleuchtung. Stuttgart, 1888.
- PRASCH, A. Die Telegraphie ohne Draht. Wien, 1902.
- PRASCH, A. Die Fortschritte auf dem Gebiete der drahtlosen Telegraphie. Stuttgart, 1905-6.
- Radiophone, The. St Louis, 1904.
- RIGHI, A., und DESSAU, B. Die Telegraphie ohne Draht. Braunschweig, 1903 und 1907.
- RUHMER, E. Das Selen und seine Bedeutung für die Elektrotechnik. Berlin, 1902.
- TESLA, N. Untersuchungen über Mehrphasenströme und über Wechselströme höher Spannung und Frequenz. Halle, 1895.
- Americ. Teleph. Jour.—American Telephone Journal (New York).
- Ann. d'Elektrotechn.—Annalen der Elektrotechnik (Leipzig).
- Ann. d. Phys.—Annalen der Physik (Leipzig).
- Arch. d'Électr. Med.—Archives d'Électricité médicale (Bordeaux).
- Beiblätter—Beiblätter zu den Annalen der Physik (Leipzig).

- Berichte der Erlanger physikalisch - medizinischen Sozietät
(Erlangen).
- Bulletin de la Societe française de Physique (Paris).
- Comptes Rendus—Comptes Rendus Hebdomadaires des Seances
de l'Academie des Sciences (Paris).
- D.R.P.—Deutsches Reichspatent.
- Éclair. Électr.—L'Éclairage Électrique (Paris).
- Electrical Engineer (New York).
- Electrical Review (London).
- Electrical Review (New York).
- Electrical World and Engineer (New York).
- Electrician (London).
- Électricien (Paris).
- Elektrotechniker (Wien).
- Elettricista (Rome).
- Engineering (London).
- English Mechanic (London).
- E.T.Z.—Elektrotechnische Zeitschrift (Berlin).
- Für alle Welt (Berlin).
- Jahrbuch der Schiffbautechnischen Gesellschaft (Berlin).
- Journ. de Phys.—Journal de Physique Theorique et Appliquée
(Paris).
- Journal der russ. phys. Chem. Gesellschaft.
- Journal of the Proceedings of the Institution of Electrical
Engineers (London).
- Journal of the Society of Telegraph Engineers.
- Mechaniker (Berlin).
- Nature (London).
- Nuovo Cimento (Pisa).
- Phil. Mag.—The London, Edinburgh, and Dublin Philosophical
Magazine and Journal of Science (London).
- Phil. Trans.—Philosophical Transactions of the Royal Society of
London.
- Phys. Zeitschr.—Physikalische Zeitschrift (Leipzig).
- Pogg. Ann.—Poggendorff, Annalen der Physik (Leipzig).
- Proceedings of the American Institution of Electrical Engineers.
- Proceedings of the Physical Society of London.
- Proceedings of the Royal Society (London).
- Rev. ind.—Revue industrielle (Paris).

- Rendiconti dei Lincei—Rendiconti della Reale Accademia dei Lincei (Rome).
- Scientific American (New York).
- Tijdschrift v. Geneeskunde.
- Technische Rundschau (Berlin).
- Western Electrician (Chicago).
- Wied. Ann.—Wiedemann's Annalen der Physik und Chemie (Leipzig).
- Zeitschr. f. d. phy. u. chem. Unterricht—Zeitschrift für den physikalischen und chemischen Unterricht (Berlin).
- Zeitschrift für Elektrotechnik und Maschinenbau (Wien).
- Zeitschr. f. Schwachstromtechn.—Zeitschrift für Schwachstromtechnik (München).

NAME INDEX.

- ABRAHAM, H., 110, 184
 Armstrong, 83
 Ascoli, 128, 143
 Ayrton, H., 145, 146, 155
 Ayrton, W. E., 197
- Bell, A. G., 8, 10-14, 19, 30, 31
 Benischke, G., 192
 Blondel, A., 110, 119, 129, 145, 177,
 182, 184
 Braun, F., 27, 99, 124, 127
 Brown, 102
 Brown, S. G., 166
- Campos, 153, 159, 170
 Cassuto, L., 155
 Chladni, 39
 Clark, L., 3
 Collins, A. F., 83, 94, 95
 Corbino, 143, 178
 Cram, E. R., 31
- De Forest, L., 173
 De la Rive, 183
 Dolbear, A. E., 93
 Dolezalek, F., 134
 Ducretet, 82
 Duddell, W., 25, 99, 134, 142, 145,
 147, 150, 160, 175, 178, 182, 184,
 187, 191
 Dussaud, 78
- Ebert, 77
 Edison, Th. A., 94, 196
 Eisenstein, S., 117, 119, 121, 124, 151,
 158
 Engisch, 83
 Evans, C. J., 89
 Ewing, 133
- Fabry, 144
 Faraday, 9
 Feddersen, 130
 Fessenden, R. A., 103, 128, 130, 135,
 138, 140, 153, 158, 170, 173, 180,
 181, 196
 Fitzgerald, G. F., 184
 Fleming, J. A., 173
 Franz, R., 101
 Frith, 187
- Gavey, 89, 91
 Gesellschaft für Drahtlose Telegraphie
 (Berlin), 116, 161, 163, 170, 174
 Giltay, J. W., 14, 16, 20, 22
 Grandquist, G., 144, 155
 Gray, E., 2
- Härden, J., 110
 Hähnemann, W., 159, 174, 189
 Hayes, H. V., 30, 31
 Heinke, C., 131, 143
 Hertz, H., 77, 130
 Hewitt, C., 116, 179
 Hornemann, 172
 Hutchison, M. R., 89
- Jamieson, A., 14
 Janet, 143
- Kaufmann, 145
 Kerr, 9
 König, 14
 Koepsel, 152
 Krelle, O., 62
- Leblanc, M., 134
 Lecher, 142
 Levy, 27
 Lodge, 132
 Lonardi, 102, 107

- M'Carty, F. J., 99
 Maiche, L., 82
 Majorana, Q., 107, 113, 118
 Maisel, S., 145, 178
 Manzetti, 143, 178
 Marconi, G., 96, 99
 May, 3
 Mazzotto, D., 159
 Mercadier, 11
 Monasch, B., 155, 161
 Mosler, H., 85, 87, 99, 118, 150, 159,
 185
 Munday, A. J., 2
 Musits, R., 83
- Neilson, 102
 Nerz, F., 62
 Nussbaumer, O., 99, 118, 150
- Örling, 83
- Perry, 76
 Penkert, W., 142
 Pierce, W., 116
 Plisner, 92
 Poulsen, V., 154, 155, 156, 158, 160,
 163, 174, 181, 191, 192
 Preece, W. H., 89, 91
- Rautenkrantz, J., 131
 Reich, M., 32, 116, 124, 137, 138, 140,
 145, 179
 Reinartz, J., 101
 Reithoffer, M., 189
 Righi, A., 154, 181
 Rodgers, 187
 Ruedenberg, R., 135
- Ruhmer, E., 2, 16, 19, 23, 25, 29, 32,
 33, 36, 43, 72, 76, 83, 112, 134,
 160, 167, 178, 184, 190, 192
 Ruppin, W., 101
- Salomons, D., 133
 Schmidt, K. E. F., 133
 Schuckert, 49
 Sella, 77, 78
 Short, 1
 Siemens, W., 4
 Simon, H., Th., 20, 23, 25, 26, 32, 33,
 34, 99, 116, 124, 125, 137, 138,
 145, 148, 150, 154, 173, 179, 181,
 191
 Smith, W., 2
 Stark, J., 155
 Steinmetz, C. P., 132
 Szczepanik, J., 103
- Tainter, S., 4, 6, 8
 Tesla, N., 131, 132, 196
 Thomson, E., 113, 132, 142, 179, 180
 Thomson, W. (Kelvin), 114, 178
 Thury, 134
 Tissot, 143, 173
- Valbreuze, 178
 Valle, 92
 Vogel, H. C., 58
 Vossnack, E., 135
 Vreeland, K., 194
- Wehnelt, 190
 Weintraub, 178
 Wertheim-Salomonsen, 143
 Weselius, H., 99
 Wiedemann, 77
 Wien, M., 127, 133, 135
 Wilson, E., 89
- Zickler, K., 77, 103

SUBJECT INDEX.

- A**BSORPTION of heat rays in air, 71
of light of different wave-lengths in air, 71, 73, 78
Acetylene flame transmitter, 16
signal lamp, 49
Acoustic control of arc, 23, 84
Active arc, 192
length of arc, 156
Advantages of light-telephony, 74
Air blast, 113, 180, 183, 185, 192
spark gap, 124, 179, 181
Aluminium electrodes, 113, 163
Alternate current curve form, 111, 119, 130
current, rectangular curve, 119
current siren, 133
current transformer, 114, 138
Alternator, 137, 138, 206
Aperiodic discharge, 127
Arc characteristic, 145-148, 191
discharge, 99, 110, 111, 190
generator, 154, 159, 168, 185, 190, 193, 199
hysteresis, 147
interruption, 185, 191
interruptor, 185, 189, 191
-lamp concert, 26
length, influence of, 64, 166
as microphone, 29
as telephonic receiver, 23
pianoforte, 144
speaking. *See* Speaking Arc.
voltage, influence of, 64
Articulation in wave telephony, 170
Audibility in electric wave telephony, 168
in light-telephony, 55, 67, 68
in radiophony, 170
Audion, 173
- B**ALANCING cells, 23
Berliner's granular microphone, 27
Best conditions of speaking arc for radiophony, 29, 38, 60
size and resistance of selenium cell for light-telephony, 69
Blast-magnet, 170, 180, 183, 184, 187, 189, 192
Bolometer, 76
Braun's circuit, 99, 127, 135
tube, 181, 189
- C**APSULE, manometric, 14, 16, 17
Carbonic acid gas, 113
Cathode ray oscillograph, 168
Characteristic of the arc, 146, 148
of the arc-interruptor, 191
of the musical arc, 191
of the Poulsen generator, 191
Characteristics of selenium cells, 70
Choking coil, 23, 110, 143, 156, 182
Cinematograph, 36
Cinematographic records, 112, 115, 185
Closed circuit wireless telephony, 2, 79-87
Colour-sensitive selenium cells, 73
Complete station for light telephony, 53
Condenser dynamo, 135
Conductivity of spark gap, 125, 129
Construction of selenium cells, 41
Control by microphone current, 96, 170
of the aerial wire current, 129
of the field of a D.C. dynamo, 99, 136, 170
of the oscillating circuit, 129, 184
of the supply current, 99, 129, 151, 184

Cooling of electrodes, 155, 163, 174,
181, 192
Copper electrodes, 155, 160, 163
Cored carbons, 27, 187
Coupling, 23, 138, 173, 194
Critical current, 156, 160
Current curve, 190

DAMPED oscillations, 130
Damping, 105, 127, 180
Dark rays, 76
Deckert's microphone, 90
Demonstration apparatus for light-tele-
phony, 18, 21, 54
Direct current, high tension, supply to
spark gap, 124, 128
Disruptive discharge, 177, 179, 180,
182
Discharge voltage, 110, 127, 129
Discharges in series, 119, 127, 128
Disadvantages of light-telephony, 75
of wave telephony, 195
Divergence of searchlight beam, 63
Divided arc, 160
Duddell phenomenon, 128, 142, 145,
148, 174, 182, 187, 191
Duration of charging, 126
Dynamic characteristic of the arc, 146,
191
Dynamo machine, 26

ELECTRIC coupling, 23
motor boat, 45
Electrodynamical theory of discharge in
gases, 147
Electrolytic cells, 97, 168, 172
Electromagnetic induction, 89
Electromotograph telephone, 94
Electrostatic induction, 92
Energy in oscillating circuit, 174
Exhibition, Chicago, 10, 11
of electrical novelties (Berlin), 42,
185
of electrical novelties at Madison
Square
motor-boat (Wannsee), 43
St Louis, 31, 67, 89
Extinction of arc, 188, 191

FIELD magnet control, 26, 99, 137
Film, 36, 38
Filtration of heat rays, 71
Flame arc carbons, 27, 73

Fluorescent bodies, 78
screen, 190
Fog, 68, 76
Forced vibrations, 183, 185, 188, 192
Foucault currents, 130
Frequency variations of electric waves,
104, 132, 140
Future of electric wave telephony, 194,
196
of light-telephony, 74

GASOLENE vapour, 15
Geissler tube, 181
Gimbals, searchlight on, 67
Glass parabolic mirror, 53
Gouraudphone, 1
Granular carbon microphone, 27

HAMMER break, 20
Hard selenium cells, 71
Heat conductivity of electrodes, 148,
155, 156
Hertz's phenomenon, 77
Heterodyne receiver, 173, 201
High frequency alternator, 131, 138,
174, 202, 206, 212
High tension arc, 128, 163, 167, 178
Hydrogen atmosphere, 154, 166, 192
Hysteresis curve, 147, 148, 177, 191

IMPORTANCE of electric wave
telephony, 194, 196
of light-telephony, 75
Impregnated carbons, 27
Impure Duddell phenomenon, 177, 178,
180, 182
Inactivity of arc, 150, 170, 192
of spark, 101, 113, 124
Induction telephony, 2, 88-95
Inductive coupling, 23
Influence of the supply voltage on
selenium cells, 70
of the transparency of the air, 67
Intensity variations of electric waves,
102, 129, 137, 140
Intermittent partial discharges, 176
Interruption phenomena, 191
Interruptor characteristic, 191
Invisible rays, 76

JOULEAN heat, 26

KITES, 93**L**AWS of radiation, 28

Length of arc for Duddell phenomenon, 145
of arc in impure Duddell phenomenon, 176

Light filter, 73, 76

Light-electric telegraphy, 77, 103

Light-telephony, 2, 14-19, 20-78

Limitation of supply current by choking coil, 111

Logarithmic decrement, 127

Loose coupling, 173

Loudness of the speaking arc, 22, 26

MAGNETIC blast, 113, 183, 185, 192, 193

detector, 97, 107, 129

Magnetically influenced arc, 89, 156, 163, 170, 183-195

Manometric capsule, 14, 15, 22, 170
flame, 129

Map of Wannsee experiments, 48

Marconi transmitter, 96

Maxwell's theory, 88

Mercury arc, 115, 124, 179, 194

arc as interruptor, 115

vapour wave detector, 173

Metal electrodes, 159, 174

Microphone, 1, 12, 22, 23, 25, 27, 30, 83, 89, 93

contact, 99

large current, 83

Mirror, focal length of, 64

Motor boat exhibition, 43

Mounting of selenium cells, 41

Multi-phase current, 119

Multiple arc generator, 160

spark discharge, 112

Multiplex light-telephony, 73
telephony, 194

Musical arc, 142, 175, 180, 184, 187, 191

NICOL'S prism, 9

Non-arcing metals, 113

OPACITY of crystalline selenium, 70

Oscillating circuit, 99

Oscillation trains, 106, 116

Oscillations of an arc in a magnetic field, 188, 190

Oscillatory discharge, 105, 135, 183

Oscillograph, cathode ray, 167

Oscillographic methods, 190

records, 144, 148, 175, 176, 188

Outfit for wave telephony, 170

Oxide coherer, 172

PARABOLIC mirror, 1, 5, 18, 30, 41, 49, 58

Partial discharges, 114, 115, 118, 128

Photographophone, 36, 40

Photophone, 4, 6, 9, 14

Photophonic receiver, 30, 32

sender, 6, 10, 30

Photophonogram, 37

Porcelain core for selenium cell, 41

Portable light telephonic apparatus, 57
power station, 57

Poulsen generator, 154-158, 174, 181, 190

Practical uses of induction telephony, 95

uses of wave telephony, 196

Priority of invention of speaking arc, 31

RADIOPHONE, 10

Radiophony, 2, 3-78

Radiotelegraphic conference, 166

Range of hydrotelephony, 80, 83

of induction telephony, 90

of light-electric telephony, 78

of light-telephony, 75

Rates of sparking, 111, 115, 125

Receiving station, radiophonic, 8, 9

tube for light-telephony, 77

Resistance of selenium cells, 5

Resonance, 137, 185, 187

Rotating mirror, 168

SEARCHLIGHT, 31, 43, 49, 75

Secret conversation, light-telephonic, 74

Selenium, 3

cells, 4, 15, 21, 30, 32, 38, 68, 73

cell, speed of action, 70

Self-decohering coherers, 97

Sensibility of selenium cells, 41, 42

Series arrangement of arc, 160

Single impulses, 180

-phase current, 111

Singing spark, 97, 102

Smoke, 77

- Soot cells, 11
 Sound propagation through air, 2
 propagation through water, 2
 Spark coil, 96, 99, 102, 104, 109, 114, 151
 telephony, 96-130
 Speaking arc, 23, 26
 arc as photophonic transmitter, 28, 29
 spark, 97, 102
 trumpet, 1
 Stage arc lamp, 49, 53
 Star connection, 120
 Static arc characteristic, 146
 Striking voltage, 176
 Submarine signals, 2
 Sun's rays, 6
 Superposition of microphone current on supply current, 60
 Supply current for speaking arc in light-telephony, 64
 voltage for selenium cells, 69
- T**ELEGRAPHONIC receiver, 173
 Telegraphy, light-electric, 74
 Telephone, loud-speaking, 1
 Telephony by electric forces, 77-214
 by heat rays, 3-78
 by light rays, 3-78
 by ultra-violet rays, 77
 Tesla transformer, 166
 Theory of arc hysteresis, 147
 of Poulsen generator, 154, 181, 190, 191, 199
 of the speaking arc, 26
 Thermophone, 10
 Thermophonic receiver, 11, 12
- Thomson arrangement, 179, 180, 187
 Thomson's formula, 114, 127, 178
 Three-cornered circuit, 121, 123
 -phase current, 119
 -phase spark gaps, 121, 123
 Time of arc striking, 126, 176
 Torpedo-boat searchlight, 43
 Trains of damped waves, 179-182
 Transformer, 23, 26, 111, 114
 Transmitter photophonic, 4, 6, 9, 10
 for wave telegraphy, 96
 Transparency of air, 55, 67
 of ebonite, 76
 Turbine interruptor, 104
- U**LTRA-VIOLET rays, 77
 Undamped oscillations, 130
 Undulating light rays, 30
 Unsymmetrical spark gap, 181
 Uses of electric-wave telephony, 194, 196
 of light-telephony, 57
- V**ACUUM tubes, 167
 Valve spark gap, 181
 Variation of coupling, 138, 194
 of transmitter frequency, 140
 Visibility of searchlight beam, 75
- W**ANNSEE experiments, 43
 Wave telephony, 2, 96-195
- Z**INC electrodes, 113



LIST OF WORKS
ON
ELECTRICAL SCIENCE

PUBLISHED AND FOR SALE BY

D. VAN NOSTRAND COMPANY,
23 Murray and 27 Warren Streets, New York.

- ABBOTT, A. V. *The Electrical Transmission of Energy. A Manual for the Design of Electrical Circuits. New Edition, revised and rewritten. With many Diagrams and Engravings and Folding Plates. 8vo, cloth. Net, \$5.00.*
- ANDERSON, GEO. L., A.M. (Capt. U.S.A.). *Handbook for the Use of Electricians in the operation and care of Electrical Machinery and Apparatus of the United States Seacoast Defenses. Prepared under the direction of Lieut.-General Commanding the Army. Illustrated. 8vo, cloth. \$3.00.*
- ARNOLD, E. *Armature Windings of Direct-Current Dynamos. Extension and Application of a general Winding Rule. Translated from the original German by Francis B. DeGress, M.E. Illustrated. 8vo, cloth. \$2.00.*
- ASHE, S. W., and KEILEY, J. D. *Electric Railways, Theoretically and Practically Treated—Rolling Stock—With Diagrams and Folding Plates. 12mo, cloth, 290 pp. Illustrated. Net, \$2.50.*
- ATKINSON, A. A., Prof. (Ohio Univ.). *Electrical and Magnetic Calculations. For the use of Electrical Engineers and others interested in the Theory and Application of Electricity and Magnetism. Second Edition, revised. Illustrated. 8vo, cloth. Net, \$1.50.*
- ATKINSON, PHILIP. *The Elements of Dynamic Electricity and Magnetism. Fourth Edition. Illustrated. 8vo, cloth. \$2.00.*
Elements of Electric Lighting, including Electric Generation, Measurement, Storage, and Distribution. Tenth Edition, fully revised and new matter added. Illustrated. 8vo, cloth. \$1.50.
Power Transmitted by Electricity and Applied by the Electric Motor, including Electric Railway Construction. Illustrated. Fourth Edition, fully revised and new matter added. 8vo, cloth. \$2.00.
- AYRTON, HERTHA. *The Electric Arc. 8vo, cloth. Illustrated. 479 pp. Net, \$5.00.*

- BIGGS, C. H. W.** First Principles of Electricity and Magnetism. Illustrated. 12mo, cloth. \$2.00.
- BLAKESLEY, T. H.** Papers on Alternating Currents of Electricity. For the use of Students and Engineers. Third Edition, enlarged. 12mo, cloth. \$1.50.
- BOTTONE, S. R.** Electric Bells and All about Them. 12mo, cloth. 50 cents.
 Electrical Instrument-Making for Amateurs. A Practical Handbook. Enlarged by a chapter on "The Telephone." Sixth Edition. With 48 Illustrations. 12mo, cloth. 50 cents.
 Electric Motors, How Made and How Used. 12mo, cloth. 75 cents.
- BOWKER, WM. R.** Dynamo, Motor, and Switchboard Circuits for Electrical Engineers: a practical book dealing with the subject of Direct, Alternating, and Polyphase Currents. With over 100 Diagrams and Engravings. 8vo, cloth. Illustrated. Net, \$2.25.
- CHILD, CHAS. T.** The How and Why of Electricity: a book of information for non-technical readers, treating of the properties of Electricity, and how it is generated, handled, controlled, measured, and set to work. Also explaining the operation of Electrical Apparatus. 8vo, cloth. Illustrated. \$1.00.
- COOPER, W. R.** Primary Batteries: their Theory, Construction, and Use. 8vo, cloth, 324 pp. 131 Illustrations. Net, \$4.00.
- CROCKER, F. B., and WHEELER, S. S.** The Practical Management of Dynamos and Motors. Revised and enlarged. Illustrated. Sixteenth Thousand. 12mo, cloth. \$1.00.
- CROCKER, F. B.** Electric Lighting. A Practical Exposition of the Art for the use of Electricians, Students, and others interested in the Installation or Operation of Electric-Lighting Plants. Volume I.: The Generating Plant. Sixth Edition, entirely revised. 8vo, cloth. \$3.00. Volume II.: Distributing System and Lamps. Fourth Edition. 8vo, cloth. Each, \$3.00.
- DESMOND, CHAS.** Electricity for Engineers. Part I.: Constant Current. Part II.: Alternate Current. Revised Edition. Illustrated: 12mo, cloth. \$2.50.
- DIBDIN, W. J.** Public Lighting by Gas and Electricity. With many Tables, Figures, and Diagrams. 8vo, cloth. Illustrated. 537 pp. \$8.50.
- DYNAMIC ELECTRICITY;** Its Modern Use and Measurement, chiefly in its application to Electric Lighting and Telegraphy, including: 1. Some Points in Electric Lighting, by Dr. John Hopkinson. 2. On the Treatment of Electricity for Commercial Purposes, by J. N. Shoolbred. 3. Electric-Light Arithmetic, by R. E. Day, M.E. 18mo, boards. (No. 71 Van Nostrand's Science Series.) 50 cents.
- EWING, J. A.** Magnetic Induction in Iron and other Metals. Third Edition, revised. Illustrated. 8vo, cloth. \$4.00.
- FISHER, H. K. C., and DARBY, W. C.** Students Guide to Submarine Cable Testing. Third Edition, new, enlarged. 8vo, cloth. Illustrated. Net, \$3.50.
- FISHER, W. C.** The Potentiometer and Its Adjuncts. 8vo, cloth. Net, \$2.25.

- FISKE, BRADLEY A., Lieut., U.S.N. *Electricity in Theory and Practice; or, The Elements of Electrical Engineering.* Tenth Edition. 8vo, cloth. \$2.50.
- FLEMING, J. A., Prof. *The Alternate-Current Transformer in Theory and Practice.* Vol. I.: The Induction of Electric Currents. 500 pp. Fifth Issue. Illustrated. 8vo, cloth. \$5.00. Vol. II.: The Utilization of Induced Currents. Third Issue. 594 pp. Illustrated. 8vo, cloth. \$5.00.
Electric Lamps and Electric Lighting. 8vo, cloth. \$2.50.
- FOSTER, H. A. *Electrical Engineers' Pocket Book.* With the Collaboration of Eminent Specialists. A handbook of useful data for Electricians and Electrical Engineers. With innumerable Tables, Diagrams, and Figures. The most complete book of its kind ever published, treating of the latest and best Practice in Electrical Engineering. Third Edition, revised. Pocket size, full leather, 1000 pp. \$5.00.
- GORE, GEORGE, Dr. *The Art of Electrolytic Separation of Metals (Theoretical and Practical).* Illustrated. 8vo, cloth. \$3.50.
- GRAY, J. *Electrical Influence Machines: Their Historical Development and Modern Forms.* With Instructions for making them. Second Edition, revised and enlarged. With 105 Figures and Diagrams. 12mo, cloth. Illustrated. \$2.00.
- GUILLEMIN, AMEDEE. *Electricity and Magnetism.* Translated, revised, and edited by Prof. Silvanus P. Thompson. 600 Illustrations and several Plates. Large 8vo, cloth. \$8.00.
- GUY, ARTHUR F. *Electric Light and Power.* Giving the result of practical experience in Central-Station Work. 8vo, cloth. Illustrated. \$2.50.
- HAMMER, W. J. *Radium, and Other Radio-active Substances; Polonium, Actinium, and Thorium.* With a consideration of Phosphorescent and Fluorescent Substances, the properties and applications of Selenium, and the treatment of disease by the Ultra-Violet Light. With Engravings and Plates. 8vo, cloth. Illustrated. \$1.00.
- HASKINS, C. H. *The Galvanometer and its Uses.* A Manual for Electricians and Students. Fourth Edition, revised. 12mo, morocco. \$1.50.
Transformers: Their Theory, Construction, and Application Simplified. Illustrated. 12mo, cloth. \$1.25.
- HAWKINS, C. C., and WALLIS, F. *The Dynamo: Its Theory, Design, and Manufacture.* 190 Illustrations. 8vo, cloth. \$3.00.
- HEAVISIDE, O. *Electromagnetic Theory.* 8vo, cloth. 2 vols. Each, \$5.00.
- HOBBS, W. R. P. *The Arithmetic of Electrical Measurements.* With numerous examples, fully worked. Ninth Edition. 12mo, cloth. 50 cents.
- HOPKINS, N. M. *Experimental Electrochemistry, Theoretically and Practically Treated.* Profusely illustrated with 130 new drawings, diagrams, and photographs, accompanied by a Bibliography. 8vo, cloth. Illustrated. 284 pages. Net, \$3.00.

- HOUSTON, E. J., Prof.** A Dictionary of Electrical Words, Terms, and Phrases. Fourth Edition, rewritten and greatly enlarged. 570 Illustrations. Large. 8vo, cloth. \$7.00.
- HUTCHINSON, R. W., Jr.** Long-Distance Electric Power Transmission: Being a Treatise on the Hydro-Electric Generation of Energy; Its Transformation, Transmission, and Distribution. 12mo, cloth, about 350 pp. Illustrated. In Press.
- INCANDESCENT ELECTRIC LIGHTING.** A Practical Description of the Edison System, by H. Latimer. To which is added: The Design and Operation of Incandescent Stations, by C. J. Field; A Description of the Edison Electrolyte Meter, by A. E. Kennelly; and a Paper on the Maximum Efficiency of Incandescent Lamps, by T. W. Howell. Illustrated. 16mo cloth. (No. 57 Van Nostrand's Science Series.) 50 cents.
- INDUCTION COILS: How Made and How Used.** Third Edition. 16mo, cloth. (No. 53 Van Nostrand's Science Series.) 50 cents.
- JEHL, FRANCIS, Member A.I.E.E.** The Manufacture of Carbons for Electric Lighting and other purposes. Illustrated with numerous Diagrams, Tables, and Folding Plates. Illustrated. 8vo, cloth. \$4.00.
- JONES, HARRY C.** Outlines of Electrochemistry. 8vo, cloth. Illustrated. \$1.50.
- KAPP, GIBBERT, C. E.** Electric Transmission of Energy and its Transformation, Subdivision, and Distribution. A Practical Handbook. Fourth Edition, thoroughly revised. 12mo, cloth. \$3.50.
- Alternate-Current Machinery. 190 pp. Illustrated. (No. 96 Van Nostrand's Science Series.) 50 cents.
- Dynamos, Alternators, and Transformers. Illustrated. 8vo, cloth. \$4.00.
- KELSEY, W. R.** Continuous-Current Dynamos and Motors, and their Control; being a series of articles reprinted from the "Practical Engineer," and completed by W. R. Kelsey, B.Sc. With Tables, Figures, and Diagrams. 8vo, cloth. Illustrated. \$2.50.
- KEMPE, H. R.** The Electrical Engineer's Pocket-Book: Modern Rules, Formulæ, Tables, and Data. Second Edition, with additions. 32mo, leather. \$1.75.
- A Handbook of Electrical Testing. Fifth Edition. 200 Illustrations. 8vo, cloth. \$6.00.
- KENNEDY, R.** Modern Engines and Power Generators. 4to, cloth. Illustrated. 5 vols. Each, \$3.50.
- Electrical Installations of Electric Light, Power, and Traction Machinery. 5 vols. 8vo, cloth. Illustrated. Each, \$3.50.
- KENNELLY, A. E.** Theoretical Elements of Electro-Dynamic Machinery. Vol. I. Illustrated. 8vo, cloth. \$1.50.
- KILGOUR, M. H., SWAN, H., and BIGGS, C. H. W.** Electrical Distribution: Its Theory and Practice. Illustrated. 8vo, cloth. \$4.00.

- LIVERMORE, V. P., and WILLIAMS, J.** *How to Become a Competent Motorman:* being a practical treatise on the proper method of operating a street-railway motor-car; also giving details how to overcome certain defects. 16mo, cloth. Illustrated. \$1.00.
- LOCKWOOD, T. D.** *Electricity, Magnetism, and Electro-Telegraphy.* A Practical Guide and Handbook of General Information for Electrical Students, Operators, and Inspectors. Fourth Edition. Illustrated. 8vo, cloth. \$2.50.
- LORING, A. E.** *A Handbook of the Electro-Magnetic Telegraph.* Fourth Edition, revised. 16mo, cloth. (No. 39 Van Nostrand's Science Series.) 50 cents.
- LUPTON, A. PARR, G. D. A., and PERKIN, H.** *Electricity Applied to Mining.* With Tables, Diagrams, and Folding Plates. 8vo, cloth, 280 pp. Illustrated. Net, \$3.50.
- MAILLOUX, C. O.** *Electric Traction Machinery.* 8vo, cloth. In Press.
- MANSFIELD, A. N.** *Electromagnets: Their Design and Construction.* (Van Nostrand's Science Series. No. 64.) 50 cents.
- MAVER, WM., Jr.** *American Telegraphy and Encyclopedia of the Telegraph Systems, Apparatus, Operations.* 450 Illustrations. Fifth Edition, revised. 8vo, cloth. \$5.00.
- NIPHER, FRANCIS E., A.M.** *Theory of Magnetic Measurements.* With an Appendix on the Method of Least Squares. 12mo, cloth. \$1.00.
- NOLL, AUGUSTUS.** *How to Wire Buildings.* A Manual of the Art of Interior Wiring. New Edition. In Press. 8vo, cloth. Illustrated.
- OHM, G. S., Dr.** *The Galvanic Circuit Investigated Mathematically.* Berlin, 1827. Translated by William Francis. With Preface and Notes by the Editor, Thos. D. Lockwood. 12mo, cloth. (No. 102 Van Nostrand's Science Series.) 50 cents.
- LOUDIN, MAURICE, A. M. S.** *Standard Polyphase Apparatus and Systems.* Illustrated, with many Photo-reproductions, Diagrams, and Tables. Fourth Edition, revised. 8vo, cloth. \$3.00.
- PALAZ, A.** *Treatise on Industrial Photometry.* Specially applied to Electric Lighting. Translated from the French by G. W. Patterson, Jr., Assistant Professor of Physics in the University of Michigan, and M. R. Patterson, B.A. Second Edition. Fully Illustrated. 8vo, cloth. \$4.00.
- PARR, G. D. A.** *Electrical Engineering Measuring Instruments, for Commercial and Laboratory Purposes.* With 370 Diagrams and Engravings. 8vo, cloth. Illustrated. Net, \$3.50.
- PARSHALL, H. F., and HOBART, H. M.** *Armature Windings of Electric Machines.* Second Edition. With 140 full-page Plates, 65 Tables, and descriptive letter-press. 4to, cloth. \$7.50.

- PERRINE, F. A. C., A.M., D.Sc.** Conductors for Electrical Distribution: Their Manufacture and Materials, the Calculation of Circuits, Pole-Line Construction, Underground Working, and other Uses. 8vo, cloth. Illustrated. Net, \$3.50.
- PLANTE, GASTON.** The Storage of Electrical Energy, and Researches in the Effects created by Currents combining Quantity with High Tension. Translated from the French by Paul B. Elwell. 89 Illustrations. 8vo. \$4.00.
- POPE, F. L.** Modern Practice of the Electric Telegraph. A Handbook for Electricians and Operators. An entirely new work, revised and enlarged, and brought up to date throughout. Illustrations. 8vo, cloth. \$1.50.
- RAPHAEL, F. C.** Localization of Faults in Electric-Light Mains. Second Edition, revised. 8vo, cloth. Illustrated. Net, \$3.00.
- RAYMOND, E. B.** Alternating-Current Engineering, Practically Treated. With many Figures and Diagrams. Second Edition, revised. 8vo, cloth. Illustrated. Net, \$2.50.
- SALOMONS, Sir DAVID, M.A.** Electric-Light Installations. A Practical Handbook. Seventh Edition, revised and enlarged. Vol. I.: Management of Accumulators. Illustrated. 12mo, cloth. Reprinting. Vol. II.: Apparatus Illustrated. 12mo, cloth. \$2.25. Vol. III.: Application. Illustrated. 12mo, cloth. \$1.50.
- SHELLEN, H., Dr.** Magneto-Electric and Dynamo-Electric Machines. Their Construction and Practical Application to Electric Lighting and the Transmission of Power. Translated from the Third German Edition by N. S. Keith and Percy Neymann, Ph.D. With very large Additions and Notes relating to American Machines, by N. S. Keith. Vol. I. With 353 Illustrations. Third Edition. \$5.00.
- SEVER, G. F.** Electrical Engineering Experiments and Tests on Direct-Current Machinery. With Diagrams and Figures. 8vo, pamphlet. Illustrated. Net, \$1.00.
- SEVER, G. F., and TOWNSEND, F.** Laboratory and Factory Tests in Electrical Engineering. 8vo, cloth. Illustrated. 225 pp. Net, \$2.50.
- SEWALL, C. H.** Wireless Telegraphy. With Diagrams and Figures. Second Edition, corrected. 8vo, cloth. Illustrated. Net, \$2.00.
Lessons in Telegraphy. 12mo, cloth. Illustrated. Net, \$1.00. In Press.
- SEWELL, T.** Elements of Electrical Engineering. Second Edition, revised. 8vo, cloth. Illustrated. 432 pp. Net. \$3.00.
- SHELDON, S., Ph.D., and MASON, H., B.S.** Dynamo-Electric Machinery: Its Construction, Design, and Operation. Direct-Current Machines. Fifth Edition, revised. Illustrated. 8vo, cloth. Net, \$2.50.
Alternating-Current Machines: being the second volume of the author's "Dynamo-Electric Machinery: its Construction, Design, and Operation." With many Diagrams and Figures. (Binding uniform with Volume I.) Fourth Edition. Illustrated. 8vo, cloth. Net, \$2.50.

- SLOANE, T. O'CONNOR, Prof. **Standard Electrical Dictionary.** 300 Illustrations. 8vo, cloth. \$3.00.
- SNELL, ALBION T. **Electric Motive Power.** The Transmission and Distribution of Electric Power by Continuous and Alternating Currents. With a Section on the Applications of Electricity to Mining Work. Illustrated. 8vo, cloth. \$4.00.
- SODDY, F. **Radio-activity: an Elementary Treatise from the Standpoint of the Disintegration Theory.** Fully Illustrated, and with a complete table of Contents and Extended Index. 8vo, cloth. Illustrated. Net, \$3.00.
- SWINBURNE, JAS., and WORDINGHAM, C. H. **The Measurement of Electric Currents.** Electrical Measuring Instruments. Meters for Electrical Energy. Edited, with Preface, by T. Commerford Martin. Folding Plate and numerous Illustrations. 16mo, cloth. 50 cents.
- SWOOPE, C. WALTON. **Practical Lessons in Electricity: Principles, Experiments, and Arithmetical Problems.** An Elementary Text-book. With numerous Tables, Formulæ, and two large Instruction Plates. Sixth Edition. Illustrated. 8vo, cloth. Net, \$2.00.
- THOM, C., and JONES, W. H. **Telegraphic Connections, embracing recent methods in Quadruplex Telegraphy.** 20 Colored Plates. 8vo, cloth. \$1.50.
- THOMPSON, S. P., Prof. **Dynamo-Electric Machinery.** With an Introduction and Notes by Frank L. Pope and H. R. Butler. Fully Illustrated. (No. 66 Van Nostrand's Science Series.) 50 cents.
- Recent Progress in Dynamo-Electric Machines. Being a Supplement to "Dynamo-Electric Machinery." Illustrated. 12mo, cloth. (No. 75 Van Nostrand's Science Series.) 50 cents.
- Dynamo-Electric Machinery. Vol. I. 8vo, cloth, 996 pp. 573 Illustrations. 4 Colored and 32 Folding Plates. \$7.50.
- TREVERT, E. **How to Build Dynamo-Electric Machinery.** Embracing the Theory, Designing, and Construction of Dynamos and Motors. With Appendices on Field-Magnet and Armature Winding, Management of Dynamos and Motors, and useful Tables of Wire Gauges. Illustrated. 8vo, cloth. \$2.50.
- TUNZELMANN, G. W. de. **Electricity in Modern Life.** Illustrated. 12mo, cloth. \$1.25.
- UNDERHILL, C. R. **The Electromagnet: Being a new and revised edition of "The Electromagnet,"** by Townsend Walcott, A. E. Kennelly, and Richard Varley. With Tables and Numerous Figures and Diagrams. 12mo, cloth. Illustrated. \$1.50.

- URQUHART, J. W.** **Dynamo Construction.** A Practical Handbook for the use of Engineer Constructors and Electricians in Charge. Illustrated. 12mo, cloth. \$3.00.
- Electric Ship-Lighting.** A Handbook on the Practical Fitting and Running of Ship's Electrical Plant, for the use of Ship Owners and Builders, Marine Electricians, and Sea-going Engineers in Charge. 88 Illustrations. 12mo, cloth. \$3.00.
- Electric-Light Fitting.** A Handbook for Working Electrical Engineers, embodying Practical Notes on Installation Management. Second Edition, with additional chapters. With numerous Illustrations. 12mo, cloth. \$2.00.
- Electroplating.** Fourth Edition. 12mo, cloth. \$2.00.
- Electrotyping.** 12mo, cloth. \$2.00.
- WADE, E. J.** **Secondary Batteries: Their Theory, Construction, and Use.** With innumerable Diagrams and Figures. 8vo, cloth. Illustrated. Net, \$4.00.
- WALKER, FREDERICK.** **Practical Dynamo-Building for Amateurs.** How to Wind for any Output. Illustrated. 16mo, cloth. (No. 98 Van Nostrand's Science Series.) 50 cents.
- WALLING, B. T., Lieut.-Com. U.S.N., and MARTIN, JULIUS.** **Electrical Installations of the United States Navy.** With many Diagrams and Engravings. In press.
- WATT.** **Electroplating and Refining of Metals.** 8vo, cloth. Illustrated. Net, \$4.50.
- Electro-Metallurgy.** Eleventh Edition. 12mo, cloth. \$1.00.
- WEBB, H. L.** **A Practical Guide to the Testing of Insulated Wires and Cables.** Illustrated. 12mo, cloth. \$1.00.
- WEEKS, R. W.** **The Design of Alternate-Current Transformer.** New Edition. In press.
- WEYMOUTH, F. MARTEN.** **Drum Armatures and Commutators.** (Theory and Practice.) A complete treatise on the theory and construction of drum-winding, and of commutators for closed-coil armatures, together with a full résumé of some of the principal points involved in their design; and an exposition of armature reactions and sparking. Illustrated. 8vo, cloth. \$3.00.
- WILKINSON, H. D.** **Submarine Cable-Laying, Repairing, and Testing.** 8vo, cloth. Reprinting.

^v tees net

BOOK IS DUE ON THE LAST DATE
STAMPED BELOW

. INITIAL FINE OF 25 CENTS

WILL BE ASSESSED FOR FAILURE TO RETURN
THIS BOOK ON THE DATE DUE. THE PENALTY
WILL INCREASE TO 50 CENTS ON THE FOURTH
DAY AND TO \$1.00 ON THE SEVENTH DAY
OVERDUE.

OCT 10 1940 M

OCT 10 1940 M.

TK6550
RB

196522

Ruhmer

